



Return to Main Menu



Return to List of Standards



Return to History of Standards



American Water Works Association

ANSI/AWWA D110-13 (R18)
(Revision of ANSI/AWWA D110-04)
Reaffirmed without revisions

AWWA Standard

Wire- and Strand-Wound, Circular, Prestressed Concrete Water Tanks

Effective date: Aug. 1, 2018.
First edition approved by AWWA Board of Directors June 22, 1986.
This edition approved Mar. 30, 2018.
Approved by American National Standards Institute May 2, 2018.



AWWA Standards have been used with permission and are copyrighted to the American Water Works Association. All rights reserved.

AWWA Standard

This document is an American Water Works Association (AWWA) standard. It is not a specification. AWWA standards describe minimum requirements and do not contain all of the engineering and administrative information normally contained in specifications. The AWWA standards usually contain options that must be evaluated by the user of the standard. Until each optional feature is specified by the user, the product or service is not fully defined. AWWA publication of a standard does not constitute endorsement of any product or product type, nor does AWWA test, certify, or approve any product. The use of AWWA standards is entirely voluntary. This standard does not supersede or take precedence over or displace any applicable law, regulation, or codes of any governmental authority. AWWA standards are intended to represent a consensus of the water supply industry that the product described will provide satisfactory service. When AWWA revises or withdraws this standard, an official notice of action will be placed on the first page of the Official Notice section of *Journal - American Water Works Association*. The action becomes effective on the first day of the month following the month of *Journal - American Water Works Association* publication of the official notice.

American National Standard

An American National Standard implies a consensus of those substantially concerned with its scope and provisions. An American National Standard is intended as a guide to aid the manufacturer, the consumer, and the general public. The existence of an American National Standard does not in any respect preclude anyone, whether that person has approved the standard or not, from manufacturing, marketing, purchasing, or using products, processes, or procedures not conforming to the standard. American National Standards are subject to periodic review, and users are cautioned to obtain the latest editions. Producers of goods made in conformity with an American National Standard are encouraged to state on their own responsibility in advertising and promotional materials or on tags or labels that the goods are produced in conformity with particular American National Standards.

CAUTION NOTICE: The American National Standards Institute (ANSI) approval date on the front cover of this standard indicates completion of the ANSI approval process. This American National Standard may be revised or withdrawn at any time. ANSI procedures require that action be taken to reaffirm, revise, or withdraw this standard no later than five years from the date of ANSI approval. Purchasers of American National Standards may receive current information on all standards by calling or writing the American National Standards Institute, 25 West 43rd Street, Fourth Floor, New York, NY 10036; (212) 642-4900, or emailing info@ansi.org.

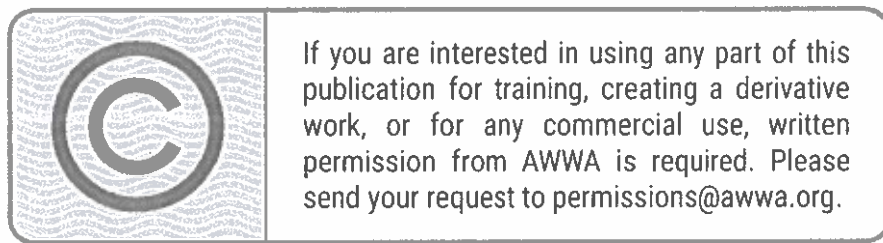

ISBN-13, print: 978-1-58321-980-5

eISBN-13, electronic: 978-1-61300-2575

All rights reserved. No part of this publication may be reproduced or transmitted in any form or by any means, electronic or mechanical, including scanning, recording, or any information or retrieval system. Reproduction and commercial use of this material is prohibited, except with written permission from the publisher.

Copyright © 2013 by American Water Works Association
Printed in USA

Committee Personnel

The AWWA Standards Committee on Concrete Water Tanks, Wire-Wound Prestressed, which reviewed and approved this standard, had the following personnel for this revision:

Dominic J. Kelly, *Chair*
Andrew Minogue, *Secretary*

User Members

P.H. Bilodeau, Maine Water Company, Saco, Maine
W.J. Horst, Montgomery County Environmental Services, Dayton, Ohio
J.G. Obrist, City of Lincoln, Lincoln, Neb.
M.L. Washington, Tacoma Water, Tacoma, Wash.

General Interest Members

J.W. Birkhoff, Birkhoff, Hendricks & Carter LLP, Dallas, Texas
M.M. Coleman,[†] Standards Council Liaison, Wade Trim Associates Inc., Detroit, Mich.
D.J. Kelly, Simpson Gumpertz & Heger Inc., Waltham, Mass.
F.S. Kurtz,[‡] Standards Engineer Liaison, AWWA, Denver, Colo.
M.W. Morin, Hazen and Sawyer, Manchester N.H.
B.J. Phelps, CH2M, Vancouver, Wash.
W.B. Powers, Brown and Caldwell, Andover, Mass.
L.G. Soohoo, Stantec, Walnut Creek, Calif.
J.B. Walfish, James B. Walfish Structural Engineer, Honolulu, Hawaii
S. Wong, Kleinfelder, San Diego, Calif.
M.S. Zarghamee,^{*} Simpson Gumpertz & Heger Inc., Waltham, Mass.

Producer Members

T.W. Bloomer,^{*} DN Tanks, El Cajon, Calif.
W. Cooksey,^{*} Preload, Louisville, Ky.
S.M. Crawford, The Crom Corporation, Gainesville, Fla.
T.B. Mincey,^{*} The Crom Corporation, Chattanooga, Tenn.

A. Minogue, DN Tanks, Grand Prairie, Texas
R.G. Moore, Precon Corporation, Newberry, Fla.
A.E. Tripp Jr., Preload, Hauppauge, N.Y.
M.J. Vineyard,* Precon Corporation, Newberry, Fla.

*Alternate
† Liaison, nonvoting

Contents

All AWWA standards follow the general format indicated subsequently. Some variations from this format may be found in a particular standard.

| SEC. | PAGE | SEC. | PAGE |
|--------------------|------|---|--|
| Foreword | | | |
| I | vii | 2.8 | Concrete and Shotcrete Coatings..... 13 |
| I.A | vii | 2.9 | Sealants and Joint Fillers 13 |
| I.B | vii | 2.10 | Epoxy Bonding Agent 15 |
| I.C | viii | 2.11 | Epoxy Mortar and Grout 15 |
| II | ix | 2.12 | Form Coatings 15 |
| II.A | ix | 3 Design | |
| II.B | ix | 3.1 | Notation..... 15 |
| III | ix | 3.2 | Design Method 16 |
| III.A | x | 3.3 | Design Loads 17 |
| III.B | xi | 3.4 | Allowable Stresses..... 19 |
| III.C | xii | 3.5 | Wall Design 22 |
| IV | xii | 3.6 | Dome-Roof Design 25 |
| V | xiv | 3.7 | Other Roof Designs 30 |
| | | 3.8 | Floor Design 30 |
| | | 3.9 | Footing Design 33 |
| | | 3.10 | Columns 34 |
| | | 3.11 | Tank Appurtenances 34 |
| Standard | | | |
| 1 General | | 4 Provisions for Earthquake-Induced Forces | |
| 1.1 | 1 | 4.1 | Introduction..... 38 |
| 1.2 | 2 | 4.2 | Seismic Joint Types 43 |
| 1.3 | 4 | 4.3 | Seismic Design Loads..... 44 |
| 2 Materials | | 4.4 | Vertical and Horizontal Forces 54 |
| 2.1 | 8 | 4.5 | Other Effects..... 55 |
| 2.2 | 8 | 4.6 | Maximum Allowable Stresses and Reinforcement Requirements 57 |
| 2.3 | 9 | 4.7 | Maximum Allowable Coefficient of Friction 58 |
| 2.4 | 9 | 4.8 | Additional Requirements..... 59 |
| 2.5 | 10 | | |
| 2.6 | 12 | | |
| 2.7 | 13 | | |

| SEC. | PAGE | SEC. | PAGE |
|--|------|---|------|
| 4.9 | 59 | Appendix | |
| 4.10 | 60 | Alternative Method of Analysis Based on | |
| 4.11 | 61 | UBC 1997..... | 89 |
| 5 | | Figures | |
| Construction Procedures | | 1 Example Diaphragm Sheet..... | 10 |
| 5.1 Scope | 61 | 2 Joints Between Wall and Dome | |
| 5.2 Concrete..... | 61 | Edge Ring..... | 26 |
| 5.3 Shotcrete | 66 | 3 Typical Floor-Slab Construction | |
| 5.4 Forming..... | 71 | Joint | 31 |
| 5.5 Nonprestressed-Steel Reinforcement | | 4 Types of Joints Used Between the Wall | |
| and Vertical Tendons..... | 72 | and Its Foundation | 44 |
| 5.6 Prestressing | 72 | 5 Curve for Obtaining Factor C_w for the | |
| 5.7 Wall Tolerances..... | 76 | Ratio r/H | 47 |
| 5.8 Restraint Cables | 76 | 6 Curve for Obtaining Factor K_p for the | |
| 5.9 Waterstops..... | 76 | Ratio r/H | 49 |
| 5.10 Elastomeric Bearing Pads | 76 | 7 Curves for Obtaining Factor W_c/W_f and | |
| 5.11 Sponge Fillers..... | 77 | W_c/W_f for the Ratio r/H | 50 |
| 5.12 Watertightness..... | 77 | 8 Curves for Obtaining Factor X_c/H and | |
| 5.13 Repairs | 78 | X_c/H for the Ratio r/H | 51 |
| 5.14 Tank Backfill..... | 79 | 9 Net Effective Base-Pad Width After | |
| 5.15 Cleanup | 80 | Deformation..... | 58 |
| 5.16 Electrical Grounding..... | 80 | 10 Diaphragm Patching Detail for | |
| 5.17 Lightning Protection | 80 | Type IV Tank Core Wall..... | 72 |
| 6 | | A.1 Adjusted UBC 1997 Design | |
| Inspection Procedures | | Response Spectrum | 90 |
| 6.1 Scope | 80 | Tables | |
| 6.2 Field Observation During | | 1 Allowable Stresses in Concrete and | |
| Construction..... | 80 | Shotcrete | 19 |
| 6.3 Inspection After Structure Is | | 1M Metric Conversion..... | 20 |
| Constructed | 83 | 2 Importance Factor..... | 40 |
| 6.4 Routine Inspections | 84 | 3 Structural Response Coefficient for | |
| 6.5 Safety | 87 | Type of Tank..... | 41 |
| | | 4 Soil Site Class Definitions | 47 |

Foreword

This foreword is for information only and is not a part of ANSI/AWWA D110.

I. Introduction.

I.A. *Background.* The New England Water Works Association (NEWWA) established a committee in 1958 to prepare a standard specification for the design and construction of prestressed concrete water-storage tanks. The committee submitted a suggested specification to NEWWA in October 1962 as a guide to those in the water industry who wished to consider the use of these tanks.

American Concrete Institute (ACI) Committee 344 concluded eight years of committee work with a report titled "Design and Construction of Circular Prestressed Concrete Structures," published in the *ACI Journal* September 1970. This report referred primarily to wire-wound tanks.

I.B. *History.* In the December 1972 issue of *Journal AWWA*, the applicability of the ACI report to water containment structures was discussed in four articles. As a result of these articles and continued discussion on the subject, a standards committee was authorized by the American Water Works Association (AWWA) to develop an AWWA standard for circular, prestressed concrete water tanks.

An AWWA standards committee on circular, prestressed concrete water tanks was appointed and held its first meeting June 19, 1974. During its first two years, the committee studied the various types of prestressed tanks then in service or under construction and determined that most were of the wire-wound type. Therefore, the committee in 1976 was directed to limit its scope to the wire- and strand-wound prestressed tank wall design. The first edition of this standard incorporated the work of ACI Committee 344 and contained additional requirements and recommendations, specifically for potable and process water, and for wastewater containment structures. The new standard, ANSI/AWWA D110-86, Standard for Wire-Wound Circular Prestressed-Concrete Water Tanks, was approved by the AWWA Board of Directors on June 22, 1986, and had an effective date of June 1, 1987. The standard has been in use since approval by the American National Standards Institute (ANSI) on Mar. 3, 1987.

The first revision of this standard was initiated by the AWWA Standards Committee during 1990 according to AWWA Standards Council policy. The revised standard ANSI/AWWA D110-95 was approved on June 22, 1995, by the AWWA Board of

* American National Standards Institute, 25 West 43rd Street, Fourth Floor, New York, NY 10036.

Directors. The next edition of the standard, ANSI/AWWA D110-04, was approved by the AWWA Board of Directors on Jan. 18, 2004. This edition, ANSI/AWWA D110-13, was approved by the AWWA Board of Directors on Jan. 20, 2013.

I.C. *Acceptance.* In May 1985, the US Environmental Protection Agency (USEPA) entered into a cooperative agreement with a consortium led by NSF International (NSF) to develop voluntary third-party consensus standards and a certification program for direct and indirect drinking water additives. Other members of the original consortium included the Water Research Foundation (formerly AwwaRF) and the Conference of State Health and Environmental Managers (COSHEM). The American Water Works Association (AWWA) and the Association of State Drinking Water Administrators (ASDWA) joined later.

In the United States, authority to regulate products for use in, or in contact with, drinking water rests with individual states.^{*} Local agencies may choose to impose requirements more stringent than those required by the state. To evaluate the health effects of products and drinking water additives from such products, state and local agencies may use various references, including

1. An advisory program formerly administered by USEPA, Office of Drinking Water, discontinued on Apr. 7, 1990.
2. Specific policies of the state or local agency.
3. Two standards developed under the direction of NSF, NSF[†]/ANSI[‡] 60, Drinking Water Treatment Chemicals—Health Effects, and NSF/ANSI 61, Drinking Water System Components—Health Effects.
4. Other references, including AWWA standards, *Food Chemicals Codex*, *Water Chemicals Codex*,[§] and other standards considered appropriate by the state or local agency.

Various certification organizations may be involved in certifying products in accordance with NSF/ANSI 61. Individual states or local agencies have authority to accept or accredit certification organizations within their jurisdiction. Accreditation of certification organizations may vary from jurisdiction to jurisdiction.

Annex A, “Toxicology Review and Evaluation Procedures,” to NSF/ANSI 61 does not stipulate a maximum allowable level (MAL) of a contaminant for substances not

* Persons outside the United States should contact the appropriate authority having jurisdiction.

† NSF International, 789 N. Dixboro Road, Ann Arbor, MI 48105.

‡ American National Standards Institute, 25 West 43rd Street, Fourth Floor, New York, NY 10036.

§ Both publications available from National Academy of Sciences, 500 Fifth Street, NW, Washington, DC 20418.

regulated by a USEPA final maximum contaminant level (MCL). The MALs of an unspecified list of “unregulated contaminants” are based on toxicity testing guidelines (noncarcinogens) and risk characterization methodology (carcinogens). Use of Annex A procedures may not always be identical, depending on the certifier.

ANSI/AWWA D110 does not address additives requirements. Users of this standard should consult the appropriate state or local agency having jurisdiction in order to

1. Determine additives requirements, including applicable standards.
2. Determine the status of certifications by parties offering to certify products for contact with, or treatment of, drinking water.
3. Determine current information on product certification.

II. Special Issues.

II.A. Intent. This standard reflects a committee consensus of industry practice concerning the design, detailing, and construction of circular, prestressed concrete water tanks of several types, with or without vertical prestressing of the tank core wall. The horizontal prestressed reinforcement of the tank wall is accomplished by the application of helically wound high-tensile-stress wire or strand under controlled tension on the surface of the core wall, protected by shotcrete cover coats.

Recommended criteria and guidelines are presented to assist engineers in the design, construction, and inspection of tanks with shotcrete, cast-in-place concrete, or precast circular concrete core walls, with or without internal steel diaphragms, based on the successful application of these concepts in practice and the detailed experience of committee members. Engineering principles are tied to existing codes where applicable.

The intent is also to assist the designer and constructor by sharing information on the unique aspects in analysis and construction that are encountered in these types of structures.

II.B. Limitations. Because of the wide range of site-specific environments, foundation conditions, loadings, and construction conditions throughout North America, this standard should not be expected to apply universally nor to produce a cost-effective and completely maintenance-free structure in every situation. In adapting this standard to obtain the structure’s expected service life for the actual conditions that are anticipated, the purchaser and the designer of the tank are advised to carefully study all factors affecting the structure during its anticipated service life.

III. Use of This Standard. It is the responsibility of the user of an AWWA standard to determine that the products described in that standard are suitable for use in the particular application being considered.

III.A. *Industry Practice and Assumptions.* It is not the purpose of this standard to either define or recommend contractual relationships or to stipulate contractual obligations, both of which are the responsibility of the purchaser. Generally, purchasers may solicit competitive bids for wire- and strand-wound circular prestressed concrete tanks by one of two methods.

According to the first method, a design professional is retained by the purchaser to prepare construction drawings, specifications, and other contract documents. Competitive bids are then solicited from constructors and suppliers for construction of the tank. In this standard, these are referred to as purchaser-furnished designs.

According to the second method, the purchaser prepares performance specifications that require bidding constructors to prepare project designs and specifications and to construct the tank according to the design. In this standard, these are referred to as design-construct projects.

While the division of information that must be covered in the purchaser's specifications for execution of each method of contracting differs substantially, depending on who is responsible for the tank design, the information that must be supplied by the purchaser to successfully apply this standard is essentially the same.

ANSI/AWWA D110 does not address matters related to site selection and property acquisition. It is assumed that the purchaser will have conducted sufficient background work in the form of water system studies, predesign surveys, subsurface investigations, preliminary design work, etc., to establish the desired tank site, volume, operating water depth, and elevations. Further, it is assumed that the purchaser will have acquired the property, easements, and rights-of-way necessary for construction of the facility, including site access, the tank structure, and associated water pipelines connecting the tank to the water system and drainage, if required. Specifically, it has been assumed that the purchaser will arrange for or provide the following as necessary or appropriate:

1. The site on which the tank is to be built, with adequate space to permit the constructor to erect the structure using customary methods.
2. A predesign site survey and preparation of a site plan showing existing topography, property lines, approximate tank centerline location, setback, encumbrances, details of special construction features, and extent of final site grading.
3. A site geotechnical survey and foundation report, including logs of borings and test pits, soil densities, and other pertinent soil and geological information; construction criteria for any backfill that may be necessary at a particular site; and foundation design criteria prepared by a registered design professional specializing in

soil mechanics, including allowable bearing loads, anticipated total and differential settlements, and the seismic soil profile type.

4. Structural loading conditions, including, but not limited to, snow, wind, seismic, hydrostatic uplift, and other live loads depending on the tank's intended use; the amount of earth cover over the tank, if any; the height of backfill against the tank wall, if any; and any other special loading conditions that are anticipated or special criteria on which the tank design is to be based. If, for example, the tank is located in a high-intensity earthquake area and must continue to serve without damage following an earthquake, the purchaser may specify an importance factor for earthquake design as described in Table 2 or provide design values for the peak horizontal ground acceleration and for the spectrum velocity. In cases for which the design must consider static and dynamic earth pressures resulting from seismic shaking, the purchaser shall provide the required geotechnical data to evaluate these additional loading conditions in the tank design along with the soil site class as shown in Table 4.

5. Requirements for subdrainage and overflow collection systems.

6. The use of electric power and water service, if available, at the site.

III.B. *Purchaser Options and Alternatives.* The following information should be provided by the purchaser:

1. Whether compliance with NSF/ANSI 61, Drinking Water System Components—Health Effects, is required.

The items that follow are either required information or alternative options in the standard that should be considered and covered by the purchaser, unless the purchaser intends that the choice for a particular option be left to the tank designer's discretion.

1. The standard to be used—that is, ANSI/AWWA D110, Standard for Wire- and Strand-Wound, Circular, Prestressed Concrete Water Tanks, of latest revision.

2. The required capacity of the tank, including side water depth or diameter.

3. Requirements for subdrainage and overflow collection systems.

4. Seismic information required.

a. The Occupancy Category as indicated in ASCE 7-05.

b. Importance factor (Table 2).

c. Structural response coefficient for type of tank (Table 3).

d. Soil site class definitions (Table 4).

5. Information on access to the site for the constructor's equipment and for supply of construction materials.

6. Availability and characteristics of electric power and source of water for construction.

7. The type of roof and type or types of tank wall. Basic wall types (Sec. 1.1.1). Roof structures may be shotcrete or concrete domes (Sec. 3.6), nonprestressed concrete flat slabs supported by columns (Sec. 3.7), or other types of roofs selected by the purchaser. Preference for wet mix or dry mix for the tank wall or shotcrete cover coats (Sec. 2.2.2.2).
8. Details of other federal, state or provincial, and local requirements (Sec. 2.1).
9. Subsurface investigation and report (Sec. 3.8.4).
10. Tank appurtenances required (Sec. 3.11).
 - a. Specifications for any additional accessories to be provided.
 - b. Requirements for a water-level gauge or pressure sensor, or other level monitoring device (Sec. 3.11.2.4).
 - c. Size, material, and location of vents, access hatches, ladders, stairs, and manways; and locking and safety devices required (Sec. 3.11.3).
 - d. Whether or not a removable silt stop is required and whether baffles are provided for circulation (Sec. 3.11.7).
11. Size, material, location, details, cover depths, and limits of responsibility for all other pipe connections (Sec. 3.11.1).
12. Maximum filling (overflow) and emptying rates required (Sec. 3.11.2).
13. Size, material, arrangement, and location for the overflow pipe (Sec. 3.11.2).
14. Special exterior wall coatings or architectural treatment, if any (Sec. 3.11.6).
15. Seismic joint types (Sec. 4.2).
16. Maximum allowable stresses and reinforcement requirements (Sec. 4.6).
17. Maximum allowable coefficient of friction requirements (Sec. 4.7).
18. Foundation design requirements (Sec. 4.9).
19. The required elevation of the overflow weir and freeboard requirements (Sec. 4.10).
20. Design for seismic effects on backfill requirements (Sec. 4.11).
21. Finish grade relative to the tank foundation. (Whether or not the wall is to be completely exposed, partially buried, or completely buried.) (Sec. 4.11, Sec. 5.14)
22. Restraint cable requirements (Sec. 5.8).

III.C. *Modification to Standard.* Any modification of the provisions, definitions, or terminology in this standard must be provided by the purchaser.

IV. Major Revisions. This edition of the standard has been edited throughout and includes revisions to stated definitions and terms to achieve a higher degree of consistency among the various AWWA standards. The technical revisions to this

standard reflect current thinking and construction practices. These include the following:

1. A global change of references from ACI 318, Building Code Requirements for Structural Concrete, to ACI 350, Code Requirements for Environmental Engineering Concrete Structures. ACI 350 is the ACI code that deals directly with liquid-containing structures and is applicable to ANSI/AWWA D110 structures.
2. The addition of specific strength requirements for concrete slab.
3. References to “portland cement” have been changed to “cementitious material”; this change is intended to include supplemental cementitious materials such as fly ash, ground granulated blast furnace slag, and microsilica.
4. A global change of reference from “seismic cables” to “restraint cables” to reflect their use for other lateral loading conditions, such as differential backfill.
5. The elimination of Table 1 of ANSI/AWWA D110-04, Sec. 2.6, providing PVC waterstop test methods and limits, as this is directly covered by reference to Corps of Engineers CRD-C572.
6. The addition of urethane elastomer as a type of sealant and joint filler.
7. An update to the minimum design wind and seismic loads from the most recent versions of the IBC and ASCE 7.
8. The addition of construction loads as a roof design load.
9. The addition of metric equivalents to equations.
10. A clarification that the design calculations are performed by a registered design professional who is responsible for the design.
11. A reduction of the minimum roof rise-to-span ratio from 1:12 to 1:16 as a result of successful industry experience with lower-rise domes.
12. An update of the dome buckling equation to address changes in load factors.
13. The addition of requirements for compaction of cohesionless base material, such as gravel, under the floor.
14. A clarification of methods for concrete pipe encasement of under-floor pipe.
15. The addition of ultrasonic level sensors.
16. Guidance on conditions in which an interior ladder and/or wall accessway would be appropriate.
17. Incorporation of the new seismic design approach based on the IBC, ASCE 7-05 code standards, and current seismic technological advances resulting from the NEHRP research study.
18. The inclusion of urethane as a suitable material for crack injection.

19. Additional information on tank inspection, including inspector qualifications and suggested areas of inspection.

V. Comments. If you have any comments or questions about this standard, please call AWWA Engineering and Technical Services at 303.794.7711, FAX at 303.795.7603, write to the department at 6666 West Quincy Avenue, Denver, CO 80235-3098, or email at standards@awwa.org.



American Water Works
Association

ANSI/AWWA D110-13
(Revision of ANSI/AWWA D110-04)

AWWA Standard

Wire- and Strand-Wound, Circular, Prestressed Concrete Water Tanks

SECTION 1: GENERAL

Sec. 1.1 Scope

1.1.1 *Intent of standard.* The intent of this standard is to describe current recommended practice for the design, construction, inspection, and maintenance of wire- and strand-wound, circular, prestressed concrete water-containing structures with the following four types of core walls:

Type I—cast-in-place concrete with vertical prestressed reinforcement

Type II—shotcrete with a steel diaphragm

Type III—precast concrete with a steel diaphragm

Type IV—cast-in-place concrete with a steel diaphragm

1.1.2 *Items not described in standard.* This standard does not describe bonded or unbonded horizontal tendons for prestressed reinforcement of the tank wall, floor, or roof.

1.1.3 *Tank contents.* This standard applies to containment structures for use with potable water or raw water of normal temperature and pH commonly found in drinking water supplies. It is not intended for use in the design of containment structures for highly aggressive waters or high-temperature waters without special consideration being given to their effects on the structure; nor is it

intended that the standard be used for the design of structures for wastewater, bulk dry storage, chemical storage, or storage of slurries.

Sec. 1.2 Definitions

In this standard, the following definitions apply:

1.2.1 *Base and top-of-wall joints.* Connections between the base of the tank's core wall and its foundation or floor slab and between the top of the wall and roof slab or dome.

Types of wall–base joints may be generally defined as follows:

1. *Anchored flexible:* Minimum restraint of radial translation and rotation, employing restraint anchor cables between the joint components to resist tangential displacement.

2. *Unanchored and uncontained, free:* Minimal restraint of radial translation and rotation.

Types of wall–roof joints in general use may be defined as follows:

1. *Reinforced nonsliding:* Fixed for restraint of radial translation and rotation.

2. *Separated:* Minimal restraint of radial translation and rotation.

1.2.2 *Capacity.* The net volume of contents that may be removed from a tank filled to the overflow level.

1.2.3 *Core wall.* That portion of the concrete or shotcrete wall that is circumferentially prestressed.

1.2.4 *Duct.* Tubing for forming internal voids in the core wall for placement of vertical prestressed reinforcement.

1.2.5 *Membrane floor.* A thin, highly reinforced, low-moment-resistant, concrete slab-on-grade designed to be a flexible watertight floor system.

1.2.6 *Mortar and grout.* Includes the following types:

1. *Cement grout:* A mixture of cementitious material (portland cement) and potable water of pourable consistency (without segregation of constituents) used to bond and provide corrosion protection to prestressed tendons in a duct.

2. *Cement mortar:* Generally, a mixture of sand, cement, and water of specified proportions.

3. *Epoxy bonding agent:* An epoxy resin normally used in repair processes to bond fresh plastic concrete mix, cement mortar, or epoxy mortar to hardened concrete.

4. *Epoxy grout:* An epoxy-resin system used to bond and provide corrosion protection to vertical prestressed tendons in a duct.

5. *Epoxy mortar*: A mixture of epoxy resin, catalyst, and fine aggregate for repair of concrete.

6. *Nonshrink grout*: A shrinkage-compensating, expansive cement grout used for concrete repair and patching of form-tie holes.

1.2.7 *Parties*. The persons, companies, or organizations generally involved in the purchase, design, and construction of circular, prestressed concrete tanks, including

1. *Constructor*: The party that provides the work and materials for placement or installation.

2. *Design-constructor*: A firm that specializes in, designs, and constructs prestressed concrete tanks.

3. *Designer*: The registered design professional responsible for the design of the tank.

4. *Manufacturer*: The party that manufactures, fabricates, or produces materials or products.

5. *Purchaser*: The person, company, or organization that purchases any materials or work to be performed.

6. *Purchaser's engineering agent*: The registered design professional representing the purchaser in the preparation of construction documents for the tank project or representing the purchaser during its construction.

1.2.8 *Prestressed concrete*. Concrete in which internal compressive stresses of such magnitude and distribution are introduced that the tensile stresses resulting from the service loads are counteracted to the desired degree; circumferential prestress of the tank wall is introduced herein by the helical application of high-strength steel wire or strand under controlled tension and vertical prestress is provided by post-tensioned, high-strength steel bar or strand tendons.

1.2.9 *Prestressing reinforcement*. High-strength steel used to prestress the concrete or shotcrete of the tank wall or dome roof edge ring, commonly composed of either single wires, seven-wire strands, or bars.

1. *Strand*: A symmetrically arranged and helically twisted assembly, commonly of seven high-strength steel wires, used for prestressed reinforcement or as nonprestressed restraint cables.

2. *Tendon*: High-strength strand or bar, including end anchorages, used to impart vertical prestress to the tank wall.

3. *Wire*: High-strength, cold-drawn steel wire used for prestressed reinforcement.

1.2.10 *Shotcrete.* Pneumatically applied wet- or dry-mix mortar or concrete used for the core wall or as embedment and protection of the circumferential prestressed wall reinforcement, including

1. *Cover coat:* Shotcrete applied over the wire coat of the outer layer of prestressed wire or strand.

2. *Finish coat:* The final layer of cover coat, usually placed for improved appearance.

3. *Wire coat:* Initial application of shotcrete over the prestressed wire or strand.

1.2.11 *Specifications.* A statement describing the structure to be provided and containing the details of construction materials, methods, or contractor performance required in conjunction with the construction drawings and other contract documents for the structure.

1.2.12 *Standpipe.* A cylindrical structure for water storage, based at or below grade and having a wall height greater than its diameter. Standpipes are considered a special type of tank because of generally more critical loading conditions. Use of this standard in the design and construction of standpipes is not, however, precluded.

1.2.13 *Tank.* Cylindrical structure for water storage, based at or below grade. In general, this term shall refer to a structure having a wall height equal to or less than its diameter.

1.2.14 *Waterstop.* An impervious barrier installed to prevent passage of water through a construction or expansion joint between adjacent elements of concrete or shotcrete construction.

1.2.15 *Wire or strand winding.* The helical application of a continuous wire or strand for circumferentially prestressing the wall or dome ring of a circular tank.

Sec. 1.3 References

References identified refer to the latest revision available. Standards referenced herein shall comply with the appropriate documents and test methods included and referenced in the listed standard. The following is a list of references used in this AWWA standard:

ACI* 301/301M—Specifications for Structural Concrete.

ACI 302.1R—Guide for Concrete Floor and Slab Construction.

* American Concrete Institute, 38800 Country Club Dr., Farmington Hills, MI 48331

ACI 304R—Guide for Measuring, Mixing, Transporting, and Placing Concrete.

ACI 305R—Guide to Hot Weather Concreting.

ACI 306R—Guide to Cold Weather Concreting.

ACI 308R—Guide to Curing Concrete.

ACI 308.1/308.1M—Specification for Curing Concrete.

ACI 318/318M—Building Code Requirements for Structural Concrete and Commentary.

ACI 347—Guide to Formwork for Concrete.

ACI 350/350M—Code Requirements for Environmental Engineering Concrete Structures and Commentary.

ACI 350.3—Seismic Design of Liquid-Containing Concrete Structures and Commentary.

ACI 372R—Design and Construction of Circular Wire- and Strand-Wrapped Prestressed Concrete Structures.

ACI 503.2—Standard Specification for Bonding Plastic Concrete to Hardened Concrete with a Multi-Component Epoxy Adhesive.

ACI 506R—Guide to Shotcrete.

ACI 506.2—Specification for Shotcrete.

ACI 515.1R—Guide to the Use of Waterproofing, Dampproofing, Protective and Decorative Barrier Systems for Concrete.

ACI SP-2—Manual of Concrete Inspection, Tenth Edition.

ANSI/AWWA C652—Disinfection of Water-Storage Facilities.

ASCE 7-05—Minimum Design Loads for Buildings and Other Structures.

ASCE 7-10—Minimum Design Loads for Buildings and Other Structures.

ASTM[†] A185/A185M—Standard Specification for Steel Welded Wire Reinforcement, Plain, for Concrete.

ASTM A416/A416M—Standard Specification for Steel Strand, Uncoated Seven-Wire for Prestressed Concrete.

ASTM A421/A421M—Standard Specification for Uncoated Stress-Relieved Steel Wire for Prestressed Concrete.

ASTM A475—Standard Specification for Zinc-Coated Steel Wire Strand.

* American Society of Civil Engineers, 1801 Alexander Bell Drive, Reston, VA 20191.

† ASTM International, 100 Barr Harbor Drive, West Conshohocken, PA 19428.

ASTM A641/A641M—Standard Specification for Zinc-Coated (Galvanized) Carbon Steel Wire.

ASTM A648—Standard Specification for Steel Wire, Hard Drawn for Prestressing Concrete Pipe.

ASTM A653/A653M—Standard Specification for Steel Sheet, Zinc-Coated (Galvanized) or Zinc-Iron Alloy-Coated (Galvannealed) by the Hot-Dip Process.

ASTM A722/A722M—Standard Specification for Uncoated High-Strength Steel Bars for Prestressing Concrete.

ASTM A821/A821M—Standard Specification for Steel Wire, Hard-Drawn for Prestressed Concrete Tanks.

ASTM A882/A882M—Standard Specification for Filled Epoxy-Coated Seven-Wire Prestressing Steel Strand.

ASTM A1008/1008M—Standard Specification for Steel, Sheet, Cold-Rolled, Carbon, Structural, High-Strength Low-Alloy, High-Strength Low-Alloy with Improved Formability, Solution Hardened, and Bake Hardenable.

ASTM C836/C836M—Standard Specification for High Solids Content, Cold Liquid-Applied Elastomeric Waterproofing Membrane for Use with Separate Wearing Course.

ASTM C881/C881M—Standard Specification for Epoxy-Resin-Base Bonding Systems for Concrete.

ASTM C882/C882M—Standard Test Method for Bond Strength of Epoxy-Resin Systems Used with Concrete by Slant Shear.

ASTM C920—Standard Specification for Elastomeric Joint Sealants.

ASTM C957/C957M—Standard Specification for High-Solids Content, Cold Liquid-Applied Elastomeric Waterproofing Membrane with Integral Wearing Surface.

ASTM C1107/C1107M—Standard Specification for Packaged Dry, Hydraulic-Cement Grout (Nonshrink).

ASTM C1218/C1218M—Standard Test Method for Water-Soluble Chloride in Mortar and Concrete.

ASTM D695—Standard Test Method for Compressive Properties of Rigid Plastics.

ASTM D698—Standard Test Methods for Laboratory Compaction Characteristics of Soil Using Standard Effort (12,400 ft-lbf/ft³ (600 kN-m/m³)).

ASTM D1056—Standard Specification for Flexible Cellular Materials—Sponge or Expanded Rubber.

ASTM D1556—Standard Test Method for Density and Unit Weight of Soil in Place by the Sand-Cone Method.

ASTM D1557—Standard Test Methods for Laboratory Compaction Characteristics of Soil Using Modified Effort (56,000 ft-lbf/ft³) (2,700 kN-m/m³).

ASTM D1566—Standard Terminology Relating to Rubber.

ASTM D1752—Standard Specification for Preformed Sponge Rubber Cork and Recycled PVC Expansion Joint Fillers for Concrete Paving and Structural Construction.

ASTM D2000—Standard Classification System for Rubber Products in Automotive Applications.

ASTM D2240—Standard Test Method for Rubber Property—Durometer Hardness.

ASTM D2922—Standard Test Method for Density of Soil and Soil Aggregate in Place by Nuclear Methods (Shallow Depth).

ASTM D4253—Standard Test Methods for Maximum Index Density and Unit Weight of Soils Using a Vibratory Table.

ASTM D4254—Standard Test Methods for Minimum Index Density and Unit Weight of Soils and Calculation of Relative Density.

ASTM D6938—Standard Test Method for In-Place Density and Water Content of Soil and Soil-Aggregate by Nuclear Methods (Shallow Depth).

Fed Spec.* SS-S-210A—Sealing Compound, Preformed Plastic, for Expansion Joints and Pipe Joints.

Handbook of Molded and Extruded Rubber.[†]

ICC[‡] IBC—International Building Code.

Uniform Building Code.[§]

Post-Tensioning Manual.[¶] Sixth Edition, 2006.

US Army Corps of Engineers Spec.** CRD-C572—Corps of Engineers Specifications for Polyvinylchloride Waterstop.

Zia, P., H.K. Preston, N.L. Scott, and E.B. Workman. 1979. Estimating Prestress Losses. *Concrete International*, 1(6): 32–38.

* Naval Publications and Forms Center, 5801 Tabor Avenue, Philadelphia, PA 19120.

† Goodyear Tire and Rubber Company, 1144 East Market Street, Akron, OH 44316.

‡ International Code Council, 5203 Leesburg Pike, Suite 600, Falls Church, VA 22041.

§ International Conference of Building Officials (ICBO), 5360 Workman Mill Rd., Whittier, CA 90601.

¶ Post-Tensioning Institute, 38800 Country Club Drive, Farmington Hills, MI 48331.

** Naval Publications and Forms Center, 5801 Tabor Avenue, Philadelphia, PA 19120.

SECTION 2: MATERIALS

Sec. 2.1 Materials

Materials shall comply with the requirements of the Safe Drinking Water Act and other federal regulations for potable water, wastewater, and reclaimed water systems as applicable.

Sec. 2.2 Concrete and Shotcrete

2.2.1 *General.* The quality of concrete and shotcrete is of great importance to the structural integrity, reliability, durability, and watertightness of the completed tank. Therefore, care shall be taken throughout the tank construction to maintain close quality control of the source materials, mix proportions, forming, embedded items, placement, finishing, curing, and other details of the work. Concrete or shotcrete in potable-water tanks in contact with water shall

1. Be dense, well consolidated, and low in permeability, to retain water and enhance the serviceability, strength, and durability of the tank.

2. Provide a highly alkaline environment to prevent corrosion of embedded steel reinforcement.

3. Provide a surface that is uniform and well formed to facilitate cleaning and reduce maintenance. A smooth-form finish as specified in ACI 301/301M for formed concrete, a light broom or nozzle finish for shotcrete, and a light broom finish for precast panels are acceptable, provided good workmanship standards are observed.

2.2.2 *Concrete and shotcrete materials.* Concrete and shotcrete materials shall conform to the requirements of ACI 301/301M, ACI 350, and ACI 506.2 as modified herein. The mix proportions shall meet the strength requirements and physical properties of the purchaser's specifications. The minimum 28-day compressive strength of concrete shall be 4,000 psi (28 MPa) in walls, structural floors and roofs and 3,500 psi (24 MPa) in membrane floors. For corrosion protection of the steel reinforcement, concrete or shotcrete used in the core wall, top slab, or dome, and shotcrete for covering prestressed wire or strand, shall not contain water-soluble chloride ions in excess of 0.06 percent of the weight of the cement in the mix as determined by ASTM C1218/C1218M.

Concrete subjected to freeze–thaw cycling shall be air entrained according to ACI 301/301M. Wet-mix shotcrete for dome roofs in areas subjected to freeze–

thaw cycles shall be air entrained with an air content of 5 to 8 percent at the pump. Dry-mix shotcrete shall not be used in domes subject to freeze–thaw cycles.

2.2.2.1 *Shotcrete coat.* Shotcrete coat used for covering prestressed wire or strand shall consist of not more than three parts sand to one part cementitious material by weight; additional coats of shotcrete shall consist of not more than four parts sand to one part cementitious material by weight.

2.2.2.2 *Shotcrete mix.* Either the wet-mix or dry-mix process may be used for shotcreting unless the specifications require the use of a specific process. Shotcrete shall be proportioned for a 28-day compressive strength equal to that for which the core wall is designed but not less than 4,500 psi (31 MPa) unless otherwise specified.

2.2.3 *Cement mortar.* Mortar used for repair of concrete, encasement of waterstop, and patching form tie holes shall consist of not more than three parts sand to one part portland cement by weight and shall conform to the requirements of ACI 301/301M. Mortar shall not contain water-soluble chloride ions in excess of 0.06 percent of the weight of the cement in the mortar. Shrinkage-compensating mortars (nonshrink grout) shall be of the nonmetallic type as specified in Sec. 2.2.5.

2.2.4 *Cement grout.* Cement grout used for grouted or bonded vertical tendons in ducts shall contain not more than 0.45 parts water to one part portland cement by weight (approximately 5 gal [19 L] per sack of cement) and shall not contain water-soluble chloride ions in excess of 0.06 percent of the weight of the cement in the grout. Cement grout for tendons shall contain admixtures to reduce bleeding and grout settlement and shall be used according to the manufacturer's recommendation for this application.

2.2.5 *Nonshrink grout.* Nonshrink cement grout used for repair of honeycomb and other concrete repair and for patching form tie holes shall be a non-hydrogen-gas-liberating, nonmetallic grout meeting the requirements of ASTM C1107/C1107M, grade A or C, for nonshrink grout. This grout is not to be used for bonding of prestressed tendons or to come into contact with the wire or strand prestressed reinforcement.

Sec. 2.3 Mixing Water

Mixing water shall conform to the requirements of ACI 350.

Sec. 2.4 Admixtures

Admixtures shall comply with the requirements of ACI 301/301M or ACI 506.2 and shall not contain more than trace amounts of chlorides, fluorides, sulfides,

or nitrates because of their possible corrosive effect on the prestressed reinforcement. Materials in contact with potable water shall not impart taste, odor, or toxic chemicals to the water. All admixtures used in the concrete shall be compatible.

Sec. 2.5 Reinforcement

2.5.1 Nonprestressed reinforcement.

2.5.1.1 Bars and fabric. Deformed billet-steel bars; epoxy-coated steel bars; fabricated deformed steel bar mats; and steel welded-wire fabric, plain or deformed, for concrete reinforcement shall conform to the requirements of ACI 350 and the applicable ASTM standards referenced therein.

2.5.1.2 Strand. Strand for restraint cables shall meet the requirements of ASTM A416/A416M for seven-wire prestressing steel strand. The strand shall be protected with a fusion-bonded epoxy coating, grit-impregnated on the surface, conforming to ASTM A882/A882M, or it shall be galvanized. Galvanized strand shall meet the requirements of ASTM A416/A416M prior to galvanizing. The zinc coating for galvanizing shall meet the requirements of ASTM A641/A641M or ASTM A475, with a minimum weight per unit of uncoated wire surface of class A of these standards. Only hot-dipped galvanizing shall be permitted.

2.5.1.3 Steel-sheet diaphragms. Steel-sheet diaphragms for use as impervious membranes in the walls of prestressed concrete tanks shall be vertically ribbed with adjacent and opposing channels. The base of the channels (see Figure 1) shall be wider than the throat, thus providing a mechanical keyway anchorage between the inner and outer concrete or shotcrete. Uncoated steel sheet shall comply with ASTM A1008/A1008M, and hot-dipped galvanized sheet shall comply with ASTM A653/A653M. Diaphragm steel thickness shall be a minimum of 26 gauge with a minimum thickness of 0.017 in. (0.43 mm). Weight of zinc coating, where specified, shall be not less than G 90 of Table 1 of ASTM A653/A653M. The diaphragm sheets shall be continuous for the full height of the tank.

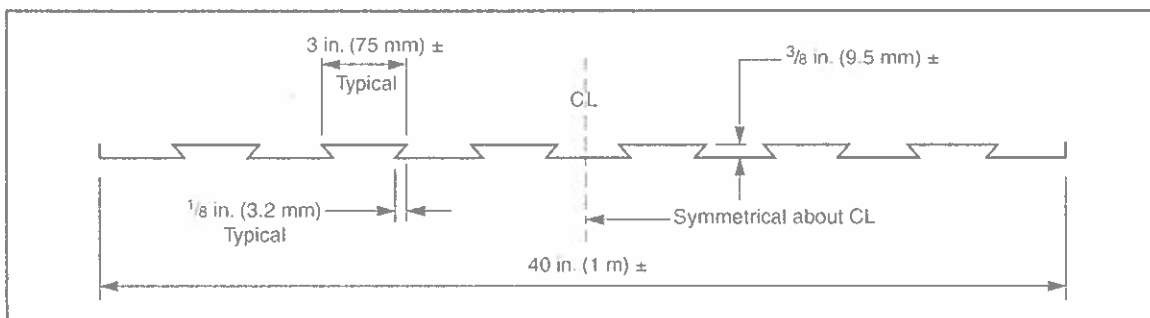

Figure 1 Example diaphragm sheet

2.5.2 *Prestressed reinforcement.*

2.5.2.1 Uncoated wire and strand. Uncoated prestressing wire and strand shall conform to the requirements of ACI 350 and the following applicable ASTM standards: hard-drawn steel wire to be helically wrapped, maintaining tension by mechanical means, shall conform to the requirements of ASTM A821/A821M; ASTM A648, class II; or ASTM A421/A421M, type WA. Steel wire, hard-drawn to be helically wrapped on the structure employing a wire-drawing die for back tension, shall conform to the requirements of ASTM A821/A821M. Steel prestressing strand shall conform to the requirements of ASTM A416/A416M.

2.5.2.2 Galvanized wire and strand. Galvanized prestressing wire and strand to be helically wrapped and tensioned shall meet the requirements of ASTM A821/A821M; ASTM A648, class II; or ASTM A421/A421M, type WA, for wire; and ASTM A416/A416M for strand. Zinc coating for galvanizing shall meet the requirements of ASTM A641/A641M or ASTM A475, with a minimum weight per unit area of uncoated wire surface of 0.85 oz/ft² (259 g/m²) or of class A of these standards. Only hot-dipped galvanizing shall be permitted.

2.5.2.3 Where galvanized wire is stressed on the structure by drawing through a die, the zinc coating remaining after stressing shall be a minimum of 0.50 oz/ft² (150 g/m²) of wire surface.

2.5.2.4 Splices. Splices for horizontal prestressed reinforcement shall be ferrous material compatible with the reinforcement and shall develop the full strength of the wire or strand. Anchor clamps and other accessories in contact with the prestressing elements may be galvanized or epoxy-coated iron or steel. Wire splice and anchorage accessories shall not weaken or otherwise compromise the prestressed reinforcement.

2.5.2.5 Vertical tendons. Tendons for vertical prestressed reinforcement of cast-in-place concrete core walls shall consist of high-strength strand or bars conforming to the requirements of ACI 350 and the material requirements of ASTM A416/A416M or ASTM A722/A722M. Tendon anchorages may be galvanized or epoxy coated for additional corrosion protection.

2.5.3 *Steel corrosion inhibitor.* Temporary corrosion protection of vertical prestressed reinforcement left in the ducts for more than 10 days before grouting shall be provided by volatile or vapor-phase inhibitors. These inhibitors are applied in solid form (a fine white powder) or liquid form that vaporizes and coats the surface of the prestressing steel with a stable organic nitrate that prevents corrosion

by passivating the metal. The corrosion inhibitor shall have no deleterious effect on the steel or bond strength between the cement or epoxy-resin grout and steel; and the corrosion inhibitor shall not prevent future corrosion protection of the prestressing steel by the grout.

Sec. 2.6 Elastomeric Materials

2.6.1 *Waterstops.* Waterstops shall be composed of plastic or other materials suitable for the intended use.

2.6.1.1 *Plastic waterstops.* Plastic waterstops shall be extruded from an elastomeric plastic material of which the basic resin is polyvinyl chloride (PVC). The PVC compound shall contain no scrapped or reclaimed material or pigment. The profile of the waterstop and its size shall be suitable for the hydrostatic pressure and movements to which it is exposed. The waterstop shall meet, as a minimum, the requirements of CRD-C572. Tests assuring conformity to these requirements shall either be made on material delivered to the jobsite or be certified by the manufacturer. Splices to the waterstop shall be according to the manufacturers' recommendations, or as detailed by the design professional and subject to review by the purchaser's representative.

2.6.2 *Bearing pads.* Bearing pads used in the floor-to-wall and wall-to-roof joints shall consist of neoprene, natural rubber, or polyvinyl chloride.

2.6.2.1 *Neoprene bearing pads.* Neoprene bearing pads shall have a minimum ultimate tensile strength of 1,500 psi (10.3 MPa), a minimum elongation of 500 percent, a maximum compressive set of 50 percent, and a hardness of 40 to 50 durometer according to ASTM D2240. Neoprene bearing pads shall contain only virgin crystallization-resistant polychloroprene as the raw polymer and the physical properties shall comply with ASTM D2000, line call-out M 2 BC 410 A1 4 B14 for 40-durometer material.

2.6.2.2 *Natural-rubber bearing pads.* Natural-rubber bearing pads shall contain only virgin natural polyisoprene as the raw polymer, and the physical properties shall comply with ASTM D2000, line call-out M 4 AA 4 14 A1 3.

2.6.2.3 *Polyvinyl chloride bearing pads.* Polyvinyl chloride for bearing pads shall meet the requirements of CRD-C572 for tanks in cold-weather regions.

2.6.3 *Sponge filler.* Sponge filler shall be closed-cell neoprene or rubber conforming to ASTM D1752, type 1, or to the requirements of ASTM D1056, types 2A1 through 2A4.

Sec. 2.7 Duct Material

2.7.1 *Grouted tendons.* Duct material for grouted vertical wall tendons shall be flexible or semiflexible steel or polyvinyl chloride pipe or tubing and shall be sufficiently strong to retain its shape and location during placement and vibration of the concrete. The inside diameter of the duct to be filled with portland-cement grout shall be a minimum of $\frac{3}{8}$ in. (9.5 mm) greater than the nominal diameter of the bar tendon, or the inside area of the duct shall be twice the area of the prestressed strand tendon. If the duct is to be filled with pumped epoxy, the annular space around the tendon may be reduced to the minimum size that will permit easy insertion of the tendon. Ducts shall be so constructed and sealed as to positively prevent the entrance of cement paste from the concrete and shall be equipped with suitable fittings and tubing at the base and top for flushing and pumping the grout or epoxy.

2.7.2 *Bonded tendons.* Duct material for fully bonded vertical tendons shall be semiflexible steel or corrugated polyvinyl duct. In addition to the requirements of Sec. 2.7.1, the duct shall be capable of transferring the stress from the tendon by bond or shear through the duct to the concrete along its full length.

Sec. 2.8 Concrete and Shotcrete Coatings

2.8.1 *Above grade.* In some cases, such as tanks located in areas subject to salt spray or other corrosive environments, coatings may be desired to seal the exterior surface of above-grade concrete and shotcrete dome roofs and shotcrete protection for the circumferential prestressed reinforcement. Coatings suitable for sealing the exterior of the tank shall be permeable to water vapor. Suitable coatings include rubber base (polyvinyl chloride-latex and polymeric vinyl-acrylic), acrylic elastomer and acrylic emulsion paints, and cementitious waterproofing compounds.

2.8.2 *Below grade.* Coatings are recommended for sealing the exterior surface of below-grade tanks where additional protection against aggressive soils is required. Coatings suitable for sealing the exterior of the tank wall include coal-tar epoxies and bitumastic compounds specifically formulated for this purpose.

2.8.3 *Other aggressive environments.* Additional information on exterior coatings and seal coats for an aggressive environment may be found in ACI 350 and ACI 515.1R.

Sec. 2.9 Sealants and Joint Fillers

2.9.1 *Sealant for steel diaphragm joints.* Sealants used in joints shall be polysulfide, polyurethane, urethane elastomer, or epoxy and shall provide watertightness under full tank head.

2.9.2 *Polysulfide sealant.* Polysulfide sealant shall be a two- (or more) component elastomeric compound of the appropriate type meeting the requirements of ASTM C920, type M, and shall have permanent characteristics of bond-to-metal or concrete surfaces, flexibility, and resistance to extrusion caused by hydrostatic pressure. Air-cured sealants shall not be used. The grade and class shall be appropriate for the intended use as recommended by the manufacturer.

2.9.3 *Polyurethane sealant.* Polyurethane elastomeric sealant used in interior tank construction joints and movement joints at the base of the wall, or in floor or roof slab joints shall meet the requirements of ASTM C920, class 25, of appropriate type and grade for permanent bond-to-concrete surfaces, flexibility, and resistance to extrusion caused by hydrostatic pressure. The sealant shall be multicomponent type M, of grade P for pourable, and grade NS for nonsag or gunnable. Sealant shall not impart taste, odor, or toxic chemicals to potable water.

2.9.4 *Preformed bitumen joint filler.* Preformed bitumen compound plastic joint filler for use in exterior movement joints shall be of the appropriate type conforming to Fed. Spec. SS-S-210A. Such filler or sealing compound shall not be used in interior floor, wall, or roof joints in contact with potable-water tank contents, or where the material may leach into the tank contents.

2.9.5 *Epoxy sealant.* Epoxy sealants shall be suitable for bonding to concrete, shotcrete, and steel, and shall be suitable for sealing the vertical joints between sheets of steel diaphragms. Epoxy sealants shall conform to the requirements of ASTM C881/C881M, type III, grade 1, and shall be a 100 percent solids, moisture-insensitive, low-modulus epoxy system. When pumped, maximum viscosity of the epoxy shall be 10 poise (1 Pa·s) at 77°F (25°C).

2.9.6 *Polyurethane filler.* Polyurethane filler used to fill voids between components in the wall base joint and seal around waterstops, base pads, restraint cable sleeves, and sponge fillers shall meet the requirements of ASTM C920, class 25, for single- or multiple-component types S or M, grade P or NS, as appropriate for the intended use.

2.9.7 *Urethane elastomer sealant.* Elastomer sealants shall be suitable for bonding to concrete, shotcrete, and steel, and shall be suitable for sealing the vertical joints between sheets of steel diaphragms. Urethane sealants shall be two component and conform to ASTM C836/C836M and ASTM C957/C957M, suitable for use in constant immersion. Sealant shall be suitable for potable water contact up to 180°F (82°C).

Sec. 2.10 Epoxy Bonding Agent

Epoxy resin used for increasing the bond of fresh, plastic concrete or mortars to hardened concrete shall be a two-component, 100 percent solids, moisture-insensitive epoxy adhesive meeting the requirements of ASTM C881/C881M, type II, grade 2, as specified in ACI 503.2. The bonding agent shall produce a bond strength, as determined by ASTM C882/C882M, greater than 1,500 psi (10.3 MPa), 14 days after the plastic concrete is placed. Epoxy in contact with potable water shall not impart taste or odor, or leach toxic trace elements into the water.

Sec. 2.11 Epoxy Mortar and Grout

2.11.1 *Epoxy mortar.* Epoxy mortar used for concrete repair shall be a noncorrosive and noncontaminating mixture of epoxy resin, catalyst, and fine aggregate proportioned in strict accordance with the manufacturer's instructions for the product and its intended use.

2.11.2 *Epoxy-resin grout.* Epoxy-resin grout used for corrosion protection of prestressed vertical tendons or for bonding the reinforcement within the duct shall be a two-component, moisture-insensitive, resin bonding system conforming to ASTM C881, of the type, grade, and class recommended by the manufacturer as suitable for these applications.

Sec. 2.12 Form Coatings

The form coating for concrete surfaces that will be in contact with potable water shall be of an organic base and shall be nonstaining and nontoxic.

SECTION 3: DESIGN

Sec. 3.1 Notation*

Notation used in various equations presented in Section 3 are defined as follows:

A_{ds} = total area of prestressing wires or strand for dome ring area, in in.²
(mm²), see Sec. 3.6.5

d = distance from face of support in in. (mm)

D = dead load in psf (N/m²)

E_c = short-term modulus of elasticity of concrete or shotcrete in psi (Pa)

* Caution should be used to be consistent throughout with use of units.

- E_v = vertical seismic load corresponding to the maximum design vertical spectral acceleration in lb (N) (see Sec. 3.6.3.1)
- f'_c = specified 28-day compressive cylinder strength of concrete or shotcrete in psi (Pa). (Refer to Sec. 5.3.4 for control of shotcrete strength)
- f_c = permissible compressive concrete or shotcrete stress in psi (Pa)
- f_{ci} = specified compressive cylinder strength of concrete or shotcrete (Refer to Sec. 5.6.2.5) at time of prestressing in psi (Pa)
- f_{pu} = specified ultimate tensile strength of steel prestressing wire, strand, or high-strength bars in psi (Pa)
- f_{se} = effective stress in prestressed reinforcement after losses in psi (Pa)
- f_{si} = maximum permissible initial stress in prestressed reinforcement before losses in psi (Pa)
- f_t = flexural tensile stress in extreme fiber of the core wall in psi (Pa)
- l_d = development length for bond in in. (mm)
- L = roof live load in psf (N/m^2), in accordance with ASCE 7
- P_u = factored (uniformly distributed) unit dead and live design load on dome shell in lb/ft^2 (N/m^2)
- r_d = mean radius of dome shell in ft (m)
- r_i = average maximum radius of curvature over a dome imperfection area in ft (m)
- S = snow load in psf (N/m^2), in accordance with ASCE 7
- t_c = core-wall thickness in in. (mm)
- t_d = dome-shell thickness in in. (mm)
- u = nominal bond stress in concrete or shotcrete in psi (Pa)
- V_c = nominal shear stress in concrete or shotcrete in psi (Pa)
- V_{max} = maximum shear stress in reinforced section in psi (Pa)
- W = total dead and live load on dome, exclusive of dome ring in lb (N)
- β_c = buckling reduction factor for creep, nonlinearity, and cracking of concrete
- β_j = buckling reduction factor for geometrical imperfections from a true spherical surface, such as local increases in radius
- ω = half central angle of dome shell in degrees
- ϕ = buckling resistance factor

Sec. 3.2 Design Method

Tank design shall be based on elastic analysis methods and shall take into account effects of all loads and prestressing forces during and after tensioning, and conditions of edge restraint at wall junctions with floor and roof. Stresses shall

not exceed allowable service stresses specified in Sec. 3.4. Consideration shall also be given to the effects of all loads and load combinations, including stresses induced by temperature and moisture gradients. The recommendations herein pertain to service-load conditions and serviceability requirements. However, to ensure the safety of the structure, the design must also meet the strength requirements of this standard and ACI 350. All applicable sections of the latest edition of ACI 350, including supplements and the chapters describing precast and prestressed concrete, shall be followed except when supplemented or modified by provisions of this standard.

Sec. 3.3 Design Loads

Loads indicated in this section are those most frequently encountered in prestressed concrete tank design and shall be included in the design calculations. Loadings, including prestressing forces and their placement, shall follow governing codes.

3.3.1 *Wall design loads.*

3.3.1.1 Internal pressure—the pressure from water at maximum overflow level.

3.3.1.2 Dead loads, including all attached accessories and appurtenances.

3.3.1.3 Backfill loading—the lateral pressure from earth backfill, symmetrical or asymmetrical. Net lateral loads, including those caused by unequal backfill, shall be determined by rational methods of soil mechanics based on foundation and soils investigations. Surcharge loads on backfilled surfaces shall be considered.

Backfill pressure shall not be used to reduce the amount of prestressing force required for resisting internal water pressure. Backfill forces shall be based on soil parameters established by a registered design professional experienced in soils.

3.3.1.4 Minimum design loadings for wind and earthquake. These loadings shall conform to requirements of local building codes applicable to the site. These might include the applicable sections of the International Building Code or ASCE 7. Seismic design criteria for prestressed concrete tanks are stated in Section 4 as appropriate.

3.3.1.5 Construction loads. Effects of construction, including loads resulting from equipment, materials, and construction methods to be used.

3.3.1.6 Hydrostatic load. External hydrostatic pressure on the floor and wall, including flood and wave loads, if any.

3.3.1.7 Operating loads and system surges.

3.3.1.8 Thermal and moisture loads. Thermal and moisture gradients as follows:

1. Radially, through the thickness of the wall.
2. Vertically, that occur between the buried and exposed portion of the wall.
3. Between the wall and roof or floor.

3.3.1.9 *Prestressing loads.* Effects on the wall caused by the application of prestressing forces, including those caused by nonuniform distribution of prestressing forces temporarily induced during the stressing operations and in the completed structure.

3.3.2 *Roof design loads.*

- 3.3.2.1 Dead loads, including sustained surcharges.
- 3.3.2.2 Earth, snow or ice, and other live loads.
- 3.3.2.3 Construction loads.
- 3.3.2.4 Wind loads.
- 3.3.2.5 Earthquake loads.
- 3.3.2.6 Appurtenance loads.
- 3.3.2.7 Operational loads, if any.
- 3.3.2.8 Loads created by roof openings.

3.3.3 *Floor design loads.*

- 3.3.3.1 Dead loads.
- 3.3.3.2 Water loads.
- 3.3.3.3 Earthquake loads.
- 3.3.3.4 Uplift caused by groundwater or expansive soils.
- 3.3.3.5 Radial forces from the base of the tank wall.
- 3.3.3.6 Differential and total settlement.
- 3.3.3.7 Construction loads.

3.3.4 *Control of loads.* Consideration shall also be given to the following load control techniques and their safety margins:

- 3.3.4.1 Overflow systems.
- 3.3.4.2 Venting.
- 3.3.4.3 Internal freeboard to provide room for sloshing during an earthquake.

3.3.4.4 Perimeter and underfloor drainage systems to limit hydrostatic pressures.

3.3.4.5 *Drainage.* Provisions for drainage of surface water from earth backfill and roof runoff away from the structure, or use of a free-draining granular backfill or composite drainage panels adjacent to the wall, should be considered for reducing hydrostatic loading on the exterior face of the tank wall and floor.

Sec. 3.4 Allowable Stresses

3.4.1 *Concrete and shotcrete.* Service-load stresses shall be limited to provide protection against leakage into or out of the tank and against corrosion of the reinforcement. Cracking under predominantly flexural stresses shall be controlled to limit crack depth and width. The stresses for concrete and shotcrete shall not exceed the values indicated in Table 1.

3.4.2 *Prestressed reinforcement.*

3.4.2.1 Maximum permissible initial prestress. Maximum permissible initial stress f_{si} in any wire or strand on the wall, or in vertical threaded bar prestressed reinforcement, shall not exceed $0.75f_{pu}$. Maximum initial stress for anchored strands in vertical prestressed reinforcement, after anchorage and elastic losses, shall not exceed $0.70f_{pu}$.

Table 1 Allowable stresses in concrete and shotcrete

| Description | Notation | Allowable Stresses* |
|--|-----------|--|
| Compression: horizontal or vertical in extreme fiber. | f_c | $0.55f'_c$ initial; $0.45f'_c$ final. |
| Tension: vertical, in extreme fiber of all tanks without a diaphragm. All tanks without a diaphragm shall be vertically prestressed. | f_t | Vertical flexural tensile stresses to be reduced to zero by vertical prestressing as in Sec. 3.5.3 or taken by the auxiliary nonprestressed reinforcement at the stresses in paragraphs of Sec. 3.4.3. |
| Tension: vertical in tanks with a diaphragm. | f_t | 100 percent of the tensile force shall be taken by the reinforcing steel or diaphragm at the stresses specified in the paragraphs of Sec. 3.4.3. |
| Shear: as a measure of diagonal tension at a distance d from the face of the support, psi. Members with no web reinforcement. | V_c | $1.1\sqrt{f'_c}$ |
| Members with vertical or inclined web reinforcement, | V_{max} | $5\sqrt{f'_c}$ (Increased stress allowed for properly designed reinforcement.) |
| Slabs with footings: peripheral shear. | V_c | $2\sqrt{f'_c}$ |
| Development length and bonding reinforcement: deformed bars and welded wire fabric | l_d | Development length l_d shall be computed as a measure of bond resistance according to recommendations of ACI 350. |
| Steel diaphragm: nominal bond stress in concrete or shotcrete | u | $2.5\sqrt{f'_c}$ (See Sec. 3.4.3.1) |

*Coefficients shown are for values of f'_c expressed in pounds per square inch (psi). Refer to Sec. 3.1 for definition of notation.

Table 1M Metric Conversion

A. Shear in members with no web reinforcement:

$$V_c = 1.1\sqrt{f'_c}$$

$$[V_c = 92\sqrt{f'_c}] \text{ in SI system}$$

B. Shear in members with vertical or inclined web reinforcement:

$$V_{max} = 5\sqrt{f'_c}$$

$$[V_{max} = 415\sqrt{f'_c}] \text{ in SI system}$$

C. Peripheral shear in slabs and footings:

$$V_c = 2\sqrt{f'_c}$$

$$[V_c = 170\sqrt{f'_c}] \text{ in SI system}$$

D. Steel diaphragm—nominal bond stress in concrete or shotcrete:

$$u = 2.5\sqrt{f'_c}$$

$$[u = 210\sqrt{f'_c}] \text{ in SI system}$$

3.4.2.2 Long-term stress loss. Long-term stress losses caused by shrinkage and creep of concrete or shotcrete and relaxation in prestressed reinforcement shall be calculated according to the recommendations in Zia et al. (1979)^{*} or assumed to be 25,000 psi (170 MPa).

3.4.2.3 Maximum design stress. Maximum design stress in prestressed wire, strand, or high-strength bars f_{se} for structures subject to full design load, after deduction for stress losses, shall not exceed $0.65f_{pu}$.

3.4.3 *Nonprestressed reinforcement.* Nonprestressed reinforcement shall be designed according to the requirements of the Alternate Design Method in ACI 350. The strength requirements of ACI 350 shall also be satisfied. Because crack control is of paramount importance to prestressed concrete structures, additional nonprestressed reinforcement is often used in areas of localized stress to control cracking and preclude the contained liquid from reaching the prestressing elements. Low stress in reinforcement at service loads is good insurance against undesirable performance of these structures. Recommended maximum stresses and spacing for deformed bars, as provided in ACI 350, shall not be exceeded.

^{*}Zia, P., H.K. Preston, N.L. Scott, and E.B. Workman. 1979. Estimating Prestress Losses. *Concrete International*, 1(6): 32–38.

3.4.3.1 Nonprestressed reinforcement and diaphragm. Nonprestressed reinforcement may consist of bars or welded wire fabric. The area of steel-sheet wall diaphragm parallel to the direction of its channels (vertical) may also be used to contribute to the vertical reinforcement of the wall, provided the diaphragm is located close enough to the inside or outside surface to effectively control cracking caused by vertical bending moments.

3.4.3.2 Diaphragm tensile stress. For diaphragm-type tanks, the allowable tensile stress in the diaphragm shall not exceed 18,000 psi (120 MPa). Design shall otherwise be according to the requirements of ACI 350.

3.4.3.3 Circumferential tension. Nonprestressed steel reinforcement shall not be used to resist any portion of circumferential tension in the wall. It may be used to resist circumferential tension in the dome ring due to roof live load as provided in Sec. 3.6.5.2.

3.4.4 *Shotcrete core-wall alternative design (Type II core wall with 8-gauge wire only).* An alternative shotcrete core-wall design method shall be allowed based on the following stipulations, which must be used in conjunction with Sec. 3.5.2.2. All allowable stresses previously described in Sec. 3.4 also apply to this alternative shotcrete core-wall design.

3.4.4.1 Maximum design initial stress. Maximum design initial stress f_{sid} used in design shall not exceed $0.63f_{pu}$.

3.4.4.2 Maximum design final stress. Maximum design final stress f_{sed} used in design shall not exceed $0.55f_{pu}$.

3.4.4.3 Long-term losses. Long-term losses shall be 30,600 psi. These long-term losses incorporate residual compression.

3.4.4.4 Core-wall allowable stress from initial prestressing. Allowable stress in the core wall from initial prestressing shall be $0.5f'_c$ for direct horizontal compression only.

3.4.4.5 Core-wall allowable stress from final prestressing. Allowable stress in the core wall from final prestressing shall be $0.45f'_c$ with a maximum of

$$f'_c = 1,250 \text{ psi} + (75 \text{ psi/in.} \times t_c)$$

$$f'_c = 8.62 \times 10^6 \text{ Pa} + (2.04 \times 10^4 \text{ Pa/mm} \times t_c) \text{ (in SI system)}$$

3.4.4.6 Wall thickness. This alternative shotcrete core-wall design shall result in a tank wall thickness not less than that required by the base method of Sec. 3.4 and the requirements of Sec. 3.5.2.1.

3.4.4.7 *Prestressing wire area.* This alternative shotcrete core-wall design shall result in at least the same amount of prestressing wire area as required by the base method of Sec. 3.4 and the requirements of Sec. 3.5.2.1.

Sec. 3.5 Wall Design

3.5.1 *Design calculations.* Wall design shall be based on elastic cylindrical shell analyses for stresses and deformations caused by loads outlined herein. The design calculations made by the registered design professional in responsible charge of the design shall be made a matter of record, available at the request of the purchaser's representative and approving authority.

3.5.2 *Circumferential prestressing force.* Circumferential prestressed reinforcement shall be provided to resist all forces caused by internal loads, after accounting for all stress losses and for residual compression.

3.5.2.1 *Minimum final circumferential prestressing force.* The combined effect of the final circumferential prestressing force and water load at any point on the wall shall provide not less than 200 psi (1.4 MPa) residual compression for the aboveground portion of the tank wall, tapering linearly to 50 psi (340 kPa) at 6 ft (1.8 m) below grade. For restrained base-joint construction, the equivalent prestress force shall be provided as if the base were free to move radially. For empty open-top tanks, the final circumferential prestress force shall provide not less than 400 psi (2.8 MPa) residual compression in the concrete or shotcrete core wall at any point on the wall. For a tank covered with a concrete roof that is monolithic with or bears on and restrains the top of the wall, the final circumferential prestress force for the empty tank shall provide not less than 240 psi (1.7 MPa) residual compression at any point in the core wall when free joints are assumed at the top and bottom.

3.5.2.2 *Shotcrete core-wall alternative design.* If the shotcrete core-wall alternative design of Sec. 3.4.4 is used, the 8-gauge wire shall be designed for total long-term losses of 30,600 psi, which accounts for residual compression.

3.5.3 *Vertical prestressing force.* In nondiaphragm tanks, vertical prestressed reinforcement shall be provided to produce, after allowance for prestress losses, a minimum axial average compression of 200 psi (1.4 MPa) in the concrete core wall. Looped strand tendons shall not be used. Vertical tendons shall have end anchors at the top and bottom of the wall. The maximum spacing of vertical tendons shall not exceed seven times the wall thickness or 50 in. (1.3 m), whichever is less. Supplemental nonprestressed steel reinforcement shall be provided to resist part of the vertical bending moments resulting from edge restraint, moisture and temperature gradients, and other applied loads. For example, vertical nonprestressed reinforcement may be

required at the lower portion of the wall (inside face) to control concrete tension as the circumferential prestressing is applied.

3.5.4 *Core-wall thickness.* The thickness of the concrete or shotcrete core wall, prior to prestressing, shall be such that membrane shell stresses are within the allowable stresses; the minimum dimensional limits are as follows:

- 8 in. (200 mm) for type I core walls,
- 3½ in. (90 mm) for type II core walls,
- 4 in. (100 mm) for type III core walls, and
- 7 in. (180 mm) for type IV core walls.

3.5.4.1 *Unusual tank dimensions.* For tanks with unusual dimensions, unusual vertically applied loads, or other unusual loading, minimum wall thickness shall be based on analyses that include an evaluation of wall stability, buckling, and moments introduced by prestressing and other forces.

3.5.4.2 *Core wall with diaphragm.* For core walls with a diaphragm, the diaphragm shall be embedded with a minimum of 1.0 in. (25 mm) interior cover. For all core walls incorporating a diaphragm at the exterior face of the wall, at least 0.5 in. (13 mm) of shotcrete cover shall be applied to the exterior of the steel diaphragm prior to wire or strand wrapping to fill the diaphragm channels or flutes and preclude wrapping the horizontal prestressed reinforcement directly on the exposed steel diaphragm.

3.5.5 *End restraint.* Restraint of the wall at either the base or roof causes significant vertical bending stresses that must be evaluated and included in the design.

3.5.5.1 *Wall-joint details.* The designer shall consider all wall boundary conditions resulting from the construction-joint details to be used at the top and bottom of the wall. Particular attention shall be given to restraint of translation and rotation, which varies, depending on whether the joint is monolithic, allowed to slide (friction force), or allowed to move by deforming an elastomeric pad (rigidity of the pad) (see Sec. 4.2.1). Use appropriate values of recognized test data and record the values in the project calculations. For guidance to the designer, the *Handbook of Molded and Extruded Rubber*, second edition, provides data on rubber pads for various durometers of hardness and shape factors.

3.5.6 *Vertical nonprestressed reinforcement.* Tank core walls reinforced vertically with only nonprestressed steel reinforcing shall contain a watertight steel diaphragm. In the diaphragm wall, nonprestressed reinforcement shall be used to resist the vertical flexural tension caused by edge restraints when either internal

water pressure, external loadings, or circumferential prestressing are applied. The diaphragm may preclude the necessity for additional nonprestressed reinforcement in free base tanks and for effects resulting from temperatures and moisture gradients where the wall is a thin section and temperature conditions are not extreme. A minimum vertical-reinforcement ratio of 0.0025 on each face of the wall section shall be provided by the diaphragm and, if required, additional supplemental nonprestressed reinforcement.

3.5.6.1 *Maximum stress.* Maximum tensile stress for regular nonprestressed steel reinforcement used to resist vertical bending stresses caused by service loads shall be 18,000 psi (120 MPa) for grades 40, 50, and 60. Bar size shall be no greater than $\frac{3}{4}$ in. (19 mm) (No. 6), and bar spacing shall not exceed 12 in. (300 mm). The cross-sectional area of the steel diaphragm used in a tank core wall may be included as part of the nonprestressed vertical steel reinforcing requirements, provided the diaphragm is close enough to the face of the wall to control cracking caused by bending moment in the wall.

3.5.6.2 *Minimum interior cover.* The minimum concrete or shotcrete interior cover over steel diaphragms, welded wire fabric, and bar reinforcement shall be not less than 1 in. (25 mm) or one and a half times the diameter of nonprestressed steel deformed bars, whichever is greater. Cover for vertical tendon anchorages shall not be less than 2 in. (50 mm). For containment of aggressive water, additional cover shall be provided for the reinforcement.

3.5.7 *Seismic forces.* Forces and moments resulting from seismic accelerations of water loads, dead loads, and external loads shall be taken into account in the design. The design shall include the construction details to be provided at the top and base of the wall. Restraint cables, shear keys, dowels, elastomeric pads with or without confinement ring joints, and monolithic joints are examples of systems available to resist these forces. Stresses and deflections produced by seismic effects in all components shall be controlled. Seismic loading and design is covered in Section 4.

3.5.8 *Shear forces.* Reinforcement of joints must be sufficient to resist the following loads and any combination thereof:

1. Water
2. Backfill
3. Seismic
4. Prestressing
5. Wind
6. Other

3.5.9 *Bearing pads.* In order to minimize vertical bending moments in the wall, it is important to keep the hardness in the range of 30 to 50 durometers and the pad thickness under the wall at a ½-in. (13-mm) minimum. See Sec. 4.6.4 for minimum width-to-thickness ratio and minimum length to thickness ratio for pads. When a pad is required between the wall and roof, it shall have a minimum thickness of ½ in. (13 mm). The required pad area is determined after considering the vertical load, percent compression, and allowable deformation of the pad.

3.5.10 *Wall openings.* Wall penetrations often require the transfer of prestress forces around the wall opening, which may be provided by the use of a stress plate or displacing the circumferential prestress reinforcement above and below the opening. Consideration shall be given to localized wall stresses, the spacing and protection of the prestress reinforcement, and waterstop integrity.

Sec. 3.6 Dome-Roof Design

3.6.1 *General.* A number of different types of concrete and shotcrete dome designs have been successfully used as covers for prestressed concrete tanks. The most common types used today in the United States are spherical shells of cast-in-place or precast concrete. The joint between the dome edge ring and the top of the wall may be *fixed* by extension of the wall reinforcement to restrict radial translation and rotation, *pinned* to restrain against translation, or *separated* by an elastomeric bearing pad to minimize restraint of both translation and rotation (see Figure 2).

The dome roof may also be constructed of double-curved, precast concrete panels. The panels are connected at cast-in-place intermediate circumferential rings and a dome edge ring. The pinned-type joint of Figure 2B is generally used with precast concrete and cast-in-place domes and the other two types of joints with cast-in-place domes. Provision must be made in the design of the fixed connection of Figure 2A for the effects of stress transfer from the dome to the wall and from the wall to the dome as discussed in Sec. 3.6.4. When the dome ring is separated from the tank wall, as in Figure 2C, the joint design may require means to prevent lateral displacement of the dome caused by seismic loading, as discussed in Sec. 3.6.5.4.

3.6.1.1 *Rise-to-span ratio.* Most concrete or shotcrete domes built in the United States are low-rise spherical shells with rise-to-span ratios between 1:16 and 1:8. Domes with greater rise-to-span ratios than 1:8 present a problem in placement and finishing at the edge without use of a top form, and ratios of 1:16 or less require larger edge ring prestress and are generally less economical. A rise-to-span ratio of 1:10 is typical.

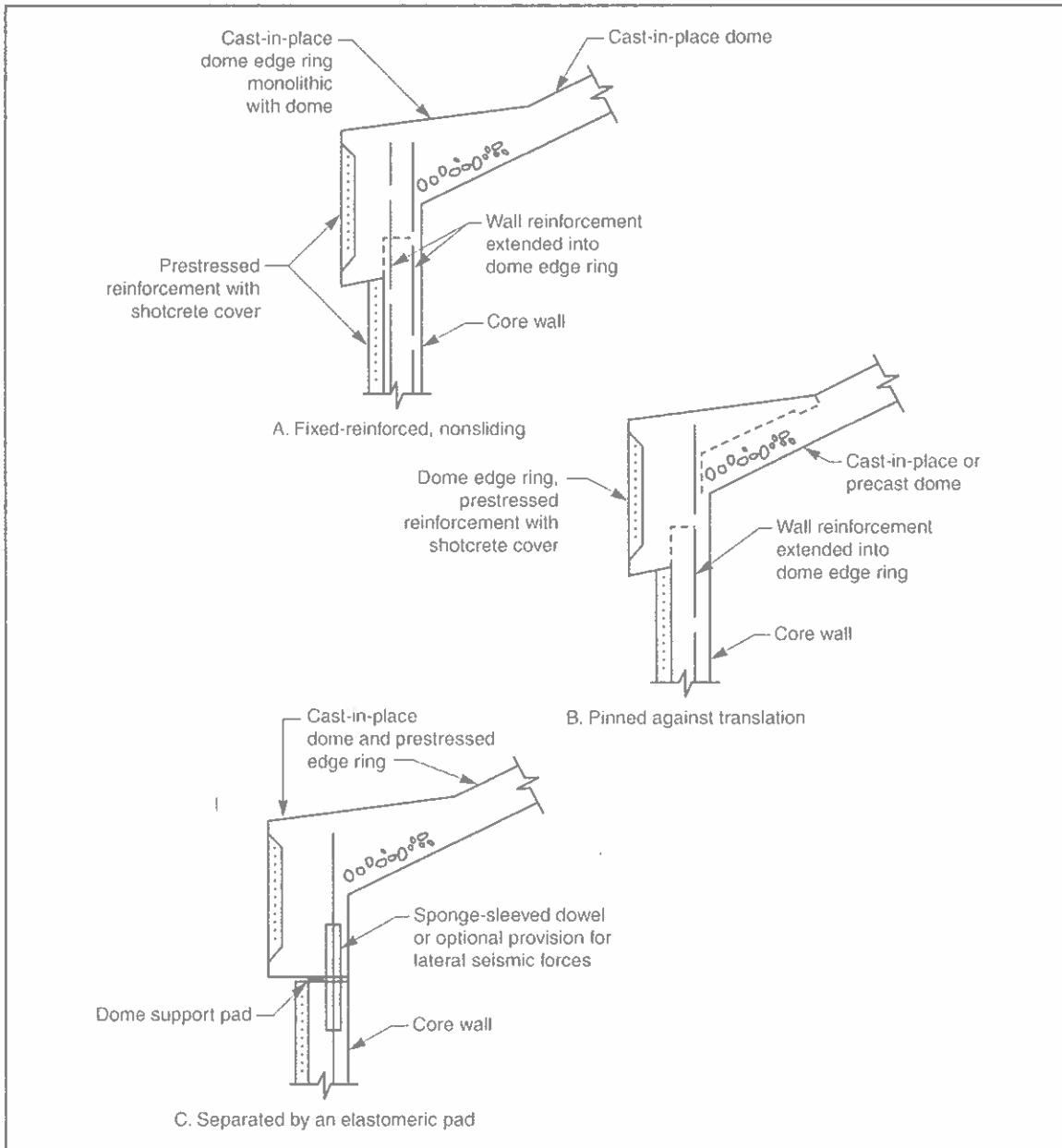

Figure 2 Joints between wall and dome edge ring

3.6.1.2 Severe exposure and freeze-thaw conditions. Consideration shall be given in the dome design for severe exposure conditions. Dry-mix shotcrete shall not be used in construction of domes in areas subject to freeze-thaw cycles.

3.6.1.3 Other dome designs and connections. The cast-in-place concrete, precast concrete, and shotcrete dome designs described herein are for typical dome roofs commonly used in current practice. It is not the intent of this

standard to preclude other dome-to-wall connections and alternative cast-in-place dome designs that are in conformance with ACI 350.

3.6.2 *Design method.* Concrete or shotcrete dome roofs shall be designed on the basis of elastic shell analysis. A circumferentially prestressed dome edge ring or its equivalent shall be provided at the base of the dome shell if required to resist the horizontal component of the dome thrust.

3.6.3 *Thickness and reinforcement.* Dome shell thickness is governed by either buckling resistance, by minimum thickness for practical construction, or by cover requirements for corrosion protection of the reinforcement. Minimum thickness of concrete or shotcrete domes shall not be less than 3 in. (75 mm).

3.6.3.1 *Thickness for buckling resistance.* A method for determining the minimum thickness of a concrete spherical dome shell to provide adequate buckling resistance is given in Zarghamee and Heger (1983).^{*} This method is based on the theory of dome shell stability with consideration of the effects of concrete creep, geometric imperfections, and successful experience with existing tank domes having large radius-to-thickness ratios. Based on these criteria, the minimum recommended dome thickness for buckling may be determined from Eq 3-1.

$$\min t_d = r_d \sqrt{\frac{1.5 P_u}{\phi \beta_i \beta_c E_c}} \quad (\text{Eq 3-1})$$

$$\min t_d = 1,000 r_d \sqrt{\frac{1.5 P_u}{\phi \beta_i \beta_c E_c}} \quad (\text{in SI system})$$

The conditions that determine the factors ϕ , β_i , and β_c are discussed in Zarghamee and Heger (1983). The values for these factors, which are given below, are recommended for use when domes are designed for conditions where live load is 12 lb/ft² (575 Pa) or more, water is stored inside the tank, dome thickness is 3 in. (75 mm) or more, f'_c is 4,000 psi (28 MPa) or more, normal-weight aggregates are used, and dead load is applied (i.e., shores removed) not sooner than seven days after concrete placement, with curing as required in ACI 301/301M. Recommended values for the terms for such domes are

P_u = maximum distributed load resulting from the following loading conditions:

1. $1.4D$

^{*}Zarghamee, M.S., and E.J. Heger. 1983. Buckling of Thin Concrete Domes. *ACI Journal Proceedings*, 80(6): 487-500.

2. $1.2D + 1.6(L \text{ or } S)$
3. $1.2D + 0.2S + 1.0E_v^*$

Where:

D = dead load in psf

L = roof live load in psf, per ASCE 7

S = snow load in psf, per ASCE 7

E_v = vertical seismic load, corresponding to the maximum design vertical spectral acceleration determined from site-specific study, A_v , or $(2/3)(S_{DS})$

For site-specific ground motions:

$$E_v = A_v(D + 0.2S)$$

For mapped ground motions:

$$E_v = (2/3)(S_{DS})(D + 0.2S)$$

$\phi = 0.6$ for buckling-controlled sections

$\beta_i = (r_d/r_i)^2$, where r_i = averaged maximum radius of curvature over a dome imperfection area with a diameter of $2.5(r_d t_d)^{0.5}$. In the absence of other criteria, the maximum r_i may be taken as $1.4r_d$ and in this case

$$\beta_i = 0.5$$

$\beta_c = 0.44$ for loading condition 1,

$\beta_c = 0.44 + 0.003S$ but not greater than 0.53 for loading condition 2, and

$\beta_c = 0.44 + 0.26\chi$ for loading condition 3,

where χ = seismic load as fraction of total factored dead plus seismic load

$$E_c = 57,000(f_c')^{0.5} \text{ for normal-weight concrete or shotcrete}$$

Precast concrete panel dome shells may be used in dome construction provided they are watertight and the designer makes allowance for joints between panels that are not equivalent in thickness, strength, or resistance to buckling to a monolithic shell.

3.6.3.2 Area of reinforcing steel. The area of reinforcing steel in a dome, excluding the dome ring, shall be not less than 0.25 percent of the concrete cross-sectional area ($0.0025bt_d$) in both the circumferential and radial directions. The reinforcement shall be placed approximately at the mid-depth of the shell, except

*The seismic horizontal acceleration has a negligible effect on the dome buckling and shall not be included when determining the dome buckling capacity. Importance factor $I = 1.0$ and response modification factor $R_I = 1.0$ shall be used in determining minimum thickness of the dome in lieu of the values given in Table 2 and Table 3 of Section 4.

in the edge region, where two layers of reinforcement shall be used in the radial direction. The second layer of reinforcement may be eliminated if the designer determines it is not required.

3.6.4 Dome edge region. The edge region of the dome and the top region of the wall are subject to bending stresses resulting from shell edge restraint provided by the dome edge ring and cylindrical wall. These stresses can be reduced to levels that do not impair tank performance by the proper design of the dome-wall joint as described in this section. Factors that affect bending stresses are type of joint (reinforced nonsliding, pinned, or separated), size of dome ring, initial prestress force on the ring and on the adjacent wall, and the thickness of the dome edge region. The edge effects may require thickening of the dome near its edge, radial reinforcement in the top and bottom of the dome edge region, and vertical reinforcement in each face of the upper tank wall.

3.6.5 Dome edge ring. Circular prestressing of the dome edge ring is used to eliminate or control circumferential tension in the dome ring and to reduce edge bending effect in the dome and upper region of the tank wall.

Unless a more accurate analysis is made, the area of prestressing steel to resist total dead and live load W shall be taken as

$$A_{ds} = W \cot \omega / (2\pi f_{sr})$$

$$A_{ds} = W \cot \omega / (2\pi f_{sr} \times 10^6) \text{ (in SI system)}$$

3.6.5.1 Prestressing force. Prestressing force may be provided to counteract only that tension caused by dead load plus all losses. If prestressing for less than the full live load is used, sufficient area of prestressing steel must be maintained at reduced stress, or additional nonprestressed reinforcing shall be added to provide strength according to the requirements of ACI 350. Prestressing in excess of that required for dead-load thrust increases bending and compression stresses in the dome ring, in adjacent regions of the dome, and in the upper part of the wall when it is monolithic with the ring.

3.6.5.2 Dome edge ring stress. The dome edge ring is often proportioned such that the initial nominal compressive stresses are limited within a range of 400 psi (2.8 MPa) to 1,000 psi (7 MPa) based on the net cross section of the ring, excluding haunches or adjacent wall.

3.6.5.3 Shrinkage and temperature. Nonprestressed reinforcing steel shall be used in the dome ring to control shrinkage and temperature effects prior

to prestressing. The minimum area of circumferential steel shall be 0.0025 times the cross-sectional area of the dome ring.

3.6.5.4 *Dome displacement.* When the dome ring is separated from the tank wall, as in Figure 2C, positive means, such as keyways, flexible restraint cables, or doweling, shall be provided to prevent excess lateral displacement of the dome in the event of seismic activity. Where such a detail is used, the joint shall be designed to accommodate controlled radial movement at the top of the wall during circumferential prestressing and fluctuations in temperature and water level.

3.6.5.5 *Dome runoff.* All roof-wall joints shall be designed to prevent dome roof runoff from penetrating the interface between the core wall and the circumferential prestressed wall reinforcement.

Sec. 3.7 Other Roof Designs

Other types of roof structures constructed of concrete, steel, aluminum, or fiberglass-reinforced plastic may be used if designed in conformance with currently accepted standards. The design shall provide a weathertight roof to prevent leakage and contamination of the tank contents. Consideration shall be given for severe exposure conditions and condensation on the underside of the roof. Concrete slab roofs shall be reinforced to resist temperature and shrinkage stresses. The design shall include crack control to prevent leakage and corrosion of the reinforcement. Nonprestressed cast-in-place or precast concrete slab roofs for potable-water tanks shall have a minimum slope of 1½ percent, or a suitable coating or membrane shall be provided to prevent liquids from leaking into the tank. Nonprestressed, steel-reinforced concrete flat slabs shall conform to the applicable requirements of ACI 350, with special attention to crack control.

Sec. 3.8 Floor Design

The floor may be either structural or membrane type.

3.8.1 *Structural floors.* Reinforced structural floors may be required for supporting the tank contents where the subbase is not adequate to directly carry imposed loads, where soil support stiffness may be nonuniform, for resisting maximum hydrostatic uplift forces, for locations with highly plastic clays, expansive soils, or for other unusual foundation conditions. Structural reinforced-concrete floors used for these purposes shall be designed according to the requirements of ACI 350 with special attention to crack control. Under some conditions, anchorage to underlying foundation strata or a sufficiently heavy concrete floor system can provide a satisfactory solution to hydrostatic uplift. Design of the floor and the

footing shall consider the differential stiffness of the soil support and the concrete encasements to be placed under the floor.

3.8.2 Membrane floors. In cast-in-place concrete membrane floors, loads are assumed to be transmitted to the subbase directly through the membrane. Minimum thickness of the membrane shall be 4 in. (100 mm). Floors shall be placed continuously in sections as large as practicable to decrease the length of construction joints and potential leakage problems related to their presence. Precautions shall be taken with large floor sections to limit long-term shrinkage effects. Hydrostatic uplift when the tank is empty or when the tank water level is lowered during operation shall be precluded by adequate surface drainage, a perimeter drain around the tank wall foundation, and underdrainage, if necessary. For crack control in the floor, the minimum reinforcement in each direction in the horizontal plane shall be no less than 0.5 percent of the concrete area.

3.8.3 Watertightness. Where construction or expansion joints are provided in floors, waterstops shall be used to ensure watertightness under a head of water equal to the height of the tank (see Figure 3). In expansion joints, an acceptable joint sealant or filler shall be used in addition to the waterstop to prevent entry of foreign material into the joint.

The slab at the joint may be thickened to allow additional space for the waterstop and reinforcement. For a restrained joint, the reinforcement shall be continuous through the joint. Additional nonprestressed reinforcement shall be provided in the thickened portion of slab plus 2 ft (0.61 m) of the subsequently placed membrane slab parallel to the construction joint to control cracking. Alternative designs with nonrestrained (unbonded) joints are acceptable, provided the watertightness criteria are met.

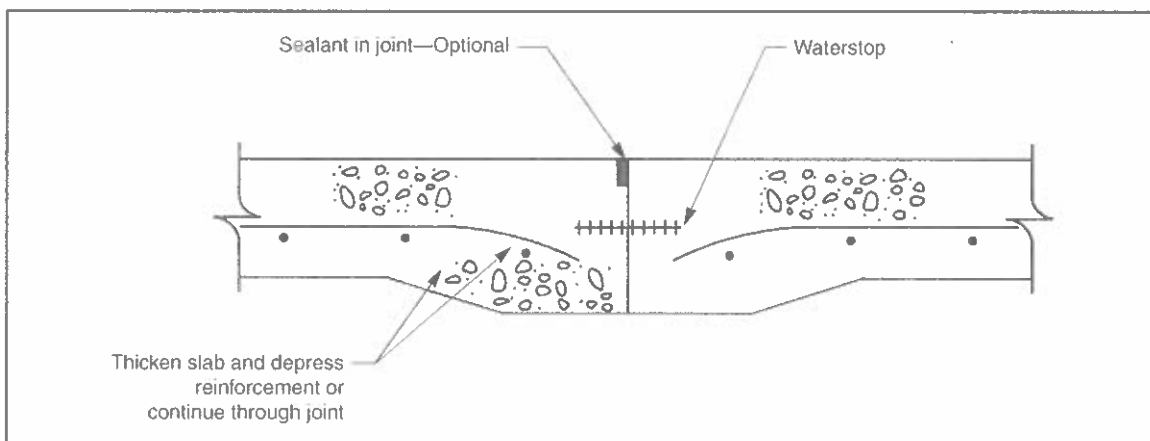

Figure 3 Typical floor-slab construction joint

Subgrade rigidity and uniformity shall be carefully controlled to limit differential vertical movement at joints. Where the wall-base shear is transferred into radial tension in the slab, additional reinforcement shall be provided as required. Expansion joints shall not be used in floors of tanks subjected to a design spectral acceleration at short periods (S_{DS}) of 0.50 or higher, unless special precautions are taken to ensure adequate performance of the joint under vertical and horizontal seismic loadings.

3.8.4 Subsurface investigation and report. The purchaser's representative shall provide a geotechnical report based on an investigation conducted by a geotechnical engineer. The subsurface investigation and report should be according to ACI 372R, appendix A.

3.8.4.1 Subgrade compaction. The subgrade for membrane floors must be of uniform density, stiffness, and compressibility to minimize differential settlement of the floor and footings. Disturbed subgrade or loosely consolidated soil or foundation material shall be removed and replaced with suitable compacted soil, or it shall be compacted in place. Compaction shall achieve a density of at least 95 percent of the maximum laboratory density determined by ASTM D1557 or a density of at least 98 percent of the maximum laboratory density determined by ASTM D698. Field test for measurement of in-place density shall be according to ASTM D1556 or ASTM D6938. Overexcavation and replacement with compacted imported material may be required if foundation soils are unsatisfactory for the imposed loadings or do not provide uniform support.

3.8.4.2 Subgrade design for leakage. The subgrade for all types of floors shall be designed so that leakage through the floor will not cause erosion and settlement in excess of that provided for in the design.

3.8.5 Floor base. Use of a clean, well-compacted granular base with a minimum thickness of 6 in. (150 mm) shall be used for tanks when the natural subgrade does not meet drainage requirements or is difficult to prepare for floor construction. Gradation should be selected to permit free drainage without loss of fines. When suitable base material is not available, the use of geotextile fabrics shall be used. Base material shall be compacted to at least 95 percent of the maximum laboratory density determined by ASTM D1557 or a density of at least 98 percent of the maximum laboratory density determined by ASTM D698. Cohesionless base material shall be compacted to at least 70 percent of relative density. The determination of the maximum and minimum index density for computation of relative density shall be in accordance with ASTM D4253 and ASTM D4254. The

field tests for the measurement of in-place density shall be in conformance with ASTM D1556 or ASTM D6938. Alternatively, if the base layer is 12 in. (300 mm) thick or less, ASTM compaction and density tests may be replaced by compaction performance criteria as follows. The base material shall be placed in lifts not to exceed 6 in. (150 mm). The lifts shall be compacted with a vibratory roller of sufficient capacity for the specific project needs, subject to review and approval by the purchaser's design professional who is knowledgeable in soil mechanics. For each lift, provide a minimum of four passes, two in each direction.

3.8.5.1 *Hydrostatic uplift.* Where site conditions indicate the possibility of hydrostatic uplift of the floor, a structural floor shall be used or adequate drainage of the floor base shall be provided to relieve the hydrostatic pressure and remove the water from the site. Drainage to a manhole or other drainage structure where the flow can be observed and measured is recommended. The receiving structure shall be below the level of the floor slab to guard against surcharge and backflow to the floor base.

Sec. 3.9 Footing Design

3.9.1 *Wall footings.* When separated wall-floor connections are used at the base of the wall, a continuously reinforced concrete footing, either as a thickened floor edge region, an inverted footing, or one separated from the floor, shall be provided to distribute the vertical loads at the base of the wall to the underlying foundation material. A suitable waterstop shall be provided in all such separated wall-base joint connections. Reinforced nonsliding wall-base tanks shall employ a thickened and reinforced floor edge region to distribute wall loads to the foundation. Foundation for membrane floors and footings shall be of uniform compaction and bearing value to support the structure without differential settlement that may damage the structure. Footings and integral floor slab shall be designed to resist the entire radial and tangential shears from the wall. Design of the floor and the footing shall consider the differential stiffness of the soil support and the concrete encasements to be placed under the floor.

3.9.2 *Column footings.* Column footings shall be designed according to ACI 350 and may be an integral part of the membrane floor. Separation of the column footing from the floor requires the use of submerged joints that increase the potential for leakage. Where footings are placed below the floor slab and integral with it, additional reinforcing may be required to control cracking caused by restriction of slab movement due to concrete shrinkage or temperature changes. Inverted footings placed above the slab will avoid this condition but may entrap

sediment and impede normal washdown and cleaning maintenance. Transitions in floor thickness should be gradual and additionally reinforced for flexural stresses and control of shrinkage cracking and leakage.

Sec. 3.10 Columns

Columns shall conform to the requirements of ACI 350.

Sec. 3.11 Tank Appurtenances

This section is intended only to provide guidance to the purchaser's representative and the designer in the functional aspects of appurtenances to be considered in the tank design.

The tank appurtenances and accessories provided shall be according to ANSI and OSHA standards and the special requirements of governing agencies responsible for health and safety in the locality where the tank is to be constructed.

3.11.1 Inlet and outlet piping arrangement. Disinfectant contact time and residual should be considered in the design. Baffles or directional inlets may be required to achieve water quality objectives. This is particularly important for large tanks or where the daily fluctuations in water level do not provide adequate circulation.

3.11.1.1 Valves. The inlet and outlet pipes should be controlled by valves outside the tank that can be closed and secured for tank inspection and maintenance.

3.11.1.2 Outlet piping. The outlet piping should allow water to flow out of the tank with low head loss. This is especially important when the tank is used as suction storage for a pumping station and allowable head loss is limited. The outlet piping will typically penetrate the tank floor slab and pass beneath the perimeter footing. The outlet piping shall be encased in concrete where it passes under the perimeter footing and under the floor. Special detailing shall be provided when differential settlement between the encased outlet piping and the slab is large enough to risk failure of the slab when subjected to fluid pressure load.

Where sediment from residual turbidity may accumulate in the tank during use, a removable silt stop may be placed on the outlet to prevent its entry into the outlet pipe during periods of high draft.

3.11.1.3 Concrete encasement of piping. Concrete encasement of all piping placed under the foundation and/or floor slab is recommended for added corrosion protection and to reduce the potential for leakage of the under tank piping during the useful life of the structure. Concrete encasement also provides a uniform, dense,

stiff backfill around the under tank pipe that eliminates potential problems with inadequate compaction of soil under and around pipes in an excavation. Flexible joints should be provided outside the wall footing to accommodate any movement caused by differential settlement or seismic activity.

3.11.2 *Other tank piping.*

3.11.2.1 **Tank overflow.** The tank overflow system must be designed to pass the maximum filling rate. The overflow weir, flared inlet, or vortex breaker should be sized to pass the design flow at the maximum static water surface permitted in the wall and roof design. The freeboard specified in Sec. 4.10 is measured from the maximum static water surface to the underside of the roof slab or dome roof at its intersection with the inside face of the wall.

The overflow discharge pipe should extend to a point outside the reservoir wall where it can freely discharge without unacceptable consequences. The termination point of the overflow pipe should include a screen, flap valve, or other device to prevent small animals from accessing the tank through the overflow pipe. The discharge point should also include an air gap or other means to prevent contamination between tank and discharge point.

3.11.2.2 **Washdown piping.** A washdown piping system connected to the potable water system with washdown piping and valved hose connection inside the tank or outside adjacent to the tank access ladder may be a desirable design feature for large-diameter tanks. Temporary pumping may be required for effective washdown pressure. Cross connection measures should be considered in the piping. Uniformly sloping the floor from its high point to the drain will facilitate washdown and cleaning.

3.11.2.3 **Tank drain.** A tank drain line, valved outside the tank, is normally provided to dispose of washdown water during inspection and cleaning. The drain line may be taken from the effluent line, if the effluent line starts at the low point in the tank floor. There may be circumstances where an underdrain system is required to prevent hydrostatic uplift under the tank floor when the tank is emptied. If the tank may be subjected to hydrostatic uplift that cannot be relieved by a gravity drain system, an alarm system or automatic means of pumping down the water table to prevent undesired groundwater loads on the tank on drawdown must be provided, or the tank floor must be designed to accommodate the uplift.

3.11.2.4 **Water level monitoring.** Mechanical target systems, pressure transmitter, ultrasonic or other means to monitor the tank's water level may be

provided and calibrated to the depth of water in the tank if level sensing or recording is required by the purchaser's representative.

3.11.2.5 *Water quality sampling.* Sampling pipes of suitable size for monitoring the quality of water in potable water tanks are also desirable features. If connection is through the tank wall, the device should be protected from freezing and unauthorized access, and be watertight.

3.11.3 *Roof opening, hatches, and ventilators.*

3.11.3.1 *Roof opening security.* All roof openings, including personnel and equipment hatches, sampling points, and ventilators should be constructed to prevent leakage into the tank and be locked to resist unauthorized entry and vandalism.

All roof openings should be atop curbs at least 4 in. (100 mm) high. All covers should turn down at least 1½ in. (38 mm) over the curbs or contain a gutter system or vent shroud to carry water away from the roof opening. All frames and covers should be galvanized steel, fiberglass, or aluminum at least ⅜ in. (5 mm) thick. Personnel hatches shall be at least 2½ ft (0.76 m) square and provided with protective handrails conforming to OSHA specifications, if required.

3.11.3.2 *Roof ventilators.* Roof ventilators should be provided to admit air at a flow rate equal to the maximum tank outflow rate at pressure differentials not exceeding 2.0 in. (50 mm) of water column (equivalent to 10 lb/ft² [0.48 kPa] of loading on the roof or dome). The exhaust capacity of the ventilator must be at least equal to the design fill rate of the tank.

Ventilator screens should be protected from vandalism but must be accessible for inspection, screen replacement, and cleaning to remove insects or airborne lint, pollen, or dust.

3.11.4 *Ladders and stairs.* All access ladders shall conform to OSHA requirements. Galvanized or painted steel may be suitable for exterior ladder construction, but more corrosion-resistant structural materials, such as aluminum, stainless steel, and fiberglass-reinforced plastic, are recommended for interior ladder construction. Flat bar stock, pipe, and tubing have been commonly used for ladder stringers. Normal rung spacing is 12 in. (300 mm), and the distance from the floor or landing to the bottom rung of interior ladders should be the same as the rung spacing. If the liquid depth of the tank is 40 ft (12 m) or greater and a wall accessway is not provided, an interior ladder should be considered. If the distance from final grade to the top of the tank wall/roof edge is greater than 30 ft (9 m), an exterior ladder should be considered.

Where exterior ladders are readily accessible, they may be provided with hinged plate covers or other devices, extending far enough above ground to discourage unauthorized climbers. The cover or other device would be unlocked and swung aside for entry by authorized personnel.

Exterior and interior stairs are seldom used; however, if stairs are required by the purchaser's representative, they should be fitted with handrails and landings at intervals specified by OSHA.

3.11.5 *Wall accessways.* When wall accessways in prestressed concrete tank walls are specified, they shall be constructed of stainless steel or galvanized steel. Accessway covers may be hinged and may be equipped with a locking mechanism if needed to resist unauthorized entry and vandalism. A grab bar and interior ladder may be installed at accessway locations. If the liquid depth of the tank is greater than 40 ft (12 m), an interior ladder or wall accessway should be considered.

3.11.6 *Architectural treatments.* Special architectural treatments are frequently used to enhance the appearance of prestressed tanks, including pilasters, brick, or precast facing panels and special finishes applied over the shotcrete cover coat. Care must be exercised in the selection and installation of anchorages and attachments for pilasters and wall facings to isolate them from contact with the prestressed reinforcement and eliminate the potential for corrosion of the reinforcement.

3.11.7 *Baffle walls.* Straight or curved baffle wall configurations may be provided within prestressed tanks to channel water flow for water quality or other reasons. Baffle walls and their supports and connections shall be designed for all dead, seismic, differential hydraulic, or other imposed loads. The overall tank design shall account for any loads imposed by the baffle wall system. Baffle wall materials may include prestressed concrete, cast-in-place concrete, shotcrete, masonry, stainless steel, fiberglass, plastic, or other engineered systems.

3.11.8 *Inner storage walls.* Interior walls may be provided within a prestressed tank for establishing separate and independent storage areas for flexibility in a water system's storage capacity, for the system's hydraulic design requirements, or for redundancy of capacity during maintenance operations. Wire- or strand-wound inner walls shall meet the requirements of this standard. Conventional cast-in-place concrete inner walls shall be in conformance with ACI 350. Interior walls and their supports and connections shall be designed for all gravity, seismic, differential hydraulic, or other imposed loads. The overall tank design shall account for any loads imposed by the interior walls.

SECTION 4: PROVISIONS FOR EARTHQUAKE-INDUCED FORCES

Sec. 4.1 Introduction

4.1.1 *Design method.* The seismic design of wire- or strand-wound, circular, prestressed concrete tanks involves three major phases: Modeling of the tank structure and effective water masses; deriving the earthquake-induced forces (“load”); and designing the structure to ensure that it can resist the computed forces within the allowable stress and displacement limits (“resistance”).

4.1.1.1 *Modeling.* Modeling of the tank structure may be based on the effective-mass method as used in this standard or a more accurate analysis method of seismic design. The effective mass method recognizes that not all mass participates in seismic response. The procedure outlined in Sec. 4.3 is based on this method.

4.1.1.2 *Load-side phase.* The approach for the “load-side” phase used in this standard is defined by the seismic parameters, seismic coefficients, and site characteristics that were in common use from 1991 until 2006. The earthquake design provisions of the International Building Code, 2006, ASCE 7-05, and ACI 350.3-06 exemplify this approach.

4.1.1.3 *Resistance-side phase.* Consistent with the design provisions of Section 3 of this standard, the “resistance-side” phase of Section 4 is based on the allowable stress design.

4.1.2 *Alternative design method.* Depending on the purchaser’s representative’s expressed preference, the designer may base the seismic design of the tank on any other approved national standard subject to the following conditions:

- a. If the strength-design method is used, the impulsive structure coefficient R_I should be divided by 1.4.
- b. The total lateral force, total base overturning moment, and earthquake-induced stresses computed by the alternative design method should not be less than 80 percent of the values obtained using this standard.

Appendix A provides guidelines for adapting the seismic design provisions of this standard to those of the Uniform Building Code, 1997 (UBC 1997).

4.1.3 *Notation.* The notation used in the various equations presented in Section 4 are defined as follows:

A = cross-sectional area of a single strand, in in.² (cm²)

- A_I = horizontal spectral acceleration from a site-specific response spectrum consistent with the impulsive period at 5.0 percent damping, in units of gravitational acceleration, g . (See definition for g below and Sec. 4.3.5)
- A_C = horizontal spectral acceleration from a site-specific response spectrum consistent with the convective period at 0.5 percent damping, in units of gravitational acceleration, g . (See definition for g below and Sec. 4.3.5)
- A_V = vertical spectral acceleration from a site-specific response spectrum consistent with the impulsive period at 5.0 percent damping, in units of gravitational acceleration, g . (See definition for g below and Sec. 4.3.5)
- B = fraction of site horizontal acceleration to be used in vertical acceleration calculation, Sec. 4.5.1.
- C_C = period dependent seismic response convective coefficient, Sec. 4.3.1(6)
- C_I = period dependent seismic response impulsive coefficient, Sec. 4.3.1(3)
- C_L = coefficient defined in Eq 4-14
- C_V = period dependent seismic response coefficient of vertical acceleration, Sec. 4.5.1
- C_W = coefficient, Figure 5
- d = slosh height, in ft (m), Sec. 4.10
- D = inside tank diameter, in ft (m)
- E = modulus of elasticity of cable or strand, in psi (Pa)
- E_c = modulus of elasticity of concrete, in psi (Pa)
- f_{pu} = specified ultimate tensile strength of strand for restraint cable, psi (Pa), Sec. 4.6.3
- F_a = short-period site coefficient (at 0.2-sec period) from ASCE 7-05, Table 11.4-1
- F_p = long-period site coefficient (at 1.0-sec period) from ASCE 7-05, Table 11.4-2
- g = acceleration due to gravity, 32.2 ft/sec² (9.81 m/sec²)
- G = shear modulus of elastomeric pad, in psi (Pa)
- H = maximum depth of water acting on the tank shell, in ft (m)
- H_{soil} = thickness of soil, in ft (m)
- H_T = distance from the center of gravity of roof to the tank floor, in ft (m)
- I = importance factor from Table 2
- k = spring stiffness per unit length of circumference for cable or elastomeric pad, or both, in lb/ft² (N/m²), Sec. 4.3.1(5)

Table 2 Importance factor

| Occupancy Category* | Tank Use | Importance Factor <i>I</i> |
|---------------------|--|----------------------------|
| IV | Tanks that must remain usable to provide emergency service for fire suppression, with slight structural damage and insignificant leakage after an earthquake | 1.50 |
| III | Tanks that must remain usable, but may suffer repairable structural damage, and can be taken out of service, inspected, and repaired at some convenient time after an earthquake | 1.25 |
| I or II | Tanks not listed in categories III or IV | 1.00 |

* See ASCE 7-05 for Occupancy Category description.

- K_p = the factor from Figure 6 for the ratio of inside tank radius to maximum depth of water, r/H
- L_c = length of cable assumed to stretch, taken as sleeve length plus 35 times strand diameter, in in. (mm)
- L_p = length of bearing pad along circumference, in in. (mm), Sec. 4.3.1(5)
- M_C = overturning moment applied to the bottom of tank shell caused by convective forces, in lb-ft (N-m), Sec. 4.3.1(2)
- M_I = overturning moment applied to the bottom of tank shell caused by impulsive forces, in lb-ft (N-m), Sec. 4.3.1(2)
- M_T = combined overturning moment applied to the bottom of tank shell, in lb-ft (N-m), Sec. 4.3.1(2)
- N_C = total equivalent axisymmetric convective circumferential hoop force along entire height of tank, in lb (N), Sec. 4.5.3
- N_I = equivalent axisymmetric impulsive circumferential hoop force along entire height of tank, in lb (N), Sec. 4.5.3
- N_T = combined equivalent axisymmetric circumferential hoop force along entire height of tank, in lb (N), Sec. 4.5.3
- N_V = total hoop force caused by vertical acceleration, in lb (N), Sec. 4.5.3
- P_c = maximum vertical compressive force, in lb/ft (N/m) of shell circumference, Sec. 4.4.5
- P_t = maximum vertical tensile force or the minimum vertical shell compressive force, in lb/ft (N/m) of shell circumference, Sec. 4.4.5
- r = inside radius of tank wall, in ft (m)
- R_C = convective structural response coefficient, from Table 3
- R_I = impulsive structural response coefficient, from Table 3

Table 3 Structural response coefficient for type of tank

| Structure | Structure Coefficient | | |
|---|-----------------------|-------|---------------|
| | R_I | R_C | Ω_ϕ |
| Tanks with a reinforced nonsliding base (Figure 4A) | 2.25 | 1.0 | 2.0 |
| Tanks with an anchored flexible base (Figure 4B) | 3.50 | 1.0 | 2.0 |
| Tanks with an unanchored and uncontained flexible base (Figure 4C)* | 1.5 | 1.0 | 1.5 |

*The unanchored and uncontained flexible joint of Figure 4C has generally proved adequate in locations where $S_{DS} < 0.5$ although it is recommended that adequacy should be investigated for questionable site-specific conditions or importance factors greater than 1.0 (See Tables 2 and 4)

S_I = mapped maximum considered earthquake, 5 percent damped, spectral response acceleration at a period of 1 sec, expressed as a fraction of the acceleration due to gravity, g , from ASCE 7-05, Fig. 22-1 through 22-14.

S_{aM} = maximum considered earthquake, 5 percent damped, spectral response acceleration at a period of T_I or T_V taken from a site-specific acceleration response spectrum.

S_c = spacing between consecutive cable sets, in in. (mm)

S_{cM} = maximum considered earthquake, 0.5 percent damped, spectral response acceleration at a period of T_C taken from a site-specific acceleration response spectrum.

S_{D1} = design spectral acceleration, 5 percent damped, at a period of 1 sec as defined in Sec. 4.3.1, expressed as a fraction of the acceleration due to gravity, g .

S_{DS} = design spectral acceleration, 5 percent damped, at short periods as defined in Sec. 4.3.1, expressed as a fraction of the acceleration due to gravity, g .

S_p = spacing of elastomeric pads, in in. (mm), Sec. 4.3.1(5)

S_S = mapped maximum considered earthquake, 5 percent damped spectral response acceleration at short periods, expressed as a fraction of the acceleration due to gravity g , from ASCE 7-05, Fig. 22-1 through 22-14.

t = thickness of elastomeric pad after precompression caused by dead load, in in. (mm), Sec. 4.3.1(5)

t_b = tank core wall thickness at the base, in in. (mm)

t_w = average tank core wall thickness, in in. (mm)

T_C = natural period of tank in convective mode, in sec, Sec. 4.3.1(6)

- T_I = natural period of tank in impulsive mode, in sec, Sec. 4.3.1(4)
 $T_S = S_{DI} / S_{DS}$, in sec, Section 4.
 T_V = natural period of vibration of vertical liquid motion, in sec, Sec. 4.5.1
 \ddot{u}_V = vertical acceleration, in g, Sec. 4.5.1
 V_C = base shear at the bottom of the tank shell caused by convective force, in lb (N), Sec. 4.3.1(1)
 V_I = base shear at the bottom of the tank shell caused by impulsive forces, in lb (N), Sec. 4.3.1(1)
 V_T = total base shear at the bottom of the tank shell, in lb (N), Sec. 4.3.1(1)
 W_C = weight of effective mass of tank contents that moves with the tank shell in convective mode, in lb (N), Sec. 4.3.1(7)
 W_I = weight of effective mass of tank contents that moves in unison with the tank shell in impulsive mode, in lb (N), Sec. 4.3.1(7)
 W_R = total weight of the tank roof, plus a portion of snow or other roof live load, in lb (N)
 W_S = total weight of the tank wall (shell), in lb (N)
 W_T = the total weight of tank contents, in lb (N), Sec. 4.3.1(7)
 w = width of elastomeric bearing pad in radial direction, in in. (mm)
 w_t = weight of the tank, in lb/ft (N/m) of shell circumference, Sec. 4.4.5
 X_C = height from the bottom of the tank shell to the centroid of W_C , in ft (m), Sec. 4.3.1(8)
 X'_C = height from the bottom of the tank foundation to the centroid of W_C , in ft (m), Sec. 4.9.3
 X_I = height from the bottom of the tank shell to the centroid of W_I , in ft (m), Sec. 4.3.1(8)
 X'_I = height from the bottom of the tank foundation to the centroid of W_I , in ft (m), Sec. 4.9.3
 X_S = height from bottom of tank shell to center of gravity of the tank shell, in ft (m), Sec. 4.3.1(2)
 α = angle of cable or strand with horizontal, in degrees
 β = damping ratio, in percent, Sec. 4.3.3
 γ = unit weight of water, 62.4 lb/ft³ (9,802 N/m³)
 μ = coefficient of friction, Sec. 4.7
 ω_I = circular frequency of the impulsive mode of vibration, in rad/sec, Eq 4-12 and Eq 4-13
 ε = effective mass coefficient, Eq 4-24
 ρ_c = mass density of concrete, 4.66 lb·s²/ft⁴ (2.40 kN·s²/m⁴)

η_c = modification ratio to account for the influence of damping on the spectral amplification, Sec. 4.3.3

Ω_o = overstrength factor as defined in Table 3

Sec. 4.2 Seismic Joint Types

4.2.1 *Wall-base joint types.* For purposes of seismic design, externally wrapped, prestressed concrete water-storage tanks currently in use can be classified into tanks with the following three types of joints between the wall and the foundation:

1. Reinforced nonsliding base. Tanks with a substantially fixed joint between the wall and the foundation (Figure 4A) that are tied to the footing and floor by adequate steel reinforcement.

2. Anchored flexible base. Tanks with an anchored flexible joint between the wall and the foundation. Anchorage is achieved by diagonal-restraint strand cables embedded in the wall and in the footing, as shown in Figure 4B, which resist tangential movements but permit only limited radial movements of the wall.

3. Unanchored and uncontained flexible base. Tanks with an unanchored and uncontained flexible joint between the wall and the foundation; flexibility is achieved by an elastomeric bearing pad (Figure 4C).

NOTE: Tanks with hinged bases or unanchored and containing flexible bases, while used in the past, are no longer used in current practice in wire- and strand-wound tank construction.

4.2.2 *Applicability of base joint types.* Tanks located in seismic locations where $S_{DS} \geq 0.50$ shall use a Sec. 4.2.1, Figure 4A- or Figure 4B-type joint that anchors the wall to the foundation to prevent or restrict wall displacement during a seismic event. The fixed-base joint described in Sec. 4.2.1(1), Figure 4A, has been used in seismic locations where $S_{DS} \geq 0.50$ primarily in tanks of 2.0 mil gal (7.57 ML) capacity or smaller, whereas the radially freed but anchored flexible base joint described in Sec. 4.2.1(2), Figure 4B, has been used in tanks of all sizes. The fixed base is not recommended for tanks larger than 2.0 MG (7.57 ML) in locations where $S_{DS} \geq 0.50$ without full consideration and adequate reinforcement to counteract the base shear and vertical bending moments induced in the wall and its interaction with the footing and floor slab.

4.2.3 *Wall-to-roof joint connection.* Any of the above categories of tanks may have, at the wall-to-roof connection, a joint that is substantially fixed, has flexible or rigid ties, or that has no ties (elastomeric pad only). A joint with an

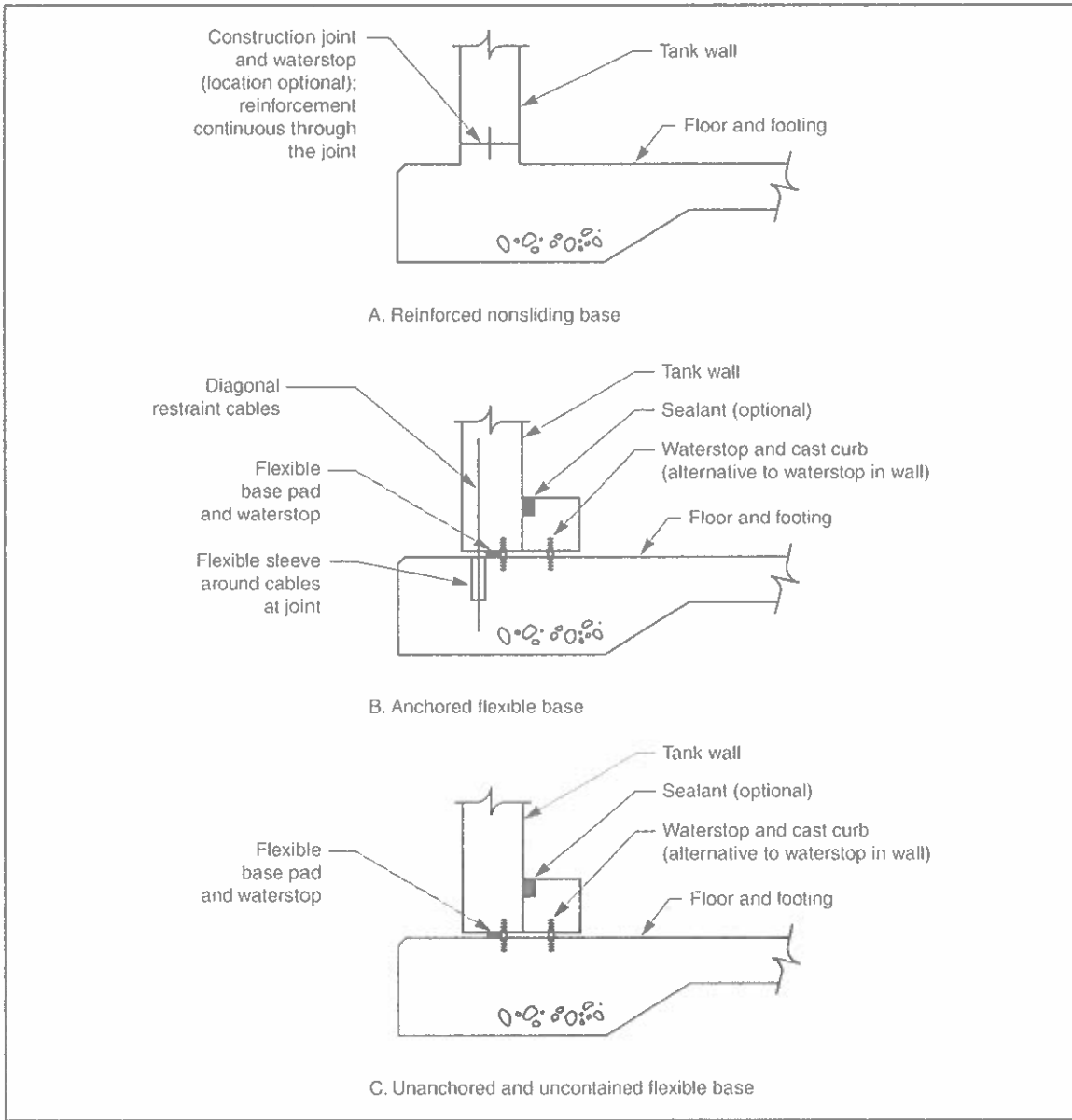

Figure 4 Types of joints used between the wall and its foundation

elastomeric pad and without ties shall be contained to preclude excessive lateral displacement between the roof and the wall. The tank design shall have provisions that prevent the upward displacement of the roof with respect to the wall caused by the height of the sloshing wave and vertical accelerations (see Sec. 4.10).

Sec. 4.3 Seismic Design Loads

4.3.1 *Effective-mass procedure for determining base shear and overturning moment as a result of seismic effects.* The effective-mass procedure considers the fol-

lowing two response modes of the tank and its contents: (1) the impulsive mode, which is the high-frequency amplified response to lateral ground motion of the tank shell and roof together with that portion of the liquid contents that moves in unison with the shell, and (2) the convective mode, which is the low-frequency amplified response of a portion of the liquid contents in the fundamental sloshing mode. The design requires the determination of the hydrodynamic mass associated with each mode and the lateral force and overturning moment applied to the shell resulting from the response of the masses to lateral ground motion. Because the two different response modes are not maximized at the same time, the root mean square can be used for combining forces and moments resulting from the two response modes.

1. The lateral or horizontal base shear caused by seismic forces applied at the bottom of the tank wall shall be determined by Eq 4-1, 4-2, and 4-3.

$$V_I = \frac{IC_I}{1.4 R_I} (\epsilon W_S + W_R + W_I) \quad (\text{Eq 4-1})$$

$$V_C = \frac{IC_C}{R_C} W_C \quad (\text{Eq 4-2})$$

$$V_T = \sqrt{V_I^2 + V_C^2} \quad (\text{Eq 4-3})$$

In the case of a Figure 4A base, the wall design shall provide for 100 percent of the base shear V_T to be transferred tangentially. In addition to providing for 100 percent of the base shear, provide for the maximum radial base shear from the direction of the earthquake, along with the corresponding vertical bending moments and hoop forces, according to Sec. 4.5.3.

In the case of a Figure 4B base with diagonal restraint cables between the footing and the wall, the wall design shall provide for 100 percent of the base shear V_T to be transferred tangentially. In addition, for a Figure 4B base, the maximum hoop forces from the direction of the earthquake shall also be provided for according to Sec. 4.5.3.

2. The overturning moment caused by seismic forces applied at the bottom of the tank wall shall be determined by Eq 4-4, 4-5, and 4-6.

$$M_I = \frac{IC_I}{1.4 R_I} (\epsilon W_S X_S + W_R H_T + W_I X_I) \quad (\text{Eq 4-4})$$

$$M_C = \frac{IC_C}{R_C} W_C X_C \quad (\text{Eq 4-5})$$

$$M_T = \sqrt{M_I^2 + M_C^2} \quad (\text{Eq 4-6})$$

3. The seismic response impulsive coefficient C_I is determined from Eq 4-7 or Eq 4-8.

For $T_I \leq T_S$

$$C_I = S_{DS} \quad (\text{Eq 4-7})$$

For $T_I > T_S$

$$C_I = \frac{S_{DI}}{T_I} \leq S_{DS} \quad (\text{Eq 4-8})$$

Where

$$T_S = \frac{S_{DI}}{S_{DS}} \quad (\text{Eq 4-9})$$

$$S_{DS} = \frac{2}{3} S_S F_a \quad (\text{Eq 4-10})$$

$$S_{DI} = \frac{2}{3} S_1 F_p \quad (\text{Eq 4-11})$$

The notation S_S and S_1 are the mapped spectral response accelerations at short and 1-sec periods, respectively, and shall be obtained from the seismic ground motion maps in Figures 22-1 through 22-14 of ASCE 7-05, chapter 22, and F_a and F_p are the site coefficients and shall be obtained from Tables 11.4-1 and 11.4-2, respectively, of ASCE 7-05, in conjunction with Table 4 of this standard.

4. The tank's natural period T_I may be determined by a rational analysis that considers the weight of the tank wall and roof and the effective weight W_I of the tank contents. For tanks with a nonsliding base (Figure 4A), T_I may be determined from Eq 4-12. For tanks with anchored flexible bases (Figure 4B) and tanks with unanchored and uncontained flexible bases (Figure 4C), T_I may be determined from Eq 4-16 and C_w can be obtained from Figure 5 or by Eq 4-15.

$$T_I = \frac{2\pi}{\omega_I} \leq 0.3 \text{ sec} \quad (\text{Eq 4-12})$$

$$\omega_I = C_L \times \frac{12}{H} \times \sqrt{\frac{E_C}{\rho_c}} \quad (\text{Eq 4-13})$$

$$\omega_I = C_L \times \frac{1}{H} \times \sqrt{\frac{E_C}{1,000\rho_c}} \quad (\text{in SI system})$$

$$C_L = C_W \times 10 \times \sqrt{\frac{t_w}{12r}} \quad (\text{Eq 4-14})$$

Table 4 Soil site class definitions

| Site Class | Soil Profile Name | Average Properties in Top 100 ft | | |
|------------|-------------------------------|---|--------------------------------------|---|
| | | Soil shear wave velocity, V_s (ft/s) | Standard penetration resistance, N | Soil undrained shear strength S_u (psf) |
| A | Hard rock | $V_s > 5,000$ | N/A | N/A |
| B | Rock | $2,500 < V_s \leq 5,000$ | N/A | N/A |
| C | Very dense soil and soft rock | $1,200 < V_s \leq 2,500$ | $N > 50$ | $S_u \geq 2,000$ |
| D | Stiff soil profile | $600 \leq V_s \leq 1,200$ | $15 \leq N \leq 50$ | $1,000 \leq S_u \leq 2,000$ |
| E | Soft soil profile | $V_s < 600$ | $N < 15$ | $S_u < 1,000$ |
| | | Any profile with more than 10 ft of soil having the following characteristics: | | |
| | | <ol style="list-style-type: none"> 1. Plasticity index > 20 2. Moisture content, MC $> 40\%$ 3. Undrained shear strength $S_u < 500$ psf | | |
| F | — | Any profile containing soils having one or more of the following characteristics: | | |
| | | <ol style="list-style-type: none"> 1. Soils vulnerable to potential failure or collapse under seismic loading such as liquefiable soils, quick and highly sensitive clays, collapsible weakly cemented soils. 2. Peats and/or highly organic clays ($H_{soil} > 10$ ft of peat and/or highly organic clay) 3. Very high plasticity ($H_{soil} > 25$ ft with plasticity index PI > 75) 4. Very thick soft/medium stiff clays ($H_{soil} > 120$ ft) | | |

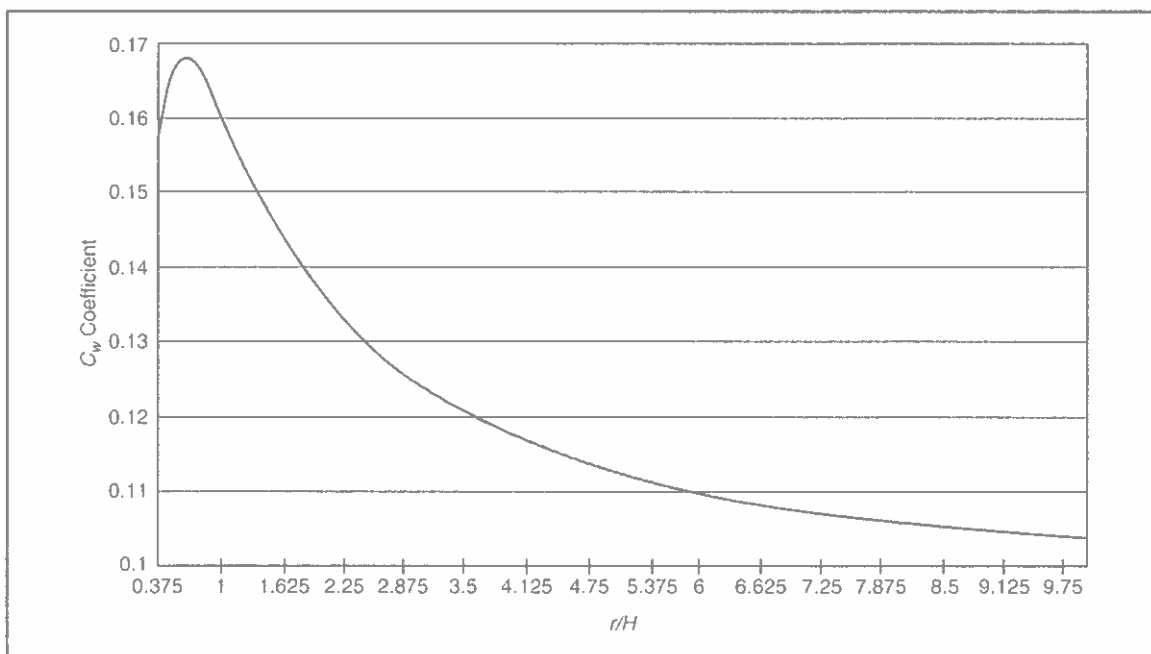

Figure 5 Curve for obtaining factor C_w for the ratio r/H

$$C_L = C_W \times 10 \times \sqrt{\frac{t_w}{1,000r}} \text{ (in SI system)}$$

$$C_W = 9.375 \times 10^{-2} + 0.1020(H/r) - 2.585 \times 10^{-2}(H/r)^2 - 1.566 \times 10^{-2}(H/r)^3 + 7.919 \times 10^{-3}(H/r)^4 - 9.956 \times 10^{-4}(H/r)^5 \quad (\text{Eq 4-15})$$

$$T_l = \sqrt{\frac{4\pi(W_S + W_R + W_l)}{g r k}} \leq 1.25 \text{ sec} \quad (\text{Eq 4-16})$$

5. For tanks with a Figure 4B base, the spring stiffness k is determined from Eq 4-17. In Eq 4-17 and Eq 4-18, for a tank with a continuous bearing pad, the ratio $L_p/S_p = 1.0$. For a tank with a series of bearing pads, for example, having lengths of 6 in. (150 mm) spaced at 12 in. (300 mm) on center, $L_p/S_p = 0.5$.

$$k = 144 \left[\frac{(AE)\cos^2 \alpha}{L_c S_c} + \frac{2GwL_p}{tS_p} \right] \quad (\text{Eq 4-17})$$

$$k = \left[\frac{(AE)\cos^2 \alpha}{L_c S_c} + \frac{2GwL_p}{tS_p} \right] \text{ (in SI system)}$$

For tanks with a Figure 4C base, k is determined from Eq 4-18.

$$k = 144 \frac{2GwL_p}{tS_p} \quad (\text{Eq 4-18})$$

$$k = \frac{2GwL_p}{tS_p} \text{ (in SI System)}$$

NOTE: Eq 4-17 and Eq 4-18 were derived without including the effects of the flexibility of the tank shell and the wall-to-roof connection. These effects may be important under some circumstances.

6. The seismic response convective coefficient C_C is determined from Eq 4-19 or Eq 4-20.

$$\text{For } T_c \leq \frac{1.6}{T_S} \text{ sec}$$

$$C_C = \frac{1.5 S_{D1}}{T_C} \leq 1.5 S_{DS} \quad (\text{Eq 4-19})$$

$$\text{For } T_c > \frac{1.6}{T_S} \text{ sec}$$

$$C_C = \frac{6(0.4)S_{DS}}{T_C^2} = \frac{2.4 S_{DS}}{T_C^2} \quad (\text{Eq 4-20})$$

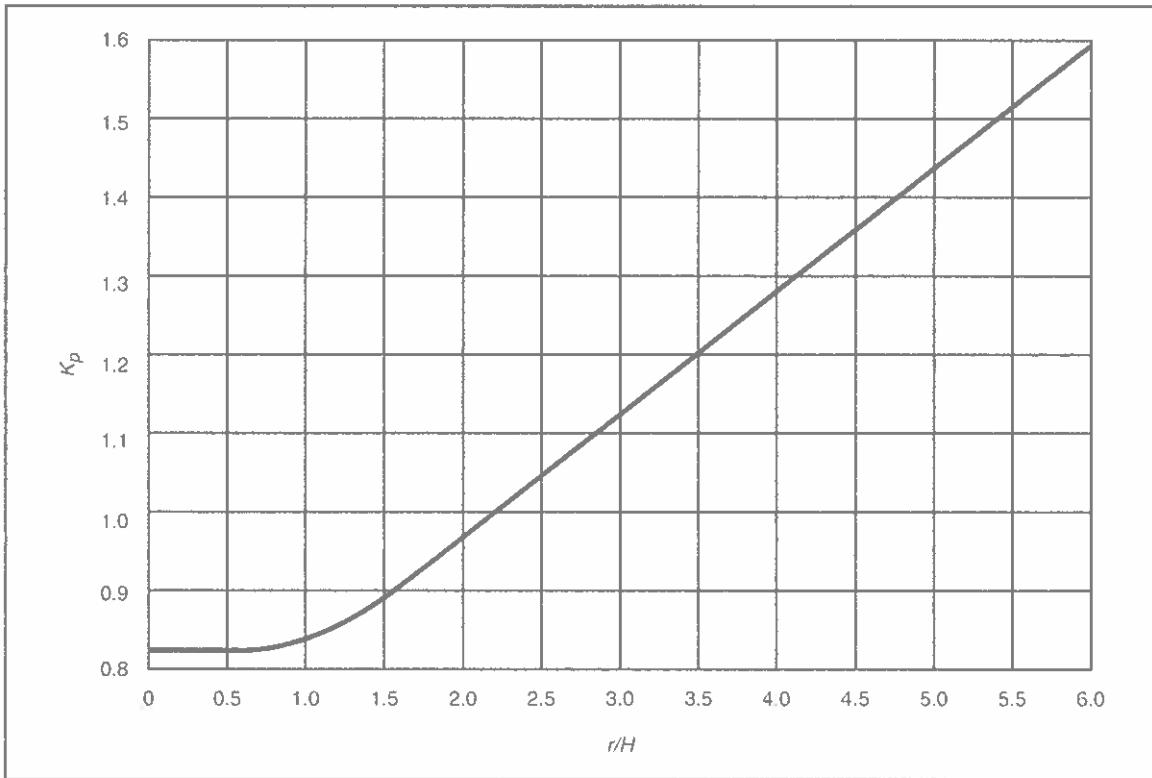

Figure 6 Curve for obtaining factor K_p for the ratio r/H

Factor 1.5 in Eq 4-19 represents the approximate ratio of the spectral amplification based on 0.5 percent damping to that based on 5 percent damping. The value $0.4S_{DS}$ in Eq 4-20 is an approximation of the effective peak ground acceleration (at time $T=0$) reduced by a factor of $\frac{2}{3}$.

The first-mode sloshing wave period T_C is determined from Eq 4-21 or Eq 4-22, and K_p is obtained from Figure 6.

$$T_C = K_p \sqrt{r} \tag{Eq 4-21}$$

$$T_C = K_p \sqrt{\frac{r}{0.3048}} \text{ (in SI system)}$$

or

$$T_C = \sqrt{\frac{r}{1.5 \tanh\left(\sqrt{3.375} \frac{H}{r}\right)}} \tag{Eq 4-22}$$

$$T_C = \sqrt{\frac{r}{1.5(0.3048 \tanh\left(\sqrt{3.375} \frac{H}{r}\right))}} \text{ (in SI system)}$$

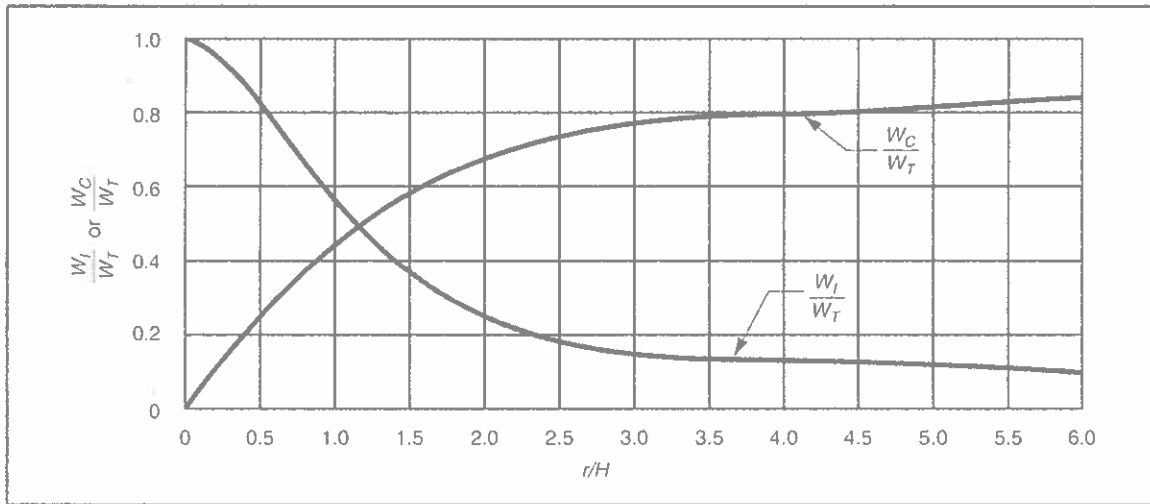

Figure 7 Curves for obtaining factors W_I/W_T and W_C/W_T for the ratio r/H

7. Effective mass of tank contents. The weight of the tank contents that moves in unison with the tank shell in the impulsive mode W_I and the weight of the tank contents that move with the tank wall in the convective mode, W_C , may be determined by multiplying W_T by the ratio W_I/W_T and W_C/W_T , respectively, obtained from Figure 7 for the ratio r/H of the tank, or from Eq 4-25 and Eq 4-26.

The total weight of the tank contents W_T is determined from Eq 4-23. The ratio of the equivalent (or generalized) dynamic mass ϵ of the tank shell to its actual total mass shall be determined from Eq 4-24.

$$W_T = \gamma \pi r^2 H \quad (\text{Eq 4-23})$$

For a Figure 4A base,

$$\epsilon = [0.0151 \left(\frac{D}{H}\right)^2 - 0.1908 \left(\frac{D}{H}\right) + 1.021] \leq 1.0 \quad (\text{Eq 4-24})$$

For a Figure 4B and 4C base, $\epsilon = 1.0$

$$\frac{W_I}{W_T} = \frac{\tanh\left(\sqrt{3}\frac{r}{H}\right)}{\sqrt{3}\frac{r}{H}} \quad (\text{Eq 4-25})$$

$$\frac{W_C}{W_T} = \frac{\sqrt{3.375} r \tanh\left(\sqrt{3.375} H/r\right)}{4H} \quad (\text{Eq 4-26})$$

8. The heights X_I and X_C from the bottom of the tank shell to the centroids of the lateral seismic forces applied to W_I and W_C may be determined by multiplying

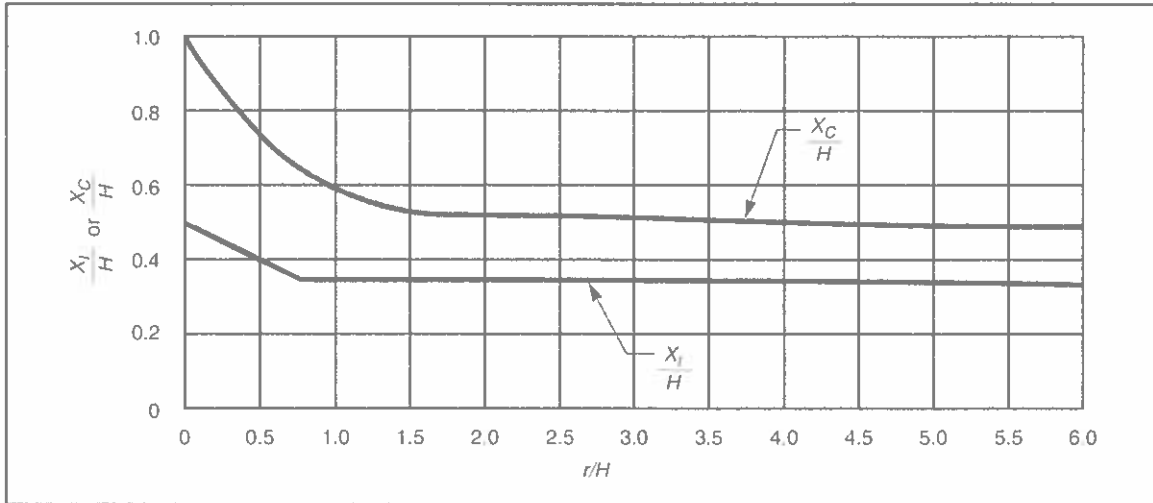

Figure 8 Curves for obtaining factors X_I/H and X_C/H for the ratio r/H

H by the ratios X_I/H and X_C/H , respectively, obtained from Figure 8 for the ratio r/H or from Eq 4-27 and 4-28.

When $r/H \leq 0.6667$, then

$$\frac{X_I}{H} = \left[0.50 - 0.1875 \left(\frac{r}{H} \right) \right] \quad (\text{Eq 4-27})$$

When $r/H > 0.6667$, then

$$\frac{X_I}{H} = 0.375$$

For all values of r/H ,

$$\frac{X_C}{H} = 1 - \left[\frac{\cosh(\sqrt{3.375} H/r) - 1}{(\sqrt{3.375} H/r) \sinh(\sqrt{3.375} H/r)} \right] \quad (\text{Eq 4-28})$$

9. The curves in Figure 6 and Figure 7 are based on equations in chapter 6 and appendix F of *Nuclear Reactors and Earthquakes* (US Nuclear Regulatory Commission 1963). Alternatively, W_I , W_C , X_I , and X_C may be determined by other analytical procedures based on the dynamic characteristics of the tank.

4.3.2 *Application of site-specific response spectrum.* Where site-specific procedures are used, the maximum considered earthquake spectral response accelerations S_{aM} and S_{cM} shall be determined in accordance with Sec. 4.3.5 and shall not be less than the probabilistic maximum earthquake spectral response acceleration as defined in Sec. 4.3.3 and/or the deterministic maximum spectral response accelerations as defined in Sec. 4.3.4.

4.3.3 *Probabilistic maximum considered earthquake.* The probabilistic maximum considered earthquake spectral response acceleration shall be taken as the spectral response acceleration represented by a 5 percent damped acceleration response spectrum having a 2 percent probability of exceedance in a 50-year period (approximately 2,500-year recurrence interval). When the available site-specific response spectrum is for a damping ratio β other than 0.5 percent of critical, the period dependent spectral acceleration S_{cM} given by that spectrum may be modified by the ratio η_c to account for the influence of damping on the spectral amplification as follows.

$$\eta_c = \frac{3.043}{2.73 - 0.45 \ln \beta} \quad (\text{Eq 4-29})$$

4.3.4 *Deterministic maximum considered earthquake.* The deterministic maximum considered earthquake spectral response acceleration at each period shall be taken as 150 percent of the largest median 5 percent damped spectral response acceleration computed at that period for characteristic earthquakes on all known active faults within the region. The deterministic value of the spectral response acceleration shall not be taken lower than $0.6F_v / T_I$ except that the upper limit of the spectral response acceleration shall not exceed $1.5 F_a$. The site coefficients F_a and F_v shall be obtained from ASCE 7-05, Tables 11.4-1 and 11.4-2, respectively.

4.3.5 *Site-specific seismic response coefficients.* When site-specific procedures are used, the maximum considered earthquake spectral response accelerations S_{uM} and S_{cM} shall be obtained from the site-specific acceleration spectrum as follows:

For periods less than or equal to T_S , S_{uM} shall be taken as the spectral acceleration obtained from the site-specific spectra at a period of 0.2 sec, except that it shall not be taken less than 90 percent of the peak spectral acceleration at any period longer than 0.2 sec. For periods greater than T_S , S_{uM} shall be taken as the spectral response acceleration, corresponding to T_I or T_V as applicable. When a 5 percent damped, site-specific vertical response spectrum is available, S_{uM} shall be determined from that spectrum when used to determine A_V .

The designer should also consider increasing the spectral response acceleration at short periods (S_S) and at a period of 1 sec (S_1) in the vicinity of known faults where peak ground accelerations have been observed or may be anticipated to be in excess of those obtained using the maximum considered earthquake procedure and ground motion maps given in ASCE 7-05 (see Sec. 4.3.2).

Coefficients A_I and A_V may be calculated using Eq 4-30 and Eq 4-31, respectively.

$$A_I = \left(\frac{2}{3}\right) S_{aM} \text{ (at period } T_I) \quad (\text{Eq 4-30})$$

$$A_V = \left(\frac{2}{3}\right) S_{aM} \text{ (at period } T_V) \quad (\text{Eq 4-31})$$

The value of S_{cM} shall be taken as 150 percent of the design spectral acceleration corresponding to T_C , except that when a 0.5 percent damped, site-specific horizontal response spectrum is available, S_{cM} shall be equal to the spectral response acceleration from that spectrum corresponding to T_C . If the site-specific response spectrum does not extend into, or is not well defined in the T_C range, coefficient A_C may be calculated using Eq 4-32.

$$A_C = 6 \frac{\left(\frac{2}{3}\right) 0.4 S_{aM}}{T_C^2} = \frac{1.6 S_{aM}}{T_C^2} \quad (\text{Eq 4-32})$$

Therefore, the acceleration of the two masses and its vertical acceleration component shall replace the seismic response coefficients as follows:

The notation A_I , A_C , and A_V replaces C_b , C_C , and C_V providing the following alternative equations.

$$V_I = \frac{IA_I}{1.4 R_I} (\epsilon W_S + W_R + W_I) \quad (\text{Eq 4-1a})$$

$$V_C = \frac{IA_C}{R_C} W_C \quad (\text{Eq 4-2a})$$

$$M_I = \frac{IA_I}{1.4 R_I} (\epsilon W_S X_S + W_R H_T + W_I X_I) \quad (\text{Eq 4-4a})$$

$$M_C = \frac{IA_C}{R_C} (W_C X_C) \quad (\text{Eq 4-5a})$$

$$N_I = \frac{IA_I}{1.4 \pi R_I} (\epsilon W_S + W_R + W_I) \quad (\text{Eq 4-40a})$$

$$N_C = \frac{IA_C}{R_C} (W_C) \left(\frac{8}{9\pi}\right) \quad (\text{Eq 4-41a})$$

$$\ddot{u}_v = \frac{IA_V}{1.4 R_I} \quad (\text{Eq 4-36a})$$

The results obtained by using site-specific response spectra shall not be less than 80 percent by those determined using Eq 4-1, 4-2, 4-4, 4-5, 4-36, 4-40, and 4-41.

Sec. 4.4 Vertical and Horizontal Forces

4.4.1 *Application at joints.* Wall-roof joints and wall-floor joints shall be designed to resist the horizontal and vertical forces they transmit caused by the earthquake and gravity loads acting simultaneously.

4.4.2 *Effects on tank components.* Roofs, walls, and floors shall be investigated for strength and stability under tensile and compressive hoop forces, vertical bending moments, radial or tangential shear forces, and overturning moments resulting from earthquake-induced impulsive and convective forces and from gravity loads acting simultaneously. The impulsive and convective forces shall be converted to their maximum pressure, and this maximum pressure shall be used to analyze the wall as though it were axisymmetric for purposes of finding the maximum hoop forces, radial shears, and vertical bending moments (see Sec. 4.5.3).

4.4.3 *Restraint cables.* For tanks with Figure 4B bases, the strength of restraint cables and their anchorage in the tank wall and foundation shall also be investigated under tensile forces resulting from earthquake-induced base shear and overturning moment.

4.4.4 *Base-pad design considerations.* For tanks with Figure 4B and Figure 4C bases, the strength of base pads shall also be investigated under shear and compressive forces resulting from earthquake-induced base shear, overturning moment, and gravity loads acting simultaneously. The base pads for tanks with Figure 4C bases shall be designed to resist the total earthquake-design base shear. Maximum total base-pad frictional resistance shall not exceed $0.9\mu(W_S + W_R)$, where μ is the coefficient of friction, unless adequate shear keys or other positive mechanical means of attachment are provided to transfer the shear forces from the concrete to the base pads. The 0.9 factor shown on the frictional resistance equation provides a factor of safety against sliding. However, such frictional resistance can be considered only if vertical accelerations have also been calculated and the gravity dead loads reduced by the effects of the vertical accelerations.

4.4.5 *Vertical forces at wall base.* The maximum vertical compressive and tensile forces, P_c and P_t , respectively, at the bottom of the tank wall caused by gravity load and earthquake-induced overturning moment shall be determined from Eq 4-33 and 4-34.

$$P_c = w_t \left[\sqrt{1 + \ddot{u}_v} + 1.273 \frac{M_T}{D^2 w_t} \right] \quad (\text{Eq 4-33})$$

$$P_t = w_t \left[\sqrt{1 + \ddot{u}_v} - 1.273 \frac{M_T}{D^2 w_t} \right] \quad (\text{Eq 4-34})$$

The weight per unit length of shell circumference of the tank, w_t , shall be determined from Eq 4-35.

$$W_t = \frac{W_S + W_R}{\pi D} \quad (\text{Eq 4-35})$$

4.4.6 Cable forces on wall. The maximum vertical compressive force at the bottom of the tank wall caused by gravity load and earthquake-induced base shear in tanks with Figure 4B bases shall include the vertical component of force in the anchor cables.

Sec. 4.5 Other Effects

4.5.1 Vertical acceleration. The tank shall be designed for vertical acceleration. Unless the use of a greater vertical acceleration is specified or agreed on by the purchaser's representative, the vertical acceleration \ddot{u}_v shall be determined from Eq 4-36.

$$\ddot{u}_v = \frac{IC_V}{1.4 R_I} B > 0.2 S_{DS} \quad (\text{Eq 4-36})$$

In the absence of a site-specific response spectrum, the ratio B shall be no less than two thirds ($2/3$) the value of C_V (the seismic response coefficient of vertical acceleration) determined from Eq 4-37 or 4-38.

For $T_V \leq T_s$

$$C_V = S_{DS} \quad (\text{Eq 4-37})$$

For $T_V > T_s$

$$C_V = \frac{S_{D1}}{T_V} < S_{DS} \quad (\text{Eq 4-38})$$

The natural period of the tank T_V may be determined from Eq 4-39 (Luft 1984).*

$$T_V = 2\pi \sqrt{\frac{\gamma DH^2}{24gt_b E_c}} \quad (\text{Eq 4-39})$$

$$T_V = 2\pi \sqrt{\frac{1,000\gamma DH^2}{2gt_b E_c}} \quad (\text{in SI system})$$

* Luft, Rene W. 1984. Vertical Accelerations in Prestressed Concrete Tanks. *Journal of Structural Engineering*, ASCE, 110 (4) 706-714.

4.5.2 *Combining acceleration effects.* The strength and stability of walls, floors, and roofs shall be adequate to withstand the effects of both the design horizontal acceleration and the design vertical acceleration. Effects of maximum horizontal and vertical acceleration shall be combined by the root-sum-square method.

4.5.3 *Equivalent axisymmetric hoop loads.* Hydrodynamic seismic membrane hoop tensile stresses in the circumferential direction; radial shear; and vertical bending moments shall be determined by applying the equivalent axisymmetric hoop loads caused by the response of the mass of the tank roof and shell (wall) combined with the equivalent axisymmetric hoop load as a result of the response of the mass of the tank contents given by Eq 4-40, 4-41, 4-42, and 4-43. The maximum radial force, summed over the full height of the tank wall (see paragraphs further on in this section for the vertical distribution of these forces) for each component, may be obtained by dividing the following equivalent axisymmetrical hoop loads by the radius.

$$N_I = \frac{IC_I}{1.4 \pi R_I} (\epsilon W_S + W_R + W_I) \quad (\text{Eq 4-40})$$

NOTE: The roof weight need not be included in Eq 4-40 for tanks with shear connections between the wall and roof that only transfer forces tangential to the wall. Seismic forces due to the weight of the roof, W_R , should be applied to the wall at a section where roof is in contact with the wall, with due consideration to the type of restraint/joint used. Seismic forces resulting from roof inertia should not be distributed along the full height of the wall.

$$N_C = \frac{IC_C}{R_C} (W_C) \left(\frac{8}{9\pi} \right) \quad (\text{Eq 4-41})$$

$$N_V = \frac{\ddot{u}_v \gamma H^2 r}{2 (1.4)} \quad (\text{Eq 4-42})$$

$$N_T = \sqrt{N_I^2 + N_C^2 + N_V^2} \quad (\text{Eq 4-43})$$

The hoop force per foot (meter) of wall *at any given height* above the tank base for each component shall be computed from the vertical distribution of the respective component loads as explained below.

The vertical distribution of the impulsive hoop loads, resulting from the response of the tank contents, shall be Housner's impulsive pressure distribution,*

* Housner, G.W. 1954. *Earthquake Pressures on Fluid Containers*. Pasadena, Calif.: California Institute of Technology.

or a trapezoid that approximates this distribution, increasing linearly from top to bottom. The centroid of the impulsive hoop-load distribution shall be located at a height from the bottom of the tank shell equal to the centroid X_I of the impulsive portion W_I of the tank contents. The impulsive hoop loads shall not be distributed over a height greater than the depth of the water H .

The vertical distribution of the convective hoop loads, caused by the response of the tank contents, shall be Housner's convective pressure distribution, or a trapezoid that approximates this distribution, decreasing linearly from top to bottom. The centroid of the convective hoop-load distribution shall be located at a height from the bottom of the tank shell equal to the centroid X_C of the convective portion W_C of the tank contents. The convective hoop loads shall not be distributed over a height greater than the depth of water H .

The vertical distribution of the vertical-acceleration hoop loads shall be a triangular distribution with the maximum at the bottom. The vertical-acceleration loads shall not be distributed over a height greater than the depth of the water H .

For purposes of calculating the combined effects on the tank wall and other components, the impulsive, convective, and vertical-acceleration loads shall be combined by taking the square root of the sum of the squares of the three components. When determining the required area of circumferential prestressed reinforcement for a given increment of wall height, the square root of the sum of the squares of the three seismic components shall be taken at the mid-height of the increment and shall be divided by the maximum allowable stress under seismic loading.

Sec. 4.6 Maximum Allowable Stresses and Reinforcement Requirements

4.6.1 *Maximum combined stresses.* Except as provided in Sec. 4.6.3, forces or stresses in the tank caused by the seismic loads given in this section, combined with all or the loads that can act simultaneously, shall not exceed 1.25 times the allowable stresses given in Sec. 3.4.

4.6.2 *Reinforcement for flexural tension.* Whenever seismic effects, combined with other load effects that can act simultaneously, induce flexural tension stresses in the tank wall, bonded nonprestressed vertical reinforcement shall be provided within 1 to 2 in. (25 to 50 mm) of tension faces of the wall. The area of this reinforcement shall be sufficient to resist the entire net flexural tension force. Maximum spacing of bonded reinforcement shall be three times the wall thickness or 12 in. (300 mm), whichever is greater.

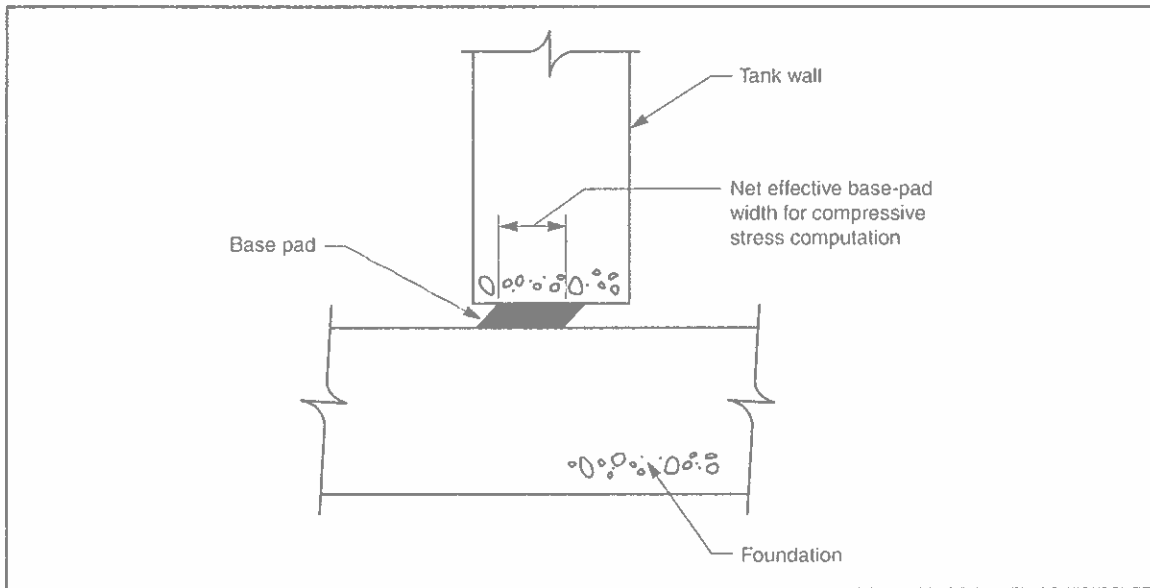

Figure 9 Net effective base-pad width after deformation

4.6.3 *Restraint-cable stress.* Maximum allowable restraint-cable tensile stress shall not exceed $0.75f_{pu}$, where f_{pu} is the specified ultimate tensile strength of the strand. Where allowable stress design methodology is used with the seismic load effect, and the overstrength factor in accordance with ASCE 7-05 Section 15.7.3.a, the allowable stresses in the restraint-cable are permitted to be determined using an allowable stress increase of 1.2.

4.6.4 *Base pad.* Maximum base-pad shear and compressive stresses shall not exceed the limits for occasional loading recommended by the manufacturer. The minimum width-to-thickness ratio for all pads and the minimum length-to-thickness ratio for discontinuous pads shall be 3.0. The net effective pad width after shear deformation (Figure 9) shall be used to compute the maximum compressive stress on the base pad.

Sec. 4.7 Maximum Allowable Coefficient of Friction

The coefficient of friction or base-joint friction μ between concrete and an elastomeric pad shall not exceed 0.5 to compute maximum allowable base-pad frictional resistance under service-loads unless a more precise method of determining the coefficient of friction between the two surfaces is used. Friction between the bearing pad and the wall base shall not be relied on to reduce the tangential displacements of the wall base in locations where $S_{DS} \geq 0.50$.

Sec. 4.8 Additional Requirements

4.8.1 *Uplift limitation.* Tanks without vertical or diagonal ties between the wall and footing shall not be permitted to have tension caused by uplift from earthquake-induced overturning moment when subjected to design seismic load. For no uplift, the overturning moment M_T must be less than or equal to $r(W_S + W_R)$.

4.8.2 *Waterstop integrity.* For tanks with Figure 4B and 4C bases, the relative displacement between the tank shell and the foundation caused by the combined effects of earthquake-induced base shear, gravity loads, and vertical accelerations shall not exceed the capability of the waterstop to accommodate radial and tangential movement without leakage when subjected to design seismic load.

4.8.3 *Restraint-cable sleeves.* For tanks with a Figure 4B base, compressible sponge rubber sleeves shall be used over the restraint cable through the base joint as specified to allow controlled radial wall movement.

4.8.4 *Hydrodynamic hoop forces.* Area of circumferential prestress reinforcement shall be sufficient to prevent hoop tension in the wall due to applied hoop forces.

Sec. 4.9 Foundation Design

4.9.1 *General.* Foundations shall be designed to resist gravity loads and the horizontal and vertical forces caused by seismic forces induced by the design earthquake, acting simultaneously. Foundations for anchored flexible base tanks shall be designed to resist the restraint-cable uplift forces resulting from the earthquake-induced total shear, overturning moment, and gravity loads acting simultaneously. Soil stresses and overall stability against overturning should be checked using the allowable stress design method.

4.9.2 *Soil stress.* A one-third increase in allowable soil stresses is permitted for load combinations that include seismic loads.

4.9.3 *Overturning moment.* The overturning moment in Sec. 4.3.1(2) is that applied to the base of the tank shell. The foundation is subjected to an additional moment caused by the sloshing of the tank contents and the effect of dynamic fluid pressure on the tank bottom. An additional moment equal to the base shear times the vertical distance between the shell base and the resultant of the lateral soil load on the foundation, shall also be taken into consideration.

The overturning moment at the base of the tank, including the tank bottom and supporting structure, shall be determined by Eq 4-44, 4-45, and 4-46.

$$M_I = \frac{IC_I}{1.4 R_I} (\epsilon W_S X_S + W_R H_T + W_I X_I) \quad (\text{Eq 4-44})$$

$$M_C = \frac{IC_C}{R_C} (W_C X_C) \quad (\text{Eq 4-45})$$

$$M_T = \sqrt{M_I^2 + M_C^2} \quad (\text{Eq 4-46})$$

For tanks with $r/H < 0.375$

$$\frac{X_I}{H} = 0.45 \quad (\text{Eq 4-47})$$

For tanks with $r/H \geq 0.375$

$$\frac{X_I}{H} = \frac{\sqrt{3} \left(\frac{r}{H} \right)}{2 \tanh \left[\sqrt{3} \left(\frac{r}{H} \right) \right]} - \frac{1}{8} \quad (\text{Eq 4-48})$$

$$\frac{X'_C}{H} = 1 - \frac{\cosh \left[\sqrt{3.375} \left(\frac{H}{r} \right) \right] - 2.01}{\sqrt{3.375} \left(\frac{H}{r} \right) \times \sinh \left[\sqrt{3.375} \left(\frac{H}{r} \right) \right]} \quad (\text{Eq 4-49})$$

The overall stability of the tank shall be investigated under maximum governing load combinations, including those caused by seismic forces, and the stability against overturning achieved with a safety factor of 1.5 or greater. Under these conditions, the maximum soil stress under the foundation shall not exceed the allowable stress in Sec. 4.9.2. The tank foundation shall be designed for the resulting shear, flexure, and deflection.

4.9.4 Sliding considerations. Tanks shall be designed to resist the effects of sliding because of horizontal forces, including but not limited to unbalanced soil conditions, unbalanced liquid levels, wind, and seismic effects. The required factor of safety against sliding may be adjusted based on risk and probability of loading conditions. The minimum safety factor for sliding shall be 1.5. The minimum safety factor may be reduced to 1.10 for seismic load combinations due to the short-term nature and cyclic response of seismic loads.

Sec. 4.10 Minimum Freeboard

During a seismic event, the maximum water-surface displacement (sloshing height) may impinge on the underside of the roof slab. The anticipated unrestrained sloshing height shall be computed by Eq 4-50 or 4-51. If sufficient freeboard height is not provided to prevent uplift forces caused by sloshing, the tank roof and its connections shall be designed for the uplift forces. The uplift forces generated by

the restraint of sloshing shall be computed as the hydrostatic force produced by the liquid restrained from sloshing. The connection of the roof to the wall shall be designed for the resulting forces, and restraint provided if the uplift sloshing force exceeds 90 percent of the roof dead load on the wall.

$$d = 0.42C_C D \quad (\text{Eq 4-50})$$

but need not exceed Eq 4-51 or the fluid displacement calculation of ASCE 7,

$$d = \frac{3r \coth \left[\sqrt{3.375} \left(\frac{H}{r} \right) \right]}{\frac{6T_C^2}{C_C r} - \sqrt{54}} \quad (\text{Eq 4-51})$$

$$d = \frac{3r \coth \left[\sqrt{3.375} \left(\frac{H}{r} \right) \right]}{\frac{6(0.3048)T_C^2}{C_C r} - \sqrt{54}} \quad (\text{in SI system})$$

Sec. 4.11 Design for Seismic Effects of Backfill

The dynamic seismic forces caused by the backfill surrounding the tank, if any, shall be taken into account according to the soil-structure interaction criteria provided by the geotechnical engineer.

In a buried tank, the dynamic backfill forces shall not be relied on to reduce the dynamic effects of the water in the tank.

SECTION 5: CONSTRUCTION PROCEDURES

Sec. 5.1 Scope

The requirements for placing, finishing, testing, and curing concrete and shotcrete shall be according to the requirements of ACI 301/301M, ACI 302.1R, ACI 304R, ACI 305R, ACI 306R, ACI 308R, ACI 318, ACI 347, ACI 350, ACI 506R, and ACI 506.2, as modified herein, and additional requirements related specifically to wire- and strand-wound, circular, prestressed tank construction not included in these references.

Sec. 5.2 Concrete

5.2.1 Weather limitations.

5.2.1.1 Cold weather placement. Unless specifically authorized by the purchaser's representative in writing, concrete shall not be placed when the

ambient temperature is below 35°F (2°C), even if the temperature is rising, or when the temperature is below 40°F (4°C) and falling. Concrete shall not be placed when the concrete is likely to be subjected to freezing temperature before the concrete compressive strength has reached 500 psi (3.5 MPa). Most well-proportioned concrete will reach this strength when the temperature has been maintained at 50°F (10°C) following the second day after placement. Cold-weather concreting shall be conducted in accordance with ACI 306R and ACI 301/301M. The materials shall be heated so that the temperature of the concrete, when deposited, shall be not less than 50°F (10°C), or as otherwise indicated in ACI 306R, or more than 70°F (21°C). All methods and equipment for heating and for protecting concrete in place shall be subject to review by the purchaser's representative, prior to placement.

5.2.1.2 *Hot-weather concreting.* During hot-weather concreting, cooling of water and aggregate shall be conducted according to the recommendations of ACI 305R.

5.2.1.3 *Placement during drying conditions.* Placement of concrete during periods of low humidity or high winds shall meet the requirements of ACI 301/301M and ACI 305R, particularly when large surface areas are to be finished. In all cases, concrete surfaces exposed to a drying wind shall be covered with polyethylene sheets or other acceptable wet covering systems immediately after finishing. Concrete shall be continuously water cured according to the requirements of ACI 308R, from the time the concrete has taken initial set and for a minimum of 7 days. Water curing by ponding is the recommended method for curing water tank floors and shall be employed whenever practicable.

Curing compounds may be used in conjunction with water curing, provided they are compatible with coatings that may later be applied, or providing they are degradable or will be removed prior to the application of shotcrete or seal coatings. Curing compounds shall not be permitted, under most circumstances, in lieu of water curing, except for vertical surfaces, such as cast-in-place core walls. Curing compounds used on the interior surfaces of tanks shall contain no constituents that will impart taste or odor, or other toxic chemicals to the water.

5.2.2 *Foundation preparation.* All deleterious material shall be removed during excavation for the tank floor and wall and column foundations. Confirm that the subgrade foundation material and its compaction are as specified in Sec. 3.8.4 and Sec. 3.9 for the tank construction. Under no circumstances shall the earth be plowed, scraped, blasted, or dug by machinery in such a way that will result in the

disturbance of material below grade, unless the earthwork specifications require its compaction in place or that it be removed and replaced with compacted imported material.

5.2.3 Floor placement. Check all reinforcing steel immediately prior to placing concrete to verify that the steel is properly positioned, adequately supported, and will have the specified concrete cover. If nonmetallic spacers (e.g., concrete “dobies” or plastic chairs) are used between reinforcing bars and the subbase, verify that they are of adequate size, density, and number. Foot traffic shall not be allowed on the reinforcing steel during the placing of the concrete unless the supports and ties are designed for that purpose. Temporary walkways for concrete placement shall be adequately supported on the base material or formwork.

Concrete-membrane floors shall be cast continuously, without cold joints and, where practicable, without construction or expansion joints. Structural floors shall be cast continuously in sections of such size that once any placement begins, it will be completed without interruption. Waterstops shall be provided in all construction and expansion joints in concrete floor slabs. The horizontal leg of an elastomeric waterstop shall be secured and concreted in a manner that completely encases the waterstop in concrete. Thickening the floor slab at the joint to a minimum of 8 in. (200 mm) will facilitate proper placement of the waterstop. Additional steel reinforcement shall be placed in the floor slab section to minimize crack size due to shrinkage. All top-floor surfaces shall be to the line, grade, and finish specified.

Proper curing of floors is critical to their long-term watertight performance. During hot weather, floors shall be water cured according to the requirements of Sec. 5.2.1.3 and ACI 308R. In the absence of hot weather, water curing according to ACI 308R shall be the preferred curing method, although membrane-forming curing compounds may be used according to ACI 308R where conditions make it impractical to use water curing.

5.2.4 Cast-in-place tank walls and columns. Concrete cast-in-place tank walls and columns shall be placed according to the requirements of ACI 301/301M or ACI 304R. Each vertical segment of the tank wall shall be placed in a single continuous operation without horizontal joints. Unless a high-range water reducer is present in the wall concrete mix, an enriched fine-aggregate mix may be used at the base of columns and the base of the wall to improve embedment of the horizontal base waterstop and the reinforcement and bottom anchorages of vertical prestressing units. Care shall be taken to ensure subsequently placed concrete is vibrated into the enriched mixture.

5.2.4.1 Minimizing concrete segregation. Concrete shall be conveyed from mixer to forms by methods that minimize segregation or loss of ingredients. Concrete shall be deposited as close as practicable to its final position horizontally. Where reinforcing bars or other elements interrupt the placement, and concrete segregation may occur, the free vertical drop of concrete is restricted to no greater than 8 ft (2.4 m), except when starting a wall placement, in which case the free vertical drop of concrete shall not be more than 4 ft (1.2 m). Uninterrupted deposits may be placed by discharging the concrete from the top of the form if there is no cause of segregation, and as approved by the purchaser's representative.

5.2.4.2 Concrete placement. Concrete shall be placed before initial set has occurred and, unless otherwise acceptable to the purchaser's representative, not later than 1½ hr after adding water to the mix when the air temperature is at 85°F (29°C) or above. All concrete shall be placed into the form within this time period. This time period may be extended to a maximum of 2½ hr, provided the purchaser's representative has been previously informed, is satisfied, and agrees that admixtures in sufficient quantity can extend the working time of the concrete without adverse effects on the strength and quality of the concrete. When the air temperature is below 85°F (29°C), the 1½-hr period may be extended by 1 min for each Fahrenheit degree the air temperature is below 85°F (29°C). The time for placement shall not exceed a maximum of 2½ hr after the water has first been added to the aggregate cement mix.

5.2.4.3 Water exclusion. Concrete shall not be placed in water, nor shall water be allowed to rise over freshly placed concrete, until after the concrete has set sufficiently to prevent damage to the mix or finish.

5.2.4.4 Forms and reinforcement. The forms shall be cleaned and coated with an approved nonstaining, nontoxic, bond release form oil before erection as specified in ACI 301/301M. Concrete shall not be placed until all reinforcement is securely and properly fastened in position, the form ties at construction joints have been retightened, and all sleeves, hangers, pipe, bolts, and other items required to be embedded in the concrete have been placed and anchored. Exposed concrete edges, except vertical wall joints, shall have a ¼-in. (19-mm) chamfer.

5.2.4.5 Lifts. Concrete shall be deposited in approximate horizontal layers or lifts not to exceed 24 in. (0.6 m) in depth. Before a new lift is placed, the concrete in the last lift shall be thoroughly and systematically consolidated using a vibrator. The vibrator shall penetrate the upper two lifts and shall be slowly pulled up during each insertion. In other words, each lift before the final lift shall be

vibrated twice. The final lift shall also be vibrated twice. Casting and vibrating of walls may be done through form openings 18 in. by 18 in. (0.46 m by 0.46 m) minimum, located on one side of the wall.

5.2.4.6 *Top finish.* All top surfaces shall be to line and grade and, unless otherwise specified, shall receive a smooth steel-trowel finish.

5.2.4.7 *Wall curing.* Walls shall be cured according to the requirements of ACI 308R.

5.2.4.8 *Defects.* All honeycombed concrete or concrete not meeting the requirements of ACI 301/301M shall be removed to sound concrete and repaired according to ACI 301/301M.

5.2.5 *Construction joints for cast-in-place concrete.*

5.2.5.1 *Layouts and details.* Before the start of construction, the constructor shall submit for review layouts and details of all proposed joints in walls, floors, and footings, unless these details are shown on the contract drawings.

5.2.5.2 *Vertical construction joints.* Spacing of vertical construction joints in concrete walls shall generally not exceed 60 ft (18 m). Shear keys, sleeved dowels, or continuous reinforcement shall be used in the joint to prevent radial displacement of adjacent wall panels or sections prior to prestressing. The face of the vertical joint where the horizontal nonprestressed-steel reinforcement is discontinuous at the joint shall be coated with bond breaker prior to placement of concrete for the adjacent wall section. All vertical construction joints in nondiaphragm tank walls shall have a suitable waterstop in the joint between the water and the prestressing wire or strand. Details of all joints shall be as shown on the drawings. Joints between any two adjacent elements of the floor, wall, flat roof, and wall footing, and between floor and wall or between the wall and its footing, shall contain a suitable waterstop unless otherwise approved by the purchaser's representative. Proposed changes shall be shown on the construction shop drawings submitted for the structure.

5.2.6 *Precast-concrete-panel wall.* For tanks incorporating precast components, concrete for each precast panel shall be placed in one continuous operation.

5.2.7 *Precast-wall-panel erection.* Precast wall panels shall be erected to the correct vertical and circumferential alignment. The edges of adjoining panels shall not vary inwardly or outwardly in the horizontal plane from one another by more than $\frac{3}{8}$ in. (9.5 mm) and shall be placed to the tank radius, within similar tolerance.

5.2.8 *Vertical joints between precast panels.* The edges of the diaphragms of adjoining panels shall be joined or lapped to form a watertight barrier. A steel sheet with lapped joints between diaphragm and steel sheet sealed with an elastomeric or epoxy sealing compound may be used to provide a watertight joint. The lapped joints between diaphragm sheets within each precast panel shall be sealed to secure a watertight joint. The vertical slots between panels shall be filled with cast-in-place concrete, cement–sand mortar, or shotcrete. The strength of the concrete, mortar, or shotcrete shall be equal to that specified for concrete in the wall panels.

5.2.9 *Placement details for concrete in roofs.* Before construction, the constructor shall submit for review the proposed placement details and procedures, including the location and type of construction joints, unless these details and procedures are specified by the purchaser's representative.

Sec. 5.3 Shotcrete

5.3.1 *Weather limitations.*

5.3.1.1 *Placement temperatures.* Placement of shotcrete may start without special protection when the ambient temperature is 35°F (2°C) and rising, and shall be suspended when the ambient temperature is 40°F (4°C) and falling. Placement of shotcrete when the ambient temperature is below 35°F (2°C) and rising, or below 40°F (4°C) and falling, shall be considered cold-weather shotcreting and shall not be allowed unless specifically authorized by the purchaser's representative. Shotcrete shall not be placed on frozen surfaces. Cold-weather shotcreting shall be according to ACI 306R and ACI 301. The temperature of the shotcrete, when deposited, shall be not less than 50°F (10°C).

5.3.1.2 *Hot weather shotcrete.* For shotcrete placed during hot weather, the aggregate shall be cooled by frequent spraying with water in such a manner as to use the cooling effect of evaporation without raising the moisture content above the level suitable for mixing and placement. During such periods, an acceptable placement schedule shall be arranged in a manner that will provide time for the temperature of the previously placed coat to begin to drop. The mixing water shall be the coolest available at the site, insofar as practicable. Hot-weather shotcreting shall be performed according to the requirements of ACI 301/301M and the recommendations of ACI 305R.

5.3.1.3 *Shotcrete placement during dry conditions.* Placement of shotcrete during periods of low humidity or high winds shall meet the requirements of ACI 301/301M and the recommendations of ACI 305R, particularly when large

surface areas are to be placed. Roof domes and wall surfaces exposed to a drying wind shall be water cured continuously according to the requirements of ACI 308R from the time the shotcrete has taken initial set. Curing compounds may be used to assist in curing but shall not be used in lieu of water curing or on surfaces that are to receive an additional shotcrete coating.

5.3.2 *Placing and finishing.*

5.3.2.1 *Severe conditions.* Dense, impermeable shotcrete is required for dome roofs in severe exposure conditions where condensation may occur on the underside of the roof. For this reason, dome roofs of dry-mix shotcrete shall not be used in areas subjected to freeze–thaw conditions. Where shotcrete domes are used, the shell thickness shall be controlled by positive methods, allowing a variation of +½ in. (+13 mm). Dome thickness shall not be less than specified.

Dome joints shall be of the butt type, trimming the edge of that portion of the shotcrete above the mesh or bar reinforcement perpendicular to the form. The portion below shall be as close to perpendicular as practical and all loose material removed before placing the next section of shotcrete. Dome roofs shall be continuously water cured according to the requirements of one of the methods described in ACI 308R.

5.3.2.2 *Shotcrete walls.* Shotcrete walls shall be built up of individual layers of shotcrete no more than 2 in. (50 mm) thick. No less than two coats to a minimum total thickness of 1 in. (25 mm) shall be provided over the diaphragm on the inside of the tank. Under aggressive (corrosive) water conditions, additional protection shall be provided for the diaphragm.

5.3.2.2.1 Before placement of shotcrete, the constructor shall submit, when required by the project documents for the purchaser's representative's review, details of thickness-control procedures and aids. During application of shotcrete coats, the constructor shall demonstrate the effectiveness of the control procedures being used. Shotcrete used to encase reinforcing and diaphragms shall have a slump that will provide full encasement.

5.3.2.2.2 Shotcrete core-wall thickness shall be controlled by the use of positive means such as vertical shooting wires (or line) or edge forms.

5.3.2.2.3 Vertical shooting wires (or line) for manual placement of shotcrete shall be installed under tension and spaced no more than 3 ft (0.9 m) apart to establish uniform and correct wall thicknesses. For machine-applied shotcrete, the shooting wires may be placed farther apart, as demonstrated by consistent and uniform application. Wires of 18- to 20-gauge (0.0475- to 0.0348-in. [1.21- to 0.88-mm])

high-tensile-strength steel or 150-lb (68-kg) test monofilament line shall be used. Shooting wires shall not remain embedded in the shotcrete. Shooting wires shall scribe the contour of the tank core wall from top to bottom and shall not be removed until the cover-coat thickness has been confirmed by the purchaser's representative's agent to be as specified. The specified finish may then be applied.

5.3.2.2.4 Shotcrete finish for the exterior wall surface shall be any of the finishes in Sec. 5.3.3.5, as specified. Shotcrete finish for the inside-core-wall surface shall be smooth and well formed to facilitate cleaning of the tank to reduce future maintenance. An example is natural shotcrete finish followed by light brooming, floating, or troweling to remove pitting and surface roughness.

5.3.3 Shotcrete protection of prestressed wire or strand.

5.3.3.1 Slump and water-soluble chlorides. The primary purpose of the shotcrete wire and cover coats is for protection of the prestressed reinforcement against corrosion, both from the external environment and from materials used in the tank construction. Shotcrete used to encase prestress wire or strand shall have a slump that will provide full encasement of the prestressing wire or strand. Sec. 2.1.2 requires limiting the water-soluble chloride ion content in the concrete or shotcrete covering prestressed wire or strand to 0.06 percent of the weight of the cement in the mix. This requirement shall be adhered to rigidly.

Shotcrete for covering wire or strand shall be tested for water-soluble chloride content according to the requirements of ASTM C1218/C1218M, unless previous test results substantiate that the allowable content will not be exceeded. Testing shall be conducted on either the individual shotcrete ingredients or samples of the hardened shotcrete. Where local aggregates produce a mix that exceeds the 0.06 percent limitation, washing will normally reduce the chloride ion content to within acceptable limits for shotcrete placement; otherwise aggregates shall be imported.

5.3.3.2 Core wall preparation. Before beginning prestressing, voids and other defects on the core wall shall be repaired with an appropriate cementitious or epoxy, approved repair material. Dust, efflorescence, oil, and other foreign material shall be removed from surfaces to be shotcreted. Concrete core walls shall have a bondable surface; attaining this will require abrasive blasting of the outside wall surface before wrapping. Abrasive blasting of concrete shall result in a heavily pitted bondable surface. Prior to wire or strand winding, and again before applying shotcrete cover coats, such materials as dirt, loose sand, and dust shall be removed from the wall surface and wire or strand, and the surface thoroughly dampened.

Hardened shotcrete surfaces shall be prepared by an air–water jet or equivalent method immediately before the next shotcrete coat is applied.

5.3.3.3 Shotcrete encasement of prestressing. Each layer of circumferential prestressing shall be encased in a coat of fine aggregate shotcrete as soon as practical after prestressing. Nozzle distance, velocity, slump, and mix design are critical to satisfactory encasement of prestressing wire or strand.

5.3.3.4 Shotcrete shall be applied with the nozzle held at a small, upward angle, not exceeding 5° from the horizontal plane, and shall be constantly moved in a smooth motion during application, with the nozzle pointing in a radial direction toward the center of the tank. The nozzle distance from the prestressing shall be such that shotcrete does not build up or cover the front face of the wire or strand before the spaces behind and between the prestressing elements are filled. If the nozzle is held back too far, the shotcrete may deposit on the face of the prestressing elements at the same time that it is building on the core wall, thereby creating voids behind the prestressing wire or strand.

5.3.3.4.1 The appearance of a clearly defined pattern of continuous horizontal ridges at the prestressing elements, after they are covered, is an indication of insufficient shotcrete cover or of poor application and probable voids. If this occurs, the application of the wire coat shall be immediately suspended and the work carefully inspected by the purchaser's representative. Corrective measures shall be implemented and completed prior to resuming the shotcreting operations. All improperly deposited shotcrete shall be removed prior to its final set and the shotcreting application procedure corrected. The shotcreting procedure shall be corrected by adjusting the nozzle distance and orientation perpendicular to the wall, or by adjusting the water content of the shotcrete mix. All shotcrete overspray shall be removed from the wall. The shotcreted surface shall be broomed and roughened, if needed, to ensure the proper bond of the subsequent applications. Rebound materials shall be removed from the work and shall not be reused in shotcreting.

5.3.3.4.2 Subsequent layers of circumferential prestressing and shotcrete cover coats shall be applied as soon as the underlying coat has developed sufficient bond and compressive strength to avoid damage.

5.3.3.4.3 Wire/strand coat thickness shall be sufficient to provide a clear cover over the wire or strand of at least ¼ in. (6 mm) and in no case less than the diameter of the wire or strand.

5.3.3.5 Shotcrete covercoat thickness. Shotcrete shall be applied to provide a total thickness of not less than 1 in. (25 mm) over the last layer of wire or strand. The cover coat shall be applied in one or more layers, with the thickness of each layer not exceeding 1 in. (25 mm).

Shotcrete cover coats shall be cut back 1 in. (25 mm) above the top of the footing or floor slab where movement may occur between the wall and floor or footing. Similarly, shotcrete shall be trimmed back from movable joints between the wall and roof. Vertical shooting wires as specified in Sec. 5.3.2.2.3 shall be used to ensure positive control of the thickness.

5.3.3.6 Shotcrete finish. One of the following final shotcrete finishes shall be provided, as specified:

1. Natural gun
2. Broomed
3. Wood float
4. Rubber float

5.3.3.7 Curing. All exposed shotcrete coatings shall be kept moist for at least seven days. Each time a new wire or finish coating is applied, covering an underlying coat, a new seven-day curing period begins for the new coating, superseding the curing schedule on the prior shotcrete coating because its cure will proceed concurrently. Moist curing shall be started as soon as possible without damaging the shotcrete. Curing shall be by fog spraying, or by sprinkling and covering or encapsulating in plastic, so as to keep the surface continuously damp, or by using wetted burlap or cotton mats as specified in ACI 308R. Curing by other means that do not produce the same result shall not be allowed. Curing may only be interrupted for subsequent application of prestressing and shotcreting. Remove any laitance that appears on the shotcrete surface after the curing period by using light sandblasting, air-water blasting, or other methods acceptable to the purchaser's representative.

5.3.4 *Quality control.*

5.3.4.1 Nozzlemen certification. Shotcrete nozzlemen shall be certified according to the applicable requirements of ACI 506R.

5.3.4.2 Control testing. Quality control of shotcrete shall be according to the applicable requirements of ACI 506R.

5.3.5 *Automated application.* In lieu of manually applied shotcrete, shotcrete may be applied by nozzles mounted on power-driven machinery located a

uniform distance from the wall surface, traveling at a uniform speed around the wall circumference to provide the required coatings.

Sec. 5.4 Forming

5.4.1 *General.* Formwork shall meet the requirements of ACI 347 and ACI 301/301M.

5.4.2 *Wall form ties.* Form ties for wood forms shall have waterstops and shall be of the “snap-off breakback” type with conical- or spherical-type inserts $\frac{5}{8}$ in. (16 mm) or more in depth. Flat bar ties used with steel form panels shall have plastic or rubber inserts to form a hole at least 1 in. (25 mm) deep for patching.

As soon as possible after the forms are removed, the tie holes on the interior wall surface shall be packed with nonmetallic, nonshrink, or epoxy–mortar grout as specified in Sec. 2.2.5 and Sec. 2.11.1. The holes on the exterior of the wall shall be dry packed with portland-cement mortar or materials used on the interior wall surface, as specified in Sec. 2.2.3.

Through-bolts used for form ties shall be tapered for ease of removal and patching. If through-bolts are used, the bolts shall be removed and the holes cleaned by sandblasting or wire brushing to remove all grease, bond breaker, or laitance. Bolt holes shall be vinyl plugged and patched with nonshrink or epoxy–mortar grout according to approved details. Equivalent plug products may be used. The outer 1 in. (25 mm) of the hole shall be patched with portland-cement grout or materials used on the interior wall surface that will provide a neutral or alkaline contact with the circumferential prestressing wire and strand.

5.4.3 *Dome-roof forms.* Dome forms shall be designed to resist all forces acting with respect to its sloped surfaces. The bracing required shall be determined by the sequence of concrete or shotcrete placement and the rate at which it is placed. It is important to maintain proper curvature of the shell to avoid flat spots. Except for the outermost set of forms, formwork for concrete or shotcrete domes shall not be removed until the concrete or shotcrete is of sufficient strength and a circumferential prestressing force sufficient to support the dead load and a nominal construction live load has been applied to the dome edge ring.

5.4.4 *Metal diaphragms.* All vertical joints between metal diaphragms shall be sealed to form watertight joints without voids. When the diaphragm performs as a vertical form, it shall be braced and supported in a manner sufficient to eliminate vibrations that would cause sloughing of the shotcrete during application. When it is necessary to penetrate the diaphragm, such as for installation of form ties in type IV core wall tanks, the penetrations shall be covered and sealed

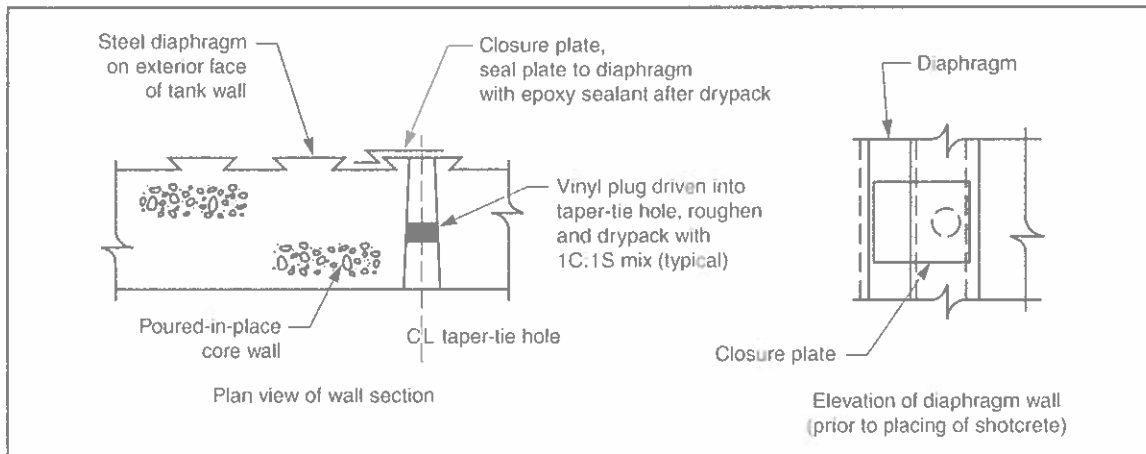

Figure 10 Diaphragm patching detail for type IV tank core wall

with epoxy after removal of the ties and patching of the tie holes. The patching shall result in a watertight barrier that will withstand water pressure the full height of the tank (see Figure 10).

Sec. 5.5 Nonprestressed-Steel Reinforcement and Vertical Tendons

5.5.1 *General.* Steel reinforcement shall be placed according to ACI 301/301M. For those tanks with vertical post-tensioning tendons in the wall, and where the design requires radial movement of the wall with relation to the footing, the post-tensioning units shall be supported prior to concrete or shotcrete placement in such a way that this wall movement will not be restricted. The post-tensioning units shall be supported from the nonprestressed circular reinforcement, from the wall forms, or on plastic or mortar pads placed on the elastomeric bearing pad.

5.5.2 *Concrete and shotcrete cover.* The minimum cover over steel diaphragms, welded-wire fabric reinforcement, and tendon anchorages shall be as specified in Sec. 3.5.6.2.

Sec. 5.6 Prestressing

5.6.1 Circumferential stressing.

5.6.1.1 *General.* The following paragraphs cover the application of high-tensile steel wire or strand, wound under tension by machines, around cylindrical concrete or shotcrete walls, or dome edge rings to place the concrete or shotcrete in compression. An essential feature of this stressing system is the proper application of tension to the prestressed reinforcement as it is placed on the wall.

5.6.1.2 *Handling and storage of wire and strand.* Field handling and storage of prestressing wire and strand shall provide protection from physical damage

and corrosion before, during, and after placement. Such protection shall include enclosed, ventilated, temporary storage facilities where weather conditions warrant. Materials shall be stored off the ground and covered with canvas tarps or other membrane cover that will not permit condensation to form on the steel.

5.6.1.3 Stress consistency. A stressing system shall be used that is capable of consistently producing a stress at any point around the wall, falling within ± 7 percent tolerance of the specified initial stress. Understressed wire or strand shall be compensated for as specified in Sec. 5.6.1.8.

5.6.1.4 Temporary anchorage. Each coil of prestressing wire or strand shall be temporarily anchored at sufficient intervals to minimize the loss of prestress in case a wire or strand breaks during wrapping. Anchor clamps on the outer prestressing wrap shall be removed after application of the wire coat and shall not be permanently buried in the shotcrete cover coats.

5.6.1.5 Coil splices. Ends of individual coils shall be joined by suitable steel-splicing devices capable of developing the full strength of the wire or strand.

5.6.1.6 Minimum concrete or shotcrete strength before prestressing. Stress shall not be applied to either the concrete or shotcrete core wall or dome-roof edge ring by the prestressing operation until they attain a strength of at least 1.8 times the compressive stress being applied.

5.6.1.7 Stress measurement. A calibrated stress-measuring device that can be easily recalibrated shall be used frequently to determine wire or strand stress levels during the wrapping process. At least one stress reading for every coil or a minimum of one per foot of wall height shall be taken immediately after application on the wall, and all such readings shall be on straight lengths of wire or strand. Readings shall refer to the applicable height and layer of wire or strand for which stress is being recorded. A written record of stress readings shall be maintained until all stressing is completed and the cover coats have been applied. The record shall then be delivered to the purchaser's representative. A stress-recording device, which continuously and accurately measures and records the stress as the wire or strand is placed, may be substituted for the previously described method. The recording device shall be calibrated by an independent laboratory before each project.

5.6.1.8 Stress tolerance. If measured wire or strand stress falls below design f_{si} , additional prestress wire or strand shall be applied. If the applied stress of the wire or strand exceeds $1.07f_{si}$, the wrapping operation shall be discontinued immediately on discovery of this condition and satisfactory adjustment made

to the stressing equipment before proceeding. The total prestress force measured on the wall per vertical foot of height shall not be less than the specified force distributed as shown on the force diagram submitted for the structure, nor more than 5 percent greater.

5.6.1.9 Spacing. The force diagram for the tank wall shall be prepared for a minimum clear space between wires or strands on the wall of $\frac{5}{16}$ in. (8 mm) or 1.5 wire or strand diameters, whichever is greater. Any wires or strands not initially meeting the spacing requirements shall be respaced or removed. Wires or strands in areas adjacent to openings or inserts shall be uniformly spaced according to the above. The band of prestressed reinforcement normally required over the height of an opening shall be displaced into circumferential bands immediately above and below the opening to maintain the required total circumferential prestressing force. Banded prestressed reinforcement causes vertical wall-bending effects that shall be taken into account in the design. Prestressing elements shall be placed no closer than 2 in. (50 mm) from the top of the wall or from edges of openings or inserts, nor closer than 3 in. (75 mm) from the base of wall, where radial movement may occur between wall base and floor or footing. Bundling of wires or strands shall be prohibited.

5.6.2 *Vertical wall post-tensioning.*

5.6.2.1 General. The following paragraphs provide recommendations for the post-tensioning of high-tensile strength tendons as vertical prestressed reinforcement in cast-in-place tank walls, or linear prestressing tendons of precast panels through pretensioning or post-tensioning techniques that are not covered by ACI 318.

5.6.2.2 Field handling. All field handling of tendons and associated tensioning and grouting equipment shall be under the direction of an individual with the technical knowledge of prestressing principles, i.e., one who has qualifying experience with the particular system or systems of post-tensioning being used.

5.6.2.3 Protection. Field handling and storage of tendons and component parts on the jobsite shall provide protection against physical damage and corrosion before, during, and after placement. Such protection shall include enclosed, dry, ventilated temporary storage when weather conditions warrant. In no event shall materials be stored on the ground or covered with polyethylene or other membrane cover that will permit condensation to form on the steel.

5.6.2.4 Handling and placement. Tendons shall be handled and placed as follows:

5.6.2.4.1 Generally, tendons or tendon ducts shall be placed on the ground as near as possible to their final positions, then hoisted into their final positions and secured. Neither tendons nor tendon ducts shall be dragged over supporting reinforcement, previously placed tendons, or ducts. A placing sequence shall be developed for the tendon installation, considering supplemental reinforcements that may require the need to thread tendons or ducts through previously placed reinforcing steel. Ducts shall be carefully inspected immediately before concreting to ensure against mortar leakage or indentations that would restrict the free movement of the tensioning steel during the stressing operation. No welding or burning shall be permitted in the vicinity of the prestressing steel, and the prestressed steel shall not be used as an electrical ground.

5.6.2.4.2 The duct sheathing for vertical tendons shall be tied to horizontal reinforcing steel or supported from the formwork to prevent displacement during concrete placement. Vertical tendons supported from the upper terminals require forms of sufficient strength to support their additional weight. Vertical tendon ducts shall be flushed with water immediately after concrete placement to ensure that the lower grout or epoxy injection ports remain unobstructed.

5.6.2.5 Core wall strength. Tendons shall not be stressed until the concrete core wall attains a strength sufficient to sustain the concentration of bearing stresses under the anchorage plates without damage to the wall materials. The permissible compressive stress in the concrete shall be calculated as indicated in the PTFI Post-Tensioning Manual and shall not exceed $1.25f_{ci}'$ at transfer load, nor $1.25f_{ci}'$ at service load. The minimum curing period prior to stressing shall be subject to acceptance by the purchaser's representative.

5.6.2.6 Duct grouting. Grout shall be injected under pressure in vertical tendon ducts from the lower duct terminal. Openings or voids in the anchorages shall be plugged to prevent grout leakage and the ensuing loss of pressure during the grouting operation.

Grout riser tubes or suitable alternative containment shall be attached at the top of vertical tendon ducts to ensure the duct remains full, thus permitting grout settlement to take place in the riser or other containment rather than in the duct. Grout shall be injected into the tendon duct immediately after the tendon has been stressed. When epoxy is used as encasement for the vertical tendons, the application shall be similar and shall be as recommended by the manufacturer.

Sec. 5.7 Wall Tolerances

The maximum out-of-round tolerance for walls shall be based on the ratio of $+1/2$ in., -0 ($+12.7$ mm, -0) per 100-ft (30-m) diameter, and the circumference shall be a smooth curve. Tolerance in wall thickness shall not exceed $+1/2$ in., -0 ($+12.7$ mm, -0). Wall thickness shall not be less than specified. All transitions shall be gradual and smooth. Walls shall be plumb within a tolerance not exceeding $3/8$ in. (9.5 mm) within any 10 ft (3 m) of vertical dimension.

Sec. 5.8 Restraint Cables

5.8.1 *General.* When the tank design requires restraint cables in separated floor-wall connections, the galvanized or epoxy-coated cables (strand) shall be installed between the base of the wall and the footing. Sleeves of sponge rubber or other suitable material shall surround the strands for the specified distance on each side of the joint to permit radial wall movements. Sleeves shall be positively sealed to prevent grout entry.

5.8.2 *Placing.* Cables shall be cut to uniform lengths and pre-bent, if necessary, for proper placement in the footing forms. Care shall be taken in placement to avoid compression of the bearing pad and restraint of radial wall movement. Cable units shall be securely tied to the nonprestressed wall reinforcement to prevent displacement as the concrete or shotcrete is placed.

Sec. 5.9 Waterstops

Waterstops shall be centered in the joints and secured. Concreting shall be performed in a manner that encases all faces of the waterstop. Horizontal waterstops shall be positioned to allow concrete encasement on all sides. Horizontal waterstops shall be secured in a manner that allows them to be lifted up to verify concrete has been consolidated beneath the waterstop, after which the waterstop shall be allowed to return to position and concrete immediately placed over the waterstop. Nails or "hog-ries" driven through the edges of vertical waterstops to facilitate placing and tying shall be permitted. All waterstops shall be spliced by heat welding in a manner that ensures complete continuity as a water barrier.

Sec. 5.10 Elastomeric Bearing Pads

Bearing pads shall be positively positioned prior to wall or roof placement and secured with an approved adhesive to prevent their being uplifted during concrete or shotcrete placement. Pads in cast-in-place concrete walls shall also be held in position by inserting small, dense concrete blocks or plastic shims under vertical reinforcing steel where possible. Nailing of pads shall not be permitted unless the

pads are specifically designed for such anchorage and nailing does not restrict lateral deformation or movement. Where bearing pads are used, the tank wall shall be free of all obstructions that would prevent free radial movement at the joint. The remaining voids between cast-in-place concrete or shotcrete wall and wall footing (or roof) shall be filled with a suitable closed-cell neoprene or rubber filler material and a caulking compound to positively prevent mortar from entering the void.

Sec. 5.11 Sponge Fillers

Sponge fillers for cast-in-place concrete walls shall be 15 percent wider than required to fill the spaces between wall faces, bearing pads, and waterstops. The method of securing sponge-filler pads shall be the same as for elastomeric bearing pads. All voids shall be caulked with a suitable nontoxic sealant that bonds securely to all surfaces of pad, filler, and waterstop. Particular attention shall be paid to the filling and sealing of the joint between the bearing pad and waterstop.

Sec. 5.12 Watertightness

On completion of the tank, the following test shall be applied to determine watertightness by measurement and observation. This shall be done before back-filling.

5.12.1 *Preparation.* Fill the tank with potable water to the overflow level; close all inlet, outlet, and drain valves and ensure they are not passing water (leaking); and let it stand for at least 24 hr.

5.12.2 *Measurement.* Measure the drop in liquid level over the next 72 hr to determine the liquid volume loss for comparison with the allowable leakage. Evaporative losses shall be measured or calculated and deducted from the measured loss to determine the net liquid loss (leakage). The net liquid loss for a period of 24 hr shall not exceed 0.05 percent of the tank capacity.

5.12.2.1 *Extension of test duration.* If the leakage exceeds the maximum allowable, the leakage test shall be extended to a total of five days. If at the end of five days the average 24-hr leakage does not exceed the maximum allowable, the test shall be considered satisfactory. If the net liquid loss exceeds the maximum allowable, leakage shall be considered excessive and the tank shall be repaired, disinfected, and retested until leakage falls within the appropriate limit.

5.12.2.2 *Observation.* Damp spots on the exterior wall surface or measurable leakage of flowing water at the wall base where the source is from inside of the tank shall not be permitted. Damp spots are defined as spots where moisture can be picked up on a dry hand. The source of water movement through the wall

shall be located and permanently sealed in a manner acceptable to the purchaser's representative. Leakage through the wall-base joint or footing shall likewise be corrected. Damp spots and puddles on the footing are generally to be expected and are permissible. Flowing water on the footing is not acceptable and shall be repaired.

Sec. 5.13 Repairs

The constructor shall make all necessary repairs if the tank fails the watertightness test or is otherwise defective. The method of repair shall be subject to acceptance by the purchaser's representative.

5.13.1 *General concrete repair.* The most common repair method for small areas of honeycombed concrete (rock pockets) and other defective concrete is removal and replacement with nonshrink aggregate grout (which may include pea gravel aggregate) bonded to the concrete with an epoxy bonding agent. The minimum strength of material used in the repair shall equal or exceed that specified for the concrete. Defective tie-hole patches shall be removed and the holes repacked or epoxy injected.

5.13.2 *Wall repair.* Damp or wet spots resulting from leakage through the wall shall be repaired with a high-pressure epoxy or urethane injection grouting system or other method acceptable to the purchaser's representative. When epoxy injected grouting is to be performed, a low-viscosity, two-component, water-insensitive, nontoxic epoxy-resin system shall be used. Epoxy shall reach a minimum compressive strength of 6,000 psi (40 MPa) in 24 hr according to the requirements of ASTM D695. An applicator with successful past experience in water-retaining structures shall be present on the job at all times while repairs are being made. Work shall be guaranteed against failure of the epoxy bond in the repair areas for a minimum period of one year following the repair.

Any exposed defect receiving epoxy or urethane repair shall first be cleaned of dirt, laitance, and other material that might prevent proper bonding. A suitable temporary seal shall then be applied to the surface of the defect to prevent the escape of the epoxy or urethane. Entry ports shall be spaced along the seal at intervals not greater than the thickness of the cracked element. The epoxy or urethane shall be injected into the crack at the lowest port first, with sufficient pressure to advance the epoxy or urethane to an adjacent port, using a small nozzle held tightly against the port. The operation shall continue until epoxy or urethane material begins to extrude from the adjacent port. The original port shall be sealed and the injection shall be repeated in one continuous operation until the crack has been injected with epoxy or urethane for its entire length. All ports, including adjacent

locations where epoxy or urethane seepage occurs, shall be sealed as necessary to prevent drips and runouts. On completion of the injection of the crack, the grout shall be allowed to cure for sufficient time to allow the removal of the temporary seal without any draining or running out of the adhesive epoxy or urethane material from the crack. The surface of the epoxy or urethane filled crack shall then be finished flush with the adjacent surfaces and shall show no indentations or evidence of port filling.

5.13.3 *Floor, piping, and valves.* Generally the loss of water through the tank floor, piping, and valves is difficult to determine separately. The total loss shall not exceed the criteria stated in Sec. 5.12.2. If the loss of water exceeds the criteria, the tank floor shall be inspected for point sources of leakage with the tank full or empty.

5.13.4 *Defective areas of the floor allowing water loss shall be repaired.* Defective floor concrete shall be repaired according to Sec. 5.13.1. Floor joints and cracks shall be repaired by epoxy or urethane injection grouting as specified in Sec. 5.13.2, by routing and applying a capillary waterproofing system, by v-grinding the floor crack and filling it with a low-viscosity epoxy, or by other means acceptable to the purchaser's representative.

Sec. 5.14 Tank Backfill

When wall backfill is required, it shall be initiated only after the tank has been satisfactorily tested and filled (see Sec. 6.3), unless another procedure is acceptable to the purchaser's representative. Avoid unbalanced backfill placement caused by a variation in elevation around the tank except as may be fully provided for in the design.

Backfill according to recommendations of a registered design professional. Excavated material may be used for backfilling if suitable. Material shall not include any material greater than 6 in. in size. Backfill material shall be placed in uniform lifts around the periphery of the tank. Compact each lift to a minimum of 90 percent of the maximum laboratory density determined by ASTM D698. Backfill shall be mechanically compacted in 8-in. (200-mm) loose lifts. The field test for measurement of in-place density shall be according to ASTM D1566 or D2922.

If the backfill material is impervious (clay for example), it may be necessary to install a drainage blanket against the wall, such as a layer of gravel or geocomposite drainage fabric.

Sec. 5.15 Cleanup

The premises shall be kept clean and orderly at all times during the work, and, on completion of construction, the constructor shall remove or otherwise dispose of all rubbish and other unsightly material caused by the construction operations. The constructor shall leave the premises in as good a condition as they were found.

Sec. 5.16 Electrical Grounding

Electrical grounding to the nonprestressed reinforcing steel or prestressed reinforcement for any equipment or electrical service shall be strictly prohibited.

Sec. 5.17 Lightning Protection

Lightning protection, if required, shall be a separate system with its own ground connections.

SECTION 6: INSPECTION PROCEDURES

Sec. 6.1 Scope

This section provides procedures for field observation (inspection) of wire- or strand-wound, circular, prestressed concrete water tanks during construction, after construction, and during routine maintenance. ACI SP-2 and the appropriate requirements of ACI 318 and ACI 350 shall be followed unless modified by this standard. The observer is to confirm that materials and construction techniques being used by the tank constructor are those approved by the purchaser's representative. The purchaser's representative's inspection and acceptance of the water tank do not relieve the constructor from compliance with the project's plans and specifications. Some suggestions for maintenance repairs are also included in this section.

Sec. 6.2 Field Observation During Construction

6.2.1 General. The purpose of field observation during construction is to assist the constructor and to verify that the constructor is complying with the plans and specifications. The goal is to ensure that the completed tank is structurally sound, has adequate protection for the nonprestressed steel reinforcement and prestressed steel elements, and is watertight. The construction procedures given in Section 5 are for the guidance of both the constructor and the observer. Section 6 provides additional guidance for field observation of those phases of construction requiring the greatest care to ensure creation of a well-constructed tank. Accurate and detailed records of all phases of construction should be kept and maintained

for documentation and future reference by the purchaser's representative and the constructor.

6.2.2 *Critical items.* Close observation of the following items is essential because of their importance to the corrosion resistance and structural integrity of the tank.

6.2.2.1 *Foundation.* Confirm that the foundation for the tank has been prepared according to the procedures of Sec. 5.2.2. Witness and test all of the underfloor piping for watertightness conforming to the specifications and the placement and compaction of trench backfill and floor base material. Check all formwork and reinforcement for wall and column footings and the reinforcement for tank floor placement.

6.2.2.2 *Materials.* Review tests for all concrete, shotcrete, admixtures, and patching materials for conformance with the specifications and absence of water-soluble ions in excess of the limitations of Sec. 2.2. Verify tolerances on wall form construction and placement of reinforcement.

Verify that all form ties and through-bolts are of the type specified in Sec. 5.4.2.

Observe the placement of concrete and shotcrete of the approved mix proportions, slump, and air entrainment, and observe the steps taken to prevent segregation and achieve dense, impervious tank elements. Verify proper cleaning and patching of wall tie or bolt holes, initiated as soon as possible after removal of formwork and curing of the walls. Witness cleaning and patching procedures using approved materials according to the approved details and manufacturer's instructions.

6.2.2.3 *Waterstops.* Check all waterstop installations prior to concrete placement to verify that they are properly located in the joints, adequately secured, and fused by heat at the splices or joints as specified. Ensure that the horizontal leg of an elastic waterstop is secured in a manner that allows complete encasement in concrete. For horizontal waterstops accessible during concrete casting, verify that the free edge of the waterstop is lifted and the concrete is placed and consolidated underneath the waterstop before any placement over the waterstop. The upper free edge of the vertical waterstop in the floor-to-wall joint should be tied at approximately 12-in. (300-mm) maximum intervals to a securely fastened, horizontal reinforcing bar of size No. 4 or larger or otherwise secured to avoid displacement. It is extremely important that all waterstops are fully embedded in the concrete and that no voids remain.

6.2.2.4 *Pad positioning.* If elastomeric pads are used between the tank wall and floor or footing ring, or between the tank roof and tank wall, see that the

pads are properly positioned and secured before concrete is cast or precast concrete panels are placed. After concrete placement, verify that the wall joint is free of any obstructions that would interfere with radial wall movement.

6.2.2.5 Core wall preparation. Prior to any wire or strand wrapping or shotcreting of the core wall, verify that all voids 1 in. (25 mm) or more in depth, honeycombed concrete, and other defects are completely cut out to solid concrete and dry-packed with mortar. Be sure that all dust, efflorescence, oil, and other foreign material is removed. Verify that the edges of precast panels are in alignment as specified in Sec. 5.2.7 and that all vertical slots between precast wall panels are filled with the specified cement-sand mortar, fine-aggregate concrete, or shotcrete according to the approved details.

6.2.2.6 Vertical prestressing. Make certain that vertical prestressing of the core wall is done prior to circumferential prestressing, but not until the core wall attains the strength specified in Sec. 5.6.2.5.

6.2.2.7 Compressive strength. Verify that circumferential prestressing is not applied until the core wall and the shotcrete or grout in the vertical joints for precast wall sections reach a strength at least 1.8 times the compressive stress being applied. Ensure that wire anchors are not contacting the reinforcing bars by checking the anchor holes before the anchors are inserted. Prestressed wire or strand shall be electrically isolated from all other metallic structural elements. All anchors and clamps used with galvanized wire or strand should be galvanized steel. By direct measurement, verify that minimum wire or strand spacing described in Sec. 5.6.1.9 is maintained. Measure and record wire or strand stress levels during the wrapping process. Confirm that the measuring device is correctly calibrated as described in Sec. 5.6.1.7 and that stress levels are in compliance with the specifications as described in Sec. 5.6.1.8.

6.2.2.8 Shotcrete. Confirm that the shotcrete mix complies with specifications, that the method of application and minimum thickness of the wire coats and cover coats are correct prior to removing of the shooting wires, and that there are no voids behind the wire or strand. See Sec. 5.3.3.

6.2.2.8.1 As the shotcrete wire coat is applied, visually observe the application of the coating to verify that proper encasement of the prestressed elements has been achieved according to Sec. 5.3.3.3. Continuous monitoring of the application is recommended.

6.2.2.8.2 Checking for proper cover-coat and finish-coat thicknesses and bond are two of the most important tasks of field observation. If vertical shooting

wires are installed, ensure they are in the proper position to obtain the specified cover-coat thickness prior to applying the shotcrete. Verify the shooting wire spacing, tension, and distance from the final wire or strand wrap before shotcreting. After the coating has cured, check the surface of the shotcrete finish coat for hollow-sounding or “drummy” spots by tapping with a light hammer or similar tool. Such spots may indicate a lack of bond between coats and may need to be repaired before tank acceptance by the purchaser’s representative. If patching is extensive and an exterior coating is not specified, an additional shotcrete finish coat may be required to achieve an acceptable appearance.

6.2.2.8.3 If an exterior coating is specified to be applied over the shotcrete cover or finish coat, remove all laitance or other foreign material by abrasive blasting, water blasting, or other method acceptable to the purchaser’s representative before applying the coating.

Sec. 6.3 Inspection After Structure Is Constructed

Observe the leakage test to determine the watertightness of the tank, and conduct a visual inspection to verify that all work has been satisfactorily completed and all appurtenances installed according to the plans and specifications.

6.3.1 *Disinfection.* The tank shall be disinfected, prior to checking for leakage, according to the criteria found in ANSI/AWWA C652, unless more rigid standards are mandated by state or local authorities, or by the purchaser’s representative.

6.3.2 *Watertightness.* Testing for watertightness shall be according to Sec. 5.12. The weather must be dry in order to observe leakage. Particular attention shall be given to the ground surface around the tank and at the perimeter drains for evidence of leakage through the floor, the floor–wall connection, or around piping. To verify the source of the water from a suspected leak, it may be necessary to check for chlorine in the water observed outside the tank or through the use of divers within the tank. A knowledgeable diver and use of underwater lights or a remotely operated inspection vehicle will often provide the most efficient means to locate leaks. If a diver is used, ensure the diver is equipped with a wet or dry suit that can be sterilized before entry into the water to protect the treated water from contamination caused by body contact. Sometimes a diver can locate a leak by placing a waterproof membrane or sterile white cotton ball over a suspicious crack or floor joint. The use of an acceptable dye injected by a diver may show a flow direction of a leak. It is recommended that the diver be equipped for underwater photography to display cracks that open only under hydrostatic loading. It is recommended that a safety plan be created for under-

water inspection. Personnel should never be permitted to enter a tank for underwater inspection without carefully planning the safety procedures to be followed, such as guarding or valving off all outlets, providing suitable lighting, and other appropriate protective measures.

6.3.3 *Wall leaks.* Unless the purchaser's representative approves another procedure, the exterior of the wall shall be carefully inspected for any evidence of damp spots prior to placement of any backfill over the wall footing or against the wall and under full head to the overflow level. The location and cause of all visible leakage and damp spots shall be carefully noted and made a matter of record before proceeding with repair.

6.3.4 *Repairs.* All repairs shall be made according to Sec. 5.13. All repair work shall be inspected while in progress and on completion.

Sec. 6.4 Routine Inspections

A wire- or strand-wound prestressed tank should be inspected after the first year of service; at any time that there are visible problems such as leaks, cracks, delaminations, or rust stains; or during routine inspections to occur every 5 to 10 years following the initial inspection. Inspections should be performed by professionals with working knowledge of the design, construction, and maintenance of these tank structures. Each inspection report should include a recommendation to the next scheduled inspection. Inspections should preferably take place during months when tank surfaces are dry and groundwater is at a minimum. At each interval of inspection, the following activities should be included in the assessment:

6.4.1 *Watertightness.* The initial step should consist of a watertightness test in accordance with Sec. 5.12, valving off the tank, verifying the leakage rate by measuring a drop in the water surface, and comparing this assessment with previous tests. If the leakage exceeds the limitations provided in Sec. 5.12.2, further examination should occur and repairs made as necessary. If there is a significant change in the leakage rate from previous tests, and the leakage rate does not exceed the limitations provided in Sec. 5.12, consideration should be given to conducting a further examination.

6.4.2 *General.* Examine exposed areas of the tank structure, both interior and exterior. If the tank is to remain full, interior inspection may require divers and/or remote operated vehicles. Inflatable rafts floated at varied water levels may also be employed. All items (equipment and personnel) entering a filled potable water tank, must be disinfected before entry into the structure. If the entry is into a drained tank, it is recommended to disinfect equipment and personnel entering the

potable water tank to reduce the potential for contamination, and to disinfect the tank before putting it back into service. On completion of these initial inspections, further inspections (Sec. 6.4.7) may need to be performed. See the subsequent sections for further details.

6.4.3 Wall. Physically examine the exterior surface to locate any signs of possible deterioration or corrosion, including damp/moist spots, rust stains, efflorescence, cracks, or leaks. Wide-angle binoculars are helpful in examining those portions of the wall not accessible by ladder or scaffolding. “Sound test” the shotcrete cover coat at areas that show signs of deterioration or evidence of separation or “disbonding” from the core wall as specified in Sec. 6.2.2.8.2. Carefully record the location and severity of these signs of possible trouble. Color photographs or videotape are valuable additions to the written record. Repair all leaks, as described in Sec. 5.13. If the tank has a dome, particular attention should be given to the inspection of the dome ring. The top and base of the wall shall be inspected where accessible. Inspection of the interior wall surfaces should concentrate on the top and bottom of the wall and around any penetrations and joints.

6.4.4 Floor. For aboveground tanks, a visual inspection of the ground surface around the tank may reveal any leakage through the floor, at the floor–wall connection, or at piping. If a subdrain system has been installed under the floor, water flowing from this system can be checked for chlorine content and leakage rate. This is particularly important for buried tanks. Leaking from cracks or joints in the floor or from the floor–wall connection of a buried or partially backfilled tank may only be detected from inside the tank when the tank is full. Divers or remote operated vehicles can sometimes locate these cracks by evidence of silt buildup at small cracks, or by observation of clean lines at the larger cracks. The diver can release an indicator, such as a nontoxic dye or a sterile white cotton ball, at a suspected leak. The indicator verifies the leak if it moves toward the crack or if it appears outside the tank. All leaks should be promptly repaired.

6.4.5 Roof or dome. The interior and exterior of the roof should be physically examined for any signs of rust staining, efflorescence, cracks, spalling, or change in dome curvature or elevation. Monitors, manholes, or other roof penetrations should be inspected for rust, cracks, discontinuity in curvature, or leakage. All spalled areas and cracks in the top surface over $\frac{1}{16}$ in. (1.6 mm) wide, where leakage through the roof may occur, should be repaired. If leakage is evident, cracks should be repaired by injecting with epoxy or urethane as described in Sec. 5.13, by v-grinding the crack and filling it with a low-viscosity epoxy, by using a suitable

nontoxic roof sealant applied to protect the roof reinforcing steel and maintain water quality, or by other means acceptable to the purchaser's representative. Sealant at expansion joints in flat slab roofs should be carefully inspected. If joint leakage or disbonded sealant is observed, the sealant should be removed and replaced.

6.4.6 *Tank appurtenances.* The following appurtenances shall be inspected:

1. Roof vent: Ensure the screen is intact and no obstructions limit airflow through the vent.

2. Roof hatch: Verify the condition of the hatch, its ability for proper use, and the operation of security devices (such as a padlock).

3. Wall manhole: Verify the watertightness of the seal and proper tightening of the bolts.

4. Overflow pipe: Ensure no obstructions exist at the inlet or outlet of the overflow that would restrict flow.

5. Exterior and interior ladders: Verify the anchorage to the wall, the integrity of the rungs, the soundness of the rung attachment to side rails, and the condition of fall-prevention devices.

6. Roof handrails: Verify the anchorage to the roof and the soundness of rails and posts. Further inspection requiring destructive investigation may be warranted; this may include the removal of loose concrete by chipping to determine the full extent of damage. Such areas should be repaired using appropriate concrete repair materials.

6.4.7 *Further inspection.* If the scheduled inspection shows rusting, staining, cracking (other than surface crazing), or evidence of leakage on the exterior of the wall, small areas of shotcrete should be removed at selected locations and the prestressed wire or strand examined for corrosion damage. At least six areas should be selected for inspection of the prestressed reinforcement, based on the location of rust stains, wet areas, and evidence of shotcrete disbonding and cracks or spalling, as well as areas above or below any wall penetrations. Each exposure location should open a minimum area of 8 in. (203 mm) square. If no wire or strand damage is found at any of the six exposures, the shotcrete can be repaired with a dry-pack cement-sand mortar or epoxy grout, and then the other routine maintenance work can proceed. If reinforcement damage is found at one or more exposures, additional exposures should be made until enough information is obtained to determine if the tank has been structurally weakened.

If scheduled inspections find loose or drummy areas on the roof or interior wall surfaces, these areas may warrant further inspection by chipping away loose concrete to determine extent of damaged area. All areas that are exposed shall be repaired using appropriate concrete repair materials.

These further inspections should be performed under the direction of a registered design professional thoroughly familiar with wire- or strand-wound prestressed tanks and their construction. Inspections shall not proceed until all proposed procedures have been documented and approved by the purchaser's representative and shall not commence until all repair capabilities (time and personnel) are in place to enact the necessary repairs following testing. After the engineer's review of this information, a determination should be made as to whether or not additional remedial work is needed.

Sec. 6.5 Safety

Before and during inspections, conform to all local, state, and federal OSHA and safety requirements.

This page intentionally blank.

APPENDIX A

Alternative Method of Analysis Based on UBC 1997

This appendix is for information only and is not a part of ANSI/AWWA D110.

SECTION A.1: INTRODUCTION

Sec. A.1.1 Scope

The purpose of this appendix is to permit a comparison of the provisions of this standard to the seismic provisions of the 1997 edition of the Uniform Building Code (UBC 1997). The differences between UBC 1997 and the seismic provisions as used in this standard are primarily because of differences in the definition of design ground motions and the construction of the corresponding design response spectra as explained below.

Sec. A.1.2 Design Ground Motions

This appendix presents an outline of the methodology to be followed when computing the “loading side” of seismic analysis according to UBC 1997. In this case, the design ground motions are those with a 10 percent probability of exceedance in 50 years.

SECTION A.2: NOTATION

NOTE: All section, table, and figure references are to UBC 1997 except as otherwise indicated.

C_d = seismic coefficient, as stated in Table 16-Q

C_p = seismic coefficient, as stated in Table 16-R

N_p = near-source factor used in the determination of C_p in Seismic Zone 4 related to the proximity of the structure to known faults with magnitudes and slip rates as stated in Tables 16-T and 16-U.

R = Response modification factor, a numerical coefficient representative of the combined effect of the structure’s ductility, energy dissipating capacity, and redundancy, as stated in Table 3 of this standard, and as modified by Sec. 4.1.2 of this standard.

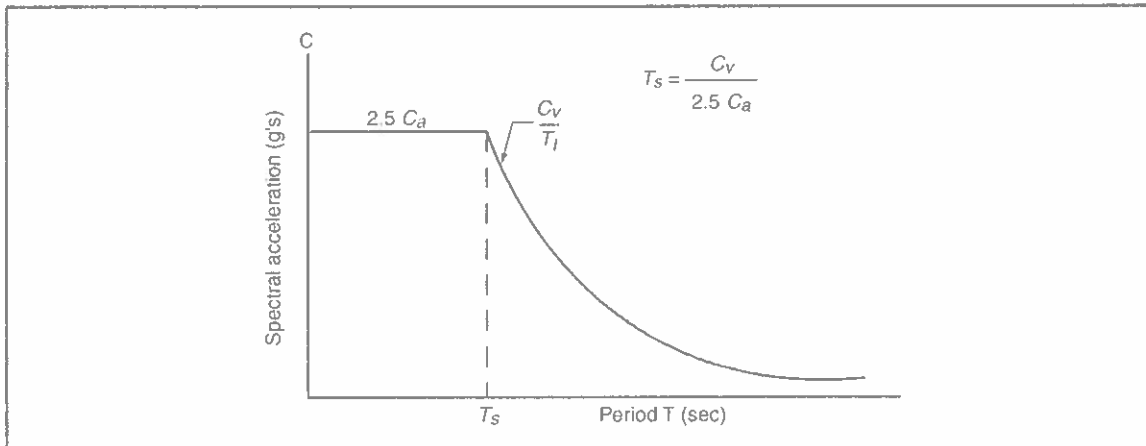

Figure A-1 Adjusted UBC 1997 design response spectrum

- P_w = lateral inertia force of the accelerating wall, W_S ; lb (N)
 P_r = lateral inertia force of the accelerating roof, W_R ; lb (N)
 P_i = total lateral impulsive force associated with W_I ; lb (N)
 P_c = total lateral convective force associated with W_C ; lb (N)
 T_s = $C_v / (2.5 C_a)$, as in Figure A-1 of this appendix

SECTION A.3: LOADING-SIDE, GENERAL METHODOLOGY

1. Select the Seismic Zone (1 through 4) of the site using the seismic zone map, Figure 16-2.
2. Using the Seismic Zone determined in Step 1, find the Zone Factor Z from Table 16-I.
3. Consulting paragraph 1636.2 and Table 16-J, select the soil profile type (designation S_A through S_F) that best represents the soil at the site.
4. Using the Zone Factor Z and the soil profile designation from Steps 2 and 3, find the Seismic Coefficient C_a from Table 16-Q and Seismic Coefficient C_v from the Table 16-R.
5. If the structure is in Seismic Zone 4, select a Seismic Source Type A, B, or C from Table 16-U and Near-Source Factors N_a and N_v from Tables 16-S and 16-T respectively.
6. Compute $T_s^* = C_v / (2.5 C_a) = 0.4 C_v / C_a$.

7. Using the values of C_d , C_p , and T_s , construct a design response spectrum as in Figure 16-3 and below:

$$T_s = C_p / (2.5C_d)$$

8. Compute spectral coefficient C_i and C_c .

8.1. Compute period of vibration T_I according to Eq 4-12 or Eq 4-16 of this standard.

8.2. Compute spectral coefficient C_i corresponding to T_I , using the above design response spectrum as follows:

(a) For Seismic Zones 1, 2, and 3:

For $T_I \leq T_s$

$$C_i = 2.5C_d \quad (\text{Eq A-1})$$

For $T_I > T_s$

$$C_i = C_p / T_I \quad (\text{Eq A-2})$$

(b) For Seismic Zone 4:

$$C_i \geq 0.8ZN_F \quad (\text{Eq A-3})$$

8.3. Coefficient C_c (convective component, $T_C > 1.6 / T_s$). Compute period of vibration T_C using Eq 4-21 of this standard, and

$$C_c = 6 / T_C^2 \quad (\text{Eq A-4})$$

9. Base shear, V :

Compute W_S , W_R , and W_I :

Compute W_I and W_C using the equations in Section 4 of this standard.

Compute coefficient R by selecting coefficient R_I from Table 3 and modify it in accordance with Sec. 4.1.2(a) of this standard.

Select an importance factor, I , from Table 2 of this standard.

Compute the component parts of the total lateral force P_w , P_r , P_i , and P_c as follows:

(a) For all seismic zones:

$$P_w = \frac{C_i I}{R} \varepsilon W_S \quad (\text{Eq A-5})$$

$$P_r = \frac{C_i I}{R} W_R \quad (\text{Eq A-6})$$

$$P_i = \frac{C_i I}{R} W_I \quad (\text{Eq A-7})$$

$$P_c = \frac{C_c I}{R} W_C \quad (\text{Eq A-8})$$

These equations take the following generalized form depending on the period T_I .

For $T_I \leq T_S$

$$P_i = \frac{2.5C_d I}{R} W_I$$

For $T_I > T_S$, (and $T_c > 1.6/T_S$)

$$P_i = \frac{C_i I}{T_I R} W_I \leq 0.11 C_d I W_I \geq \frac{2.5C_d I}{R} W_I$$

and

$$P_c = \frac{6C_d I W_C}{R C T_C^2} \quad (\text{Eq A-9})$$

For $T_c \leq 1.6/T_S$

$$P_c = \frac{1.5C_d I W_C}{R C T_C}$$

(b) In addition for Seismic Zone 4,

$$P_i = \frac{0.8N_v I}{R} W_I$$

10. Total base shear, V :

10.1. The total base shear caused by P_w , P_r , P_i , and P_c may be computed by combining these lateral loads using the square root of the sum of the squares method as in Sec. 4.3.1 of this standard:

$$V = \sqrt{(P_w + P_r + P_i)^2 + P_c^2}$$

10.2. Alternatively, for tanks with period less than 0.06 sec, the total lateral shear V may be computed as follows:

$$V = 0.7C_d I W$$

where $W = W_T + W_S + W_R$

11. Vertical load distribution:

The vertical distribution of the lateral seismic forces may be assumed as given in Sec. 4.5 of this standard.

12. Vertical component of ground motion:

Compute the natural period of vibration of the vertical liquid motion, T_v , according to Sec. 4.5 of this standard.

Compute spectral coefficient C_t , as follows:

(a) For all Seismic Zones:

For $T_v \leq T_S$

$$C_t = C_d \quad (\text{Eq A-10})$$

For $T_v > T_S$

$$C_t = C_d/T_v \quad (\text{Eq A-11})$$

(b) In addition for Seismic Zone 4,

$$C_t \geq 0.8ZN_v \quad (\text{Eq A-12})$$

Compute the spectral acceleration, u_v , as follows:

$$u_v = \frac{C_t IB}{R_I} \quad (\text{Eq A-13})$$

13. Overturning moments:

Compute overturning moments for the lateral loads described above, using the procedures of Sec. 4.9.3 of this standard. Combine the computed moments using the square root of the sum of the squares method as in the same section.

When a site-specific design response spectrum is available, the coefficients C_j and C_f are replaced by the actual spectral values corresponding to T_j and T_f , respectively, from the 5-percent-damped site-specific spectrum; and C_c is replaced by the actual spectral value corresponding to T_c from the 0.5-percent-damped site-specific spectrum.

If the site-specific response spectrum does not extend into, or is not well defined in the T_c range, coefficient C_c shall be calculated using Eq A-5, with C_d representing the effective site-specific peak ground acceleration expressed as the fraction of the acceleration due to gravity, g .

SECTION A.4: RESISTANCE SIDE

The resistance side of the seismic design, including load combinations and strength reduction factors, shall be computed according to the applicable provisions of UBC 1997. Where allowable stress design (working stress design is used), the load combinations shall be calculated according to Sec. 1612.3 of UBC 1997

and the allowable stress values shall be computed according to the applicable provisions of UBC 1997.

SECTION A.5: FREEBOARD

The maximum vertical displacement, d_{max} , of fluid sloshing is expressed by

$$d_{max} = CCI \left(\frac{D}{2} \right) \quad (\text{Eq A-14})$$

This page intentionally blank.

This page intentionally blank.

This page intentionally blank.



**American Water Works
Association**

6666 West Quincy Avenue
Denver, CO 80235-3098
T 800.926.7337
www.awwa.org



1P-2M 44110-2013 (11/13)



Printed on Recycled Paper

ISBN 978-1-58321-980-5



9 781583 219805