

 [Return to Main Menu](#)

 [Return to List of Standards](#)

 [Return to History of Standards](#)



**American Water Works  
Association**

*Dedicated to the World's Most Important Resource®*

**ANSI/AWWA D115-17**  
(Revision of ANSI/AWWA D115-06)

**AWWA Standard**

# Tendon-Prestressed Concrete Water Tanks

AWWA Standards have been used with permission and are copyrighted to the American Water Works Association. All rights reserved.

Effective date: July 1, 2017.

First edition approved by AWWA Board of Directors June 17, 1996.

This edition approved Jan. 14, 2017.

Approved by American National Standards Institute Feb. 17, 2017.



## AWWA Standard

This document is an American Water Works Association (AWWA) standard. It is not a specification. AWWA standards describe minimum requirements and do not contain all of the engineering and administrative information normally contained in specifications. The AWWA standards usually contain options that must be evaluated by the user of the standard. Until each optional feature is specified by the user, the product or service is not fully defined. AWWA publication of a standard does not constitute endorsement of any product or product type, nor does AWWA test, certify, or approve any product. The use of AWWA standards is entirely voluntary. This standard does not supersede or take precedence over or displace any applicable law, regulation, or code of any governmental authority. AWWA standards are intended to represent a consensus of the water industry that the product described will provide satisfactory service. When AWWA revises or withdraws this standard, an official notice of action will be placed on the first page of the Official Notice section of *Journal – American Water Works Association*. The action becomes effective on the first day of the month following the month of *Journal – American Water Works Association* publication of the official notice.

## American National Standard

An American National Standard implies a consensus of those substantially concerned with its scope and provisions. An American National Standard is intended as a guide to aid the manufacturer, the consumer, and the general public. The existence of an American National Standard does not in any respect preclude anyone, whether that person has approved the standard or not, from manufacturing, marketing, purchasing, or using products, processes, or procedures not conforming to the standard. American National Standards are subject to periodic review, and users are cautioned to obtain the latest editions. Producers of goods made in conformity with an American National Standard are encouraged to state on their own responsibility in advertising and promotional materials or on tags or labels that the goods are produced in conformity with particular American National Standards.

**CAUTION NOTICE:** The American National Standards Institute (ANSI) approval date on the front cover of this standard indicates completion of the ANSI approval process. This American National Standard may be revised or withdrawn at any time. ANSI procedures require that action be taken to reaffirm, revise, or withdraw this standard no later than five years from the date of publication. Purchasers of American National Standards may receive current information on all standards by calling or writing the American National Standards Institute, 25 West 43rd Street, Fourth Floor, New York, NY 10036; 212.642.4900; or emailing [info@ansi.org](mailto:info@ansi.org).

*This AWWA content is the product of thousands of hours of work by your fellow water professionals. Revenue from the sales of this AWWA material supports ongoing product development. Unauthorized distribution, either electronic or photocopied, is illegal and hinders AWWA's mission to support the water community.*

ISBN-13, print: 978-1-62576-147-7

eISBN-13, electronic: 978-1-61300-372-5

DOI: <http://dx.doi.org/10.12999/AWWA.D115.17>

---

All rights reserved. No part of this publication may be reproduced or transmitted in any form or by any means, electronic or mechanical, including photocopy, recording, or any information or retrieval system, except in the form of brief excerpts or quotations for review purposes, without the written permission of the publisher.

Copyright © 2017 by American Water Works Association  
Printed in USA

## Committee Personnel

The AWWA Standards Committee on Concrete Water Tanks, Tendon-Type Prestressed, which reviewed and approved this standard, had the following personnel at the time of approval:

Terrence P. Kenyon, *Chair*

### *General Interest Members*

C. Badger, Bates Engineering Inc., Lakewood, Colo.	(AWWA)
R.T. Bates,* Bates Engineering Inc., Lakewood, Colo.	(AWWA)
S.R. Close, Close Associates LLC, Lakewood, Colo.	(AWWA)
T.P. Kenyon, Merrick and Company Inc., Denver, Colo.	(AWWA)
R. Kianoush, Ryerson University, Toronto, Canada	(AWWA)
F.S. Kurtz,† Standards Engineer Liaison, AWWA, Denver, Colo.	(AWWA)
D. Larson,† Standards Council Liaison, St. Louis, Mo.	(AWWA)
W.H. Peffley, Crawford, Murphy & Tilly, Springfield, Ill.	(AWWA)
T.R. Volz, AECOM, Denver, Colo.	(AWWA)

### *Producer Members*

J. Allen, Dutchland Inc., Gap, Pa.	(AWWA)
J. Anderson, VSL/Structural Technologies, Wheat Ridge, Colo.	(AWWA)
D.J. Beiler,* Dutchland Inc., Gap, Pa.	(AWWA)
A.J. Galterio,* VSL/Structural Technologies, Wheat Ridge, Colo.	(AWWA)
T.L. Neff, Post-Tensioning Institute, Farmington Hills, Mich.	(PTI)
B.A. Zavitz, Tindall Corporation, Conley, Ga.	(AWWA)

### *User Members*

D.O. Carroll, Aurora Water, Aurora, Colo.	(AWWA)
M. Garcia, Denver Water, Denver, Colo.	(AWWA)
K.L. Hill, Las Vegas, Nev.	(AWWA)
W.J. Horst, Montgomery County Environmental Services, Moraine, Ohio	(AWWA)
M.L. Wetzel, Town of Ayer Public Works Department, Ayer, Mass.	(AWWA)

---

\* Alternate

† Liaison, nonvoting

This page intentionally blank.

# Contents

*All AWWA standards follow the general format indicated subsequently. Some variations from this format may be found in a particular standard.*

SEC.	PAGE	SEC.	PAGE
<b>Foreword</b>		2.7	Elastomeric Materials ..... 10
I	Introduction ..... vii	2.8	Epoxy Bonding Agent ..... 11
I.A	Background ..... vii	2.9	Shrinkage-Compensating Grout ..... 11
I.B	History ..... vii	2.10	Concrete Coatings ..... 11
I.C	Acceptance ..... viii	2.11	Sealants ..... 12
II	Special Issues ..... ix	<b>3</b>	<b>Design</b>
II.A	General ..... ix	3.1	Notation ..... 12
II.B	Site-Specific Conditions ..... ix	3.2	Design Method ..... 13
II.C	Tendons ..... x	3.3	Design Loads ..... 13
III	Use of This Standard ..... x	3.4	Allowable Stresses ..... 16
III.A	Purchaser Options and Alternatives ..... x	3.5	Footing Design ..... 17
IV	Modification of Standard ..... xii	3.6	Floor Design ..... 18
V	Major Revisions ..... xiii	3.7	Wall Design ..... 20
VI	Comments ..... xiv	3.8	Concrete Roofs ..... 25
		3.9	Dome Roof Design ..... 26
		3.10	Other Roof Designs ..... 30
		3.11	Concrete and Shotcrete Cover ..... 30
		3.12	Additional Considerations in Cold Climates ..... 31
		3.13	Tank Appurtenances ..... 32
		<b>4</b>	<b>Earthquake Design Considerations</b>
<b>1</b>	<b>General</b>	4.1	Introduction ..... 35
1.1	Scope ..... 1	4.2	Seismic-Design Categories ..... 37
1.2	Definitions ..... 1	4.3	Seismic-Design Loads ..... 38
1.3	References ..... 4	4.4	Vertical and Horizontal Forces ..... 39
<b>2</b>	<b>Materials</b>	4.5	Other Effects ..... 40
2.1	Concrete and Shotcrete ..... 7	4.6	Allowable Stresses ..... 41
2.2	Mixing Water ..... 8		
2.3	Admixtures ..... 8		
2.4	Reinforcement ..... 9		
2.5	Ducts ..... 9		
2.6	Sheathing ..... 10		

SEC.	PAGE	SEC.	PAGE		
4.7	Maximum Allowable Coefficient of Friction .....	42	B.2	Observations During Construction .....	65
4.8	Serviceability Requirements.....	42	B.3	Observations After Construction.....	68
4.9	Foundation Design.....	43	B.4	Observations During Routine Maintenance .....	69
4.10	Minimum Freeboard.....	43			
4.11	Design for Seismic Effects of Backfill.....	43	<b>C</b>	<b>Additional Design Considerations</b>	
<b>5</b>	<b>Construction Procedures</b>		C.1	Roof Openings.....	73
5.1	Scope .....	44	C.2	Ladders and Stairs .....	73
5.2	Cast-in-Place Concrete .....	44	C.3	Floors .....	73
5.3	Precast Concrete.....	53	C.4	Sponge-Rubber Fillers .....	74
5.4	Waterstops and Sealants .....	55			
5.5	Elastomeric Bearing Pads and Sponge Fillers .....	56	<i>Figures</i>		
5.6	Tolerances .....	56	1	Typical Floor-Slab Construction Joints.....	19
5.7	Cleaning and Disinfection .....	57	2	Types of Joints Used Between the Wall and Foundation of Concrete Water-Storage Tanks .....	24
5.8	Backfill.....	57	3	(A) Hinged Dome–Wall Connection; (B) Separated Dome–Wall Connection .....	27
5.9	Electrical Grounding.....	57	4	Transfer of Tangential Shear From Wall to Base .....	38
<b>6</b>	<b>Watertightness</b>		5	Net Effective Base-Pad Width After Shear Deformation .....	42
6.1	General .....	58			
6.2	Testing .....	59	<i>Table</i>		
6.3	Repairs .....	59	1	Response Modification Factor, <i>R</i> , for Type of Tank Base .....	36
<b>7</b>	<b>Observations</b> .....	61			
<b>8</b>	<b>Affidavit of Compliance</b> .....	61			
			<i>Appendixes</i>		
<b>A</b>	<b>Bibliography</b> .....	63			
<b>B</b>	<b>Observation Procedures</b>				
B.1	Scope .....	65			

---

# Foreword

*This foreword is for information only and is not part of ANSI/AWWA D115.*

## **I. Introduction.**

I.A. *Background.* The New England Water Works Association (NEWWA) established a committee in 1958 to prepare a standard for the design and construction of circular prestressed-concrete water storage tanks. The committee submitted a suggested specification covering wire-wound prestressed-concrete tanks to NEWWA in October 1962 as a guide to those water utilities that wished to consider the use of these tanks.

The American Concrete Institute (ACI<sup>†</sup>) Committee 344 concluded eight years of committee work with a report titled “Design and Construction of Circular Prestressed Concrete Structures,” published in the *ACI Journal* in September 1970. This report referred to both wire-wound and tendon tanks. After publication of its first report in 1970, ACI Committee 344 could not reach a consensus on a combined report covering both wire-wound and tendon tanks. In 1985 the ACI Committee was divided into two subcommittees and “interim” reports were completed in 1988 for both types of tanks. ACI did not publish these interim reports but made copies available until a consensus could be reached on a recombined report. However, a consensus could not be reached, and in the spring of 1994 ACI Committee 344 was divided into two separate committees, ACI 372 and ACI 373. ACI Committee 373 was disbanded in 2012.

I.B. *History.* In the December 1972 issue of *Journal AWWA*, circular prestressed-concrete water containment structures were discussed in four articles. As a result of these articles and continued discussion on the subject, a standards committee was authorized by the AWWA Standards Council on June 20, 1974, to develop an AWWA standard on circular prestressed-concrete water tanks. The AWWA Standards Committee on Circular Prestressed-Concrete Water Tanks held its first meeting June 19, 1974.

After many meetings and the presentation of many differing viewpoints, this committee decided to defer work on a standard for tendon tanks and to concentrate only on a standard for wire-wound tanks. ANSI/AWWA D110-86, Standard for Wire-Wound Prestressed Concrete Tanks, was published in 1986.

---

\* American National Standards Institute, 25 West 43rd Street, Fourth Floor, New York, NY 10036.

† American Concrete Institute, 38800 Country Club Drive, Farmington Hills, MI 48331.

In 1988 the AWWA Standards Council authorized the formation of a new standards committee to develop a standard for tendon-type prestressed-concrete tanks, with the assigned task of developing a standard for the safe, efficient use of tendon-stressing techniques for design and construction of tanks. Subsequently this new AWWA standards committee was formed and held its first meeting on June 21, 1989, under its first chair, Ib Falk Jorgensen.

The first edition of this standard was published in 1996 and incorporated applicable work of ACI and the AWWA standards committee that had developed ANSI/AWWA D110-86. It contained requirements and recommendations, specifically for potable water containment structures prestressed with bonded circumferential tendons.

The second edition was expanded to include tendon-prestressed tanks of rectangular and other shapes, as well as circular. It was approved by the AWWA Board of Directors on Feb. 12, 2006.

This third edition of ANSI/AWWA D115 was approved on Jan. 14, 2017.

I.C. *Acceptance.* In May 1985, the US Environmental Protection Agency (USEPA) entered into a cooperative agreement with a consortium led by NSF International (NSF) to develop voluntary third-party consensus standards and a certification program for direct and indirect drinking water additives. Other members of the consortium included the Water Research Foundation (formerly AwwaRF) and the Conference of State Health and Environmental Managers (COSHEM). The American Water Works Association (AWWA) and the Association of State Drinking Water Administrators (ASDWA) joined later.

In the United States, authority to regulate products for use in, or in contact with, drinking water rests with individual states.\* Local agencies may choose to impose requirements more stringent than those required by the state. To evaluate the health effects of products and drinking water additives from such products, state and local agencies may use various references, including

1. Specific policies of the state or local agency.
2. Two standards developed under the direction of NSF†: NSF/ANSI 60, Drinking Water Treatment Chemicals—Health Effects, and NSF/ANSI 61, Drinking Water System Components—Health Effects.

---

\* Persons outside the United States should contact the appropriate authority having jurisdiction.

† NSF International, 789 North Dixboro Road, Ann Arbor, MI 48105.



3. Other references, including AWWA standards, *Food Chemicals Codex*, *Water Chemicals Codex*,\* and other standards considered appropriate by the state or local agency.

Various certification organizations may be involved in certifying products in accordance with NSF/ANSI 61. Individual states or local agencies have authority to accept or accredit certification organizations within their jurisdictions. Accreditation of certification organizations may vary from jurisdiction to jurisdiction.

Annex A, “Toxicology Review and Evaluation Procedures,” to NSF/ANSI 61 does not stipulate a maximum allowable level (MAL) of a contaminant for substances not regulated by a USEPA final maximum contaminant level (MCL). The MALs of an unspecified list of “unregulated contaminants” are based on toxicity testing guidelines (noncarcinogens) and risk characterization methodology (carcinogens). Use of Annex A procedures may not always be identical, depending on the certifier.

ANSI/AWWA D115 does not address all material requirements. Users of this standard should consult the appropriate state or local agency having jurisdiction in order to

1. Determine materials requirements, including applicable standards.
2. Determine the status of certifications by parties offering to certify products for contact with, or treatment of, drinking water.
3. Determine current information on product certification.

## **II. Special Issues.**

**II.A. General.** This standard reflects a committee consensus of industry practice concerning the design, detailing, and construction of prestressed-concrete water tanks that employ horizontal prestressing tendons in walls. This standard also addresses the use of prestressing tendons in floors, vertically in the walls, and in roofs. Recommended criteria and guidelines are presented to assist engineers in design and construction of both cast-in-place and precast concrete tanks using tendon prestressing, based on the specific detailed experience of the committee members. Engineering principles are tied to existing codes where applicable. Design and construction of prestressed-concrete water tanks are complex, requiring a wide range of special knowledge and experience. This standard represents a sharing of information on the unique aspects of analysis and construction that are encountered in these types of structures.

**II.B. Site-Specific Conditions.** Because of the wide range of site-specific environments, foundation conditions, loadings, and construction conditions

---

\* Both publications available from National Academy of Sciences, 500 Fifth Street, NW, Washington, DC 20001.

throughout North America, this standard should not be expected to apply universally or to produce a cost-effective and maintenance-free structure in every situation. In adapting this standard to obtain the structure's expected service life for the actual conditions that are anticipated, the purchaser and the designer of the tank are advised to carefully study factors affecting the structure.

II.C. *Tendons.* There are three types of tendons used in the floors, walls, and roofs of tendon-prestressed concrete tanks: bonded, unbonded, and precast-pretensioned. Triple corrosion protection is provided for both bonded and unbonded tendons: (1) two-way prestressed-concrete cover, (2) waterproof plastic ducts or sheathing, and (3) rich cement grout or post-tensioning coating material with corrosion-inhibiting additives. The owner should rely on the engineer-of-record to determine the appropriate type of tendon, taking into account the design requirements and local conditions.

III. **Use of This Standard.** It is the responsibility of the user of an AWWA standard to determine that the products described in that standard are suitable for use in the particular application being considered.

III.A. *Purchaser Options and Alternatives.* It is not the purpose of this standard either to define or recommend contractual relationships or to stipulate contractual obligations, which are all the responsibility of the purchaser. Generally, purchasers may solicit competitive bids for tendon-prestressed concrete tanks by one of two alternative methods.

Under the first method, a qualified engineer is retained by the purchaser to design the structure and prepare construction drawings, specifications, and other contract documents. Competitive bids are then solicited from constructors and suppliers for construction of the tank. In this standard, these are referred to as *purchaser-furnished designs*.

Under the second method, the purchaser prepares performance specifications that require bidding constructors to prepare detailed project designs and specifications and construct the tank according to the approved design. In this standard, these are referred to as *design-construct projects*.

Although the division of information that must be covered in the purchaser's specifications for execution of each project type differs substantially, depending on who is responsible for the tank design, the information that must be supplied by the purchaser to successfully apply this standard is essentially the same for both methods.

ANSI/AWWA D115 does not address matters related to site selection and property acquisition. It has been assumed that the purchaser will have conducted sufficient background work in the form of studies, predesign surveys, subsurface investigations,

and preliminary design work to establish the desired tank site, volume, operating water depth, and elevations. It is also assumed the purchaser will have acquired the property, easements, and rights-of-way necessary for construction of the tank structure and associated pipelines connecting it to the system. Finally, it has been assumed that the purchaser will accomplish and/or provide the following as necessary or appropriate:

1. Whether compliance with NSF/ANSI 61, Drinking Water System Components—Health Effects, is required for individual components and materials.
2. The site on which the tank is to be built, with adequate space to permit the constructor to erect the structure using customary methods.
3. A predesign site survey and preparation of a site plan showing existing topography, property lines, approximate tank location, setback, encumbrances, details of special construction features, and extent of final site grading.
4. A site geotechnical survey and foundation report, including logs of borings and test pits, and other pertinent soil and geological information, construction criteria for any backfill that may be necessary at a particular site, and foundation design criteria prepared by a professional engineer specializing in soil mechanics, including allowable bearing loads, anticipated total and differential settlements, and the seismic soil profile type.
5. Structure loading conditions, including but not limited to snow, wind, seismic, hydrostatic uplift, and other live loads, depending on the tank's intended use; the amount of earth cover over the tank, if any; the height of backfill against the tank wall, if any; and any other special loading conditions that are anticipated or special criteria on which the tank design is to be based. If, for example, the tank is located in a high-intensity earthquake area and must have an extra safety factor to continue to serve without damage, the purchaser may specify a greater importance factor for earthquake design than described in ACI 350.3 or provide design values for the horizontal acceleration and for the spectrum velocity.
6. A groundwater drainage and collection system plan.
7. Delivery of electric power and water service to the site.
8. Details of other federal, state or provincial, and local requirements (Section 2).

III.A.1 Information Required for Use of This Standard. The items that follow are either required information or alternative options in the standard that should be considered and covered in the purchase documents, unless the purchaser intends that the choice for a particular option be left to the tank designer's discretion.

1. The standard used, that is, ANSI/AWWA D115, Tendon-Prestressed Concrete Water Tanks, of latest revision.

2. The required tank capacity and either the plan dimensions or operating water depth.
3. The size, material, location, details, cover depths, and limits of responsibility of pipe connections.
4. The required elevation of the overflow weir and freeboard requirements.
5. The size, material, arrangement, and location of the overflow pipe.
6. Finish grade relative to the tank foundation. (Are the tank walls to be completely exposed, partially buried, or completely buried?)
7. Aboveground exterior concrete coatings, if required (Sec. 2.10.1).
8. Below-grade concrete coatings, if required (Sec. 2.10.2).
9. Design loading conditions (Sec. 3.3.1, 3.3.2, 3.3.3, and 3.3.4).
10. Type of roof structure required: flat with column supports or domed (Sec. 3.8, 3.9, and 3.10).
11. Freeze protection requirements (Sec. 3.12).
12. Tank appurtenances required:
  - a. Whether a removable silt stop is required.
  - b. Arrangement of inlet–outlet piping, including cover depths (Sec. 3.13.1).
  - c. Whether baffles are required (Sec. 3.13.1).
  - d. Encasement of piping beneath the floor slab (Sec. 3.13.1.3).
  - e. Design rates of inflow and outflow for design of overflow and vent systems (Sec. 3.13.2.1 and 3.13.2.5).
  - f. Tank drain line (Sec. 3.13.2.3).
  - g. Water level gauge or pressure sensor (Sec. 3.13.2.4).
  - h. Ventilation requirements (Sec. 3.13.2.5).
  - i. Roof openings and hatches (Sec. 3.13.3).
  - j. Access ladder and stair requirements (Sec. 3.13.4).
13. Details of other federal, state or provincial, and local requirements (Section 2).
14. Seismic importance factor.
15. Seismic soil classification from geotechnical foundation survey provided by the purchaser (Section 4).
16. Seismic spectral response accelerations,  $S_1$  and  $S_5$ , to be used for the tank design.
17. Watertightness criteria (Sec. 6.1.4).

**IV. Modification of Standard.** Any modification of the provisions, definitions, or terminology in this standard must be provided by the purchaser.

**V. Major Revisions.** The major revisions made to the standard in this edition include the following:

1. External tendon-prestressed circular tanks with a shotcrete covercoat are no longer covered within the scope of this standard.
2. Section 1 references have been updated.
3. The term *core wall* has been removed from the standard.
4. The term *shotcrete* has been added to the listing of definitions (Sec. 1.2, item 8).
5. References to ACI 301 have been changed to ACI 350.5, Specifications for Environmental Concrete Structures.
6. References to ACI 318 have been changed to ACI 350, Code Requirements for Environmental Engineering Concrete Structures and Commentary.
7. Material requirements for prestressing tendons and anchorages have been updated (Sec. 2.4).
8. Material requirements for ducts, sheathing, and elastomeric materials for waterstops, bearing pads, and sponge filler have been updated (Sec. 2.5, 2.6, and 2.7).
9. Sec. 2.11, Steel Corrosion Inhibitor, from the 2006 edition (ANSI/AWWA D115-06) has been removed from the present standard.
10. Requirements for NSF/ANSI 61 certification for concrete coatings, form coatings, interior liners, and sealants have been added (Sec. 2.10 and 2.11).
11. The inclusion of ACI 350 durability factor has been added to the design method (Section 3).
12. Allowable stresses in concrete, prestressed reinforcement, and nonprestressed reinforcement have been updated (Sec. 3.4).
13. The minimum thickness of membrane concrete slabs has been changed to 4 in. (Sec. 3.6).
14. Requirements for floor compressive stress, shrinkage and temperature reinforcement, construction joints, and subgrades have been updated (Sec. 3.6).
15. Design provisions for walls, concrete roofs, and dome roofs have been updated (Sec. 3.7, 3.8, and 3.9).
16. Concrete and shotcrete requirements have been updated (Sec. 3.11).
17. Provisions for tank appurtenances—inlet and outlet piping, tank overflows and drains, vents, and ladders and stairs—have been updated (Sec. 3.13).
18. Major revisions to earthquake design considerations have been made (Section 4). A section on Notation has been added (Sec. 4.1.3).

19. Qualifications for installation supervisors and other personnel have been updated (Sec. 5.2.4 and 5.3.6).

20. Provisions for grouting of prestressing tendons have been updated (Sec. 5.2.4.5).

21. Provisions for concrete placement have been updated (Sec. 5.2.5 and 5.2.6).

22. Provisions for precast concrete have been updated (Sec. 5.3).

23. Tolerance requirements have been updated (Sec. 5.6).

24. Watertightness criteria, testing, and repairs have been updated (Section 6).

25. A section on Affidavit of Compliance has been added (Section 8).

26. A section on Additional Design Considerations for roof openings, ladders and stairs, floors, and sponge rubber fillers has been added as appendix C.

27. Editorial clarifications have been made throughout the standard.

**VI. Comments.** If you have any comments or questions about this standard, please call the AWWA Engineering and Technical Services at 303.794.7711, FAX at 303.794.7603; write to the department at 6666 West Quincy Avenue, Denver, CO 80235-3098; or email at [standards@awwa.org](mailto:standards@awwa.org).



**American Water Works  
Association**

*Dedicated to the World's Most Important Resource®*

**ANSI/AWWA D115-17**  
(Revision of ANSI/AWWA D115-06)

**AWWA Standard**

---

# Tendon-Prestressed Concrete Water Tanks

---

## SECTION 1: GENERAL

---

### Sec. 1.1 Scope

This standard describes current and recommended practice for the design, construction, and field observations of concrete tanks using internal tendons for prestressing. This standard applies to containment structures for use with potable water, raw water, or wastewater.

### Sec. 1.2 Definitions

The following definitions shall apply in this standard:

1. *Epoxy bonding agent*: An epoxy used in repair processes to bond fresh plastic concrete mix, mortar, or epoxy mortar to hardened concrete.
2. *Epoxy mortar*: An epoxy mix used for repair of concrete.
3. *Horizontal wall joints*: Connection between the tank's wall and its foundation or floor slab or roof or dome. Types of joints may be generally defined as shown in Figures 2 and 3.
4. *Joint restraint conditions*: Top and bottom boundary conditions for the tank wall.
  - a. *Changing restraint*: A joint may be of a different type during and after prestressing. An example is a joint that is unrestrained during prestressing but is hinged after prestressing. The change in joint type is a result of

grout or curb installation, which prevents radial translation or lateral movement after prestressing.

b. Fixed: Full restraint of radial translation or lateral movement and full restraint of rotation.

c. Hinged: Full restraint of radial translation or lateral movement and negligible restraint of rotation.

d. Partially fixed: Full restraint of radial translation or lateral movement and partial restraint of rotation.

e. Unrestrained: Limited restraint of radial translation and negligible restraint of rotation.

5. *Membrane floor*: A highly reinforced (see Sec. 3.6), low-moment resistant slab-on-grade designed to be a flexible watertight floor system.

6. *Parties*: The persons, companies, or organizations generally involved in the purchase, design, and construction of tendon-prestressed concrete tanks. These include the following:

a. Bidder: The party from whom bids for construction of the tank are solicited or received by the purchaser.

b. Constructor: The party that provides the work and materials for placement or installation.

c. Design/build constructor: The firm that specializes in the structural design and construction of prestressed-concrete tanks. The firm shall have an experienced registered professional engineer on its staff, in its employ, or under contract who will assume responsibility for the structural design of such tanks.

d. Manufacturer: The party that manufactures, fabricates, or produces materials or products.

e. Prestresser: The person, company, or organization that applies the prestressing forces to the tank.

f. Purchaser: The person, company, or organization that purchases any materials or work to be performed.

g. Purchaser's engineer: The registered professional engineer representing the purchaser in the design of the tank and during its construction.

h. Supplier: The party that supplies material or services. A supplier may or may not be the manufacturer.

7. *Prestressing*: The application of compressive stresses to concrete through tendons prior to application of loads such as filling with water.



8. *Shotcrete*: Pneumatically applied mortar conforming with ACI\* 506.2.
9. *Specifications*: A document describing the requirements for the structure to be provided and containing the details of construction materials, methods, or constructor performance required in conjunction with the construction drawings and other contract documents for the structure.
10. *Standpipe*: A cylindrical structure for water storage having a wall height greater than its diameter. Standpipes are considered a special type of tank because of generally more critical loading conditions. Use of this standard in the design and construction of standpipes is not, however, precluded.
11. *Tank*: A structure for water storage based above, at, or below grade. In general, this term refers to a structure having a wall height equal to or less than its diameter or least plan dimension.
12. *Tendon*: High-strength steel elements, such as strands or bars, used to impart compressive stress to concrete. In pretensioned concrete, the tendon is only the bare strand. In post-tensioned (PT) concrete, the tendon includes the complete assembly consisting of end anchorages or couplers, prestressing steel and any coating materials, and sheathing filled with PT coating or ducts filled with grout.
  - a. *Anchorage*: In post-tensioning, a device or assembly used to transfer the tendon force to the concrete.
  - b. *Bonded tendon*: A prestressing tendon that is bonded to the concrete section with cement grouting. In a bonded internal tendon, the prestressing steel is bonded continuously to the concrete section through the duct corrugations after stressing and cement grouting.
  - c. *Circumferential tendon*: A horizontal tendon in a circular tank.
  - d. *Corrosion-inhibiting materials*:
    - i. *Cement grout*: A portland cement mix produced to inhibit corrosion and transfer bond in the ducts of bonded internal tendons.
    - ii. *Epoxy coatings*: Factory-applied epoxy coatings, with or without grit for bond.
    - iii. *Galvanizing*: Zinc coating.
    - iv. *PT coating*: Grease with corrosion-inhibiting additives that leaves no voids between the strand and sheathing in an unbonded tendon.
  - e. *Coupler*: A device that joins two pieces of a tendon.

---

\* American Concrete Institute, 38800 Country Club Drive, Farmington Hills, MI 48331.

f. Ducts: Corrugated tubing for forming internal voids in the concrete for bonded prestressing tendons. Also, smooth pipe for forming temporary voids in precast elements for unbonded tendons.

g. Prestressing steel: High-strength steel used to prestress concrete; commonly seven-wire strands, bars, or groups of strands.

h. Sheathing: Extruded polyethylene or polypropylene enclosures in which greased post-tensioning tendons are encased and waterproofed.

i. Unbonded tendon: A tendon encased in a PT coating and sheathing. The tendon is not bonded to the concrete section but anchored at each end after prestressing.

13. *Waterstop*: An impervious barrier installed to prevent passage of water through a construction or expansion joint between adjacent elements of concrete construction.

### Sec. 1.3 References

This standard references the following documents. In their latest editions, they form a part of this standard to the extent specified within the standard. In any case of conflict, the requirements of this standard shall prevail

ACI 302.1R—Guide to Concrete Floor and Slab Construction.

ACI 304R—Guide for Measuring, Mixing, Transporting, and Placing Concrete.

ACI 305R—Guide to Hot Weather Concreting.

ACI 306.1—Standard Specification for Cold Weather Concreting.

ACI 308R—Standard Practice for Curing Concrete.

ACI 334.3R—Construction of Concrete Shells Using Inflated Forms.

ACI 347R—Guide to Formwork for Concrete.

ACI 350—Code Requirements for Environmental Engineering Concrete Structures and Commentary.

ACI 350.1—Specification for Tightness Testing of Environmental Engineering Concrete Containment Structures and Commentary.

ACI 350.3—Seismic Design of Liquid-Containing Concrete Structures and Commentary.

ACI 350.5—Specifications for Environmental Concrete Structures.

ACI 423.7—Specification for Unbonded Single-Strand Tendon Materials.

ACI 503.2—Standard Specification for Bonding Plastic Concrete to Hardened Concrete With a Multi-Component Epoxy Adhesive.

ACI 504R—Guide to Joint Sealants in Concrete Structures.

ACI 506.2—Specification for Shotcrete.

ACI 515.2R—Guide to Selecting Protective Treatments for Concrete

ACI SP-2—*ACI Manual of Concrete Inspection*.

ANSI\*/AWWA C652—Disinfection of Water-Storage Facilities.

ASCE† 7—Minimum Design Load(s) for Buildings and Other Structures.

ASTM‡ A416/A416M—Standard Specification for Low-Relaxation Seven-Wire Steel Strand for Prestressed Concrete.

ASTM A475—Standard Specification for Zinc-Coated Steel Wire Strand.

ASTM A586—Standard Specification for Zinc-Coated Parallel and Helical Steel Wire Structural Strand.

ASTM A603—Standard Specification for Zinc-Coated Steel Structural Wire Rope.

ASTM A615/A615M—Standard Specification for Deformed and Plain Carbon-Steel Bars for Concrete Reinforcement.

ASTM A722/A722M—Standard Specification for Uncoated High-Strength Steel Bar for Prestressed Concrete.

ASTM A775/A775M—Standard Specification for Epoxy-Coated Steel Reinforcing Bars.

ASTM A882/A882M—Standard Specification for Filled Epoxy-Coated Seven-Wire Prestressing Steel Strand.

ASTM C260/C260M—Standard Specification for Air-Entraining Admixtures for Concrete.

ASTM C494/C494M—Standard Specification for Chemical Admixtures for Concrete.

ASTM C881/C881M—Standard Specification for Epoxy-Resin-Base Bonding Systems for Concrete.

ASTM C882/C882M—Standard Test Method for Bond Strength of Epoxy-Resin Systems Used With Concrete by Slant Shear.

ASTM C900—Standard Test Method for Pullout Strength of Hardened Concrete.

ASTM C920—Standard Specification for Elastomeric Joint Sealants.

ASTM C928/C928M—Standard Specification for Packaged, Dry, Rapid-Hardening Cementitious Materials for Concrete Repairs.

---

\* American National Standards Institute, 25 West 43rd Street, Fourth Floor, New York, NY 10036.

† American Society of Civil Engineers, 1801 Alexander Bell Drive, Reston, VA 20191.

‡ ASTM International, 100 Barr Harbor Drive, West Conshohocken, PA 19428.

ASTM C939/C939M—Standard Test Method for Flow of Grout for Preplaced-Aggregate Concrete (Flow Cone Method).

ASTM D695—Standard Test Method for Compressive Properties of Rigid Plastics.

ASTM D1056—Standard Specification for Flexible Cellular Materials—Sponge or Expanded Rubber.

ASTM D1752—Standard Specification for Preformed Sponge Rubber Cork and Recycled PVC Expansion Joint Fillers for Concrete Paving and Structural Construction.

ASTM D2000—Standard Classification System for Rubber Products in Automotive Applications.

ASTM D2240—Standard Test Method for Rubber Property—Durometer Hardness.

ASTM D4258—Standard Practice for Surface Cleaning Concrete for Coating.

ASTM D4259—Standard Practice for Abrading Concrete.

Federal Specification\* SS-S-210A—Sealing Compound for Expansion Joints.

IBC<sup>†</sup>—International Building Code.

PCI<sup>‡</sup> MNL-116—*Manual for Quality Control for Plants and Production of Precast Concrete Products.*

PTI—*Manual for Certification of Plants Producing Unbonded Single Strand Tendons.*

PTI/ASBI M50.3—*Guide Specification for Grouted Post-Tensioning.*

PTI DC10.7—*Post-Tensioned Commercial and Industrial Floors.*

PTI<sup>§</sup> M10.3—*Field Procedures Manual for Unbonded Single Strand Tendons.*

PTI M55.1—Specification for Grouting of Post-Tensioned Structures.

PTI TAB.1—*Post-Tensioning Manual.*

NSF/ANSI 61—Drinking Water System Components—Health Effects.

US Army Corps of Engineers Spec. CRD-C572—Specification for Polyvinylchloride Waterstop.

---

\* Naval Publications and Forms Center, 5801 Tabor Avenue, Philadelphia, PA 19120.

† International Code Council (ICC), 500 New Jersey Avenue, NW, 6th Floor, Washington, DC 20001.

‡ Precast/Prestressed Concrete Institute, 200 West Adams Street, #2100, Chicago, IL 60606.

§ Post-Tensioning Institute, 38800 Country Club Drive, Farmington Hills, MI 48331.

---

## SECTION 2: MATERIALS

---

Materials shall comply with the requirements of the Safe Drinking Water Act and other federal, state or provincial, and local regulations for potable water and wastewater systems as applicable.

### Sec. 2.1 Concrete and Shotcrete

2.1.1 *General.* The quality of concrete is of great importance to a tendon tank's structural integrity and watertightness. Therefore, care shall be taken throughout the construction to maintain close quality control of the materials, proportions, forming, embedded items, placement, finishing, curing, and other details of the work. In the context of watertightness, the aggregates used in concrete are impermeable and the permeability coefficient of cement paste having a low water–cement ratio is about  $10^{-14}$  m/sec. This renders uncracked, properly placed concrete essentially impermeable.

Concrete in water tanks that will be in contact with the stored water shall

1. Be dense and of very low permeability in order to retain water, minimize potential contamination of the water supply, and provide corrosion protection for the reinforcement steel.
2. Provide a surface that will facilitate cleaning and reduce maintenance. A smooth-formed wall finish for cast-in-place concrete, as defined by ACI 350.5, and precast panels of good workmanship standards will be acceptable.

2.1.2 *Concrete and shotcrete materials.* Concrete and shotcrete materials shall conform to the recommendations of ACI 350.5, ACI 350, and ACI 506.2, except as modified herein. The mix proportions shall be submitted to the purchaser and shall meet the strength and other requirements of the specifications. Prestressed concrete, including aggregates and admixtures, and cement grout in contact with bonded tendons shall not contain water-soluble chloride ions in excess of 0.06 percent of the weight of the cement in the mix. Concrete or shotcrete subject to freezing shall be air-entrained.

2.1.2.1 *Concrete.* Concrete shall be proportioned for a maximum water–cementitious materials ratio of 0.42 and other properties in accordance with ACI 350. Fly ash or other pozzolans that do not decrease durability are recommended for decreased permeability but are not required as a part of this standard. When pozzolans are part of the mixture, the water–cementitious materials ratio shall be 0.42 or less based on the cement plus pozzolans. Concrete shall be protected from

deterioration that can be caused by freezing and thawing, contact with aggressive soils, and other environmental or subsurface conditions. The requirements for the concrete shall be established based on the expected conditions. The criteria for the evaluation of sulfate conditions are covered in ACI 350.

2.1.2.2 *Shotcrete.* Shotcrete in domes shall not contain more than four parts sand to one part cement plus pozzolans by weight. Either the wet-mix or dry-mix process referred to in ACI 506R may be used for shotcrete domes unless the specifications require the use of a specific process, except that dry-mix shotcrete shall not be used in domes subject to freezing and thawing cycles. Wet-mix shotcrete for domes in areas subjected to freezing and thawing shall be air-entrained with an in-place air content of 5 to 7 percent. Shotcrete shall be proportioned for a 28-day strength not less than 4,500 psi (31 MPa).

2.1.3 *Cement mortar.* Mortar used for encasement of waterstops shall consist of not more than three parts sand to one part portland cement by weight and shall conform to the requirements of ACI 350.5. Mortar shall not contain water-soluble chloride ions in excess of 0.06 percent of the weight of the cement in the mortar.

2.1.4 *Cement grout.* Cement grout used for bonded tendons shall contain admixtures, used in accordance with the manufacturer's recommendations and PTI M55.1, Specification for Grouting of Post-Tensioned Structures, to prevent bleeding or grout settlement. Cement grout shall not contain water-soluble chloride ions in excess of 0.06 percent of the weight of the cement in the mix.

2.1.4.1 *Aggregates.* Aggregates, if used, in grouts shall pass a 1.18-mm (No. 16) sieve.

## **Sec. 2.2 Mixing Water**

Mixing water shall conform to the requirements of ACI 350 and shall be potable.

## **Sec. 2.3 Admixtures**

Admixtures shall comply with the requirements of ACI 350.5, ACI 506.2, or ASTM C494 and shall not contain chlorides, fluorides, sulfides, or nitrates in more than trace amounts, because of the possible corrosive effect of those substances on the prestressed reinforcement. Materials in contact with potable water shall not impart taste, odor, or toxic chemicals to the water. Admixtures shall be compatible with the cement, mineral additives, potable water, and other admixtures, when applicable.

Air-entraining admixtures shall conform to the requirements of ASTM C260.

## Sec. 2.4 Reinforcement

### 2.4.1 *Nonprestressed reinforcement.*

2.4.1.1 Reinforcing bars shall conform to the requirements of ASTM A615 and ACI 350. The coatings on epoxy-coated bars, when used, shall be in accordance with ASTM A775.

2.4.1.2 Dowels. Strand or dowel bars used for seismic ties in joints shall be either epoxy coated with grit or deformations for bond or galvanized. Epoxy-coated strand shall be in accordance with ASTM A882. Galvanized strand or bars shall conform to ASTM A416 or to ASTM A475, ASTM A586, ASTM A603, or ASTM A615 prior to coating. Zinc coating shall be 0.85 oz/ft<sup>2</sup> (0.26 kg/m<sup>2</sup>), in accordance with ASTM A475, Table 4, class B.

### 2.4.2 *Prestressed reinforcement.*

2.4.2.1 Tendons. Prestressed tendons shall conform to the requirements of 3.5.5 of ACI 350. In addition to ACI 350, materials shall conform to ASTM A416, ASTM A722, ASTM A882, and applicable sections of the PTI TAB.1, *Post-Tensioning Manual*. Unbonded single-strand tendons shall be fabricated at a plant certified by the Post-Tensioning Institute (PTI) Plant Certification Program for Unbonded Tendons.

2.4.2.2 Coatings. Epoxy-coated prestressing strand shall conform to the minimum elongation requirements of ASTM A416.

2.4.2.3 Anchorages. Anchorages or couplers for prestressed reinforcement shall conform to the requirements of ACI 350 and the PTI specifications. They shall be ferrous material compatible with the reinforcement and shall develop at least 95 percent of the actual breaking strength of the strand. Anchorages for unbonded tendons may be galvanized, epoxy-coated, or plastic-coated iron or steel. The anchorages for single-strand tendons shall be capped at the wedge cavity with a watertight cap filled with PT coating. A watertight plastic sleeve with any voids filled with PT coating or other means shall be connected to the anchorage such that no void spaces are left where water can accumulate. The encapsulated tendon assembly shall have been tested to 10 psi in accordance with ACI 350 and shall remain watertight.

## Sec. 2.5 Ducts

Duct material for bonded tendons shall be corrugated high-density polyethylene (HDPE) or high-density polypropylene (HDPP). Ducts shall be sufficiently strong to retain their shape during construction and shall be mortar-tight. Ducts

shall be manufactured for post-tensioning and meet the requirements of PTI/ASBI M50.3 specifications.

## **Sec. 2.6 Sheathing**

Sheathing for unbonded single-strand tendons shall conform to the requirements of ACI 350 and ACI 423.7. The sheathing for unbonded single-strand tendons shall be of virgin high-density polyethylene or high-density polypropylene, and it shall be produced by the seamless extrusion process over PT coating that leaves no air pockets and has a thickness of at least 50 mil (1.3 mm) with no negative tolerance.

## **Sec. 2.7 Elastomeric Materials**

### *2.7.1 Waterstops.*

2.7.1.1 PVC and TPV waterstops. PVC and thermoplastic vulcanized (TPV) waterstops shall be composed of ribbed virgin polyvinyl chloride containing no scrap or reclaimed material and meeting the requirements of CRD-C572 for tanks in cold-weather regions. TPV waterstops shall be composed of a fully cross-linked thermoplastic vulcanizate rubber. Splices shall be made in accordance with the manufacturer's recommendations subject to review by the purchaser. Tests ensuring conformity shall either be made on material delivered to the jobsite or be certified by an independent testing laboratory. PVC waterstops shall have a minimum ultimate tensile strength of 2,000 psi (13.78 MPa), an ultimate elongation of 350 percent, and shore A hardness of 70 to 80 durometer. TPV waterstops shall have a minimum ultimate tensile strength of 2,000 psi (13.78 MPa), an ultimate elongation of 400 percent, and shore A hardness of 80 to 90 durometer.

2.7.1.2 Adhesive waterstops. Preformed plastic adhesive waterstops shall conform to Federal Specification SS-S-210A. Other adhesive waterstops acceptable to the purchaser may be used.

2.7.2 *Bearing pads.* Bearing pads used to permanently support loads in floor-to-wall or wall-to-roof joints may consist of natural rubber, neoprene, polyvinyl chloride, or other proven materials with known physical properties that facilitate structural design. Temporary shims under precast panels that are subsequently grouted into nonmoving joints may be asphalt-impregnated cork or other materials acceptable to the purchaser.

2.7.2.1 Neoprene. Neoprene bearing pads shall have a minimum ultimate tensile strength of 1,500 psi (10.5 MPa), a minimum elongation of 500 percent, and a maximum compressive set of 50 percent with a shore A hardness of 30 to 60 durometer, in accordance with ASTM D2240. Neoprene bearing pads



shall contain only virgin crystallization-resistant polychloroprene as the raw polymer, and the physical properties shall comply with ASTM D2000, line call out M 2 BC 410 A1 4 B14 for 40-durometer material.

2.7.2.2 Natural-rubber bearing pads. Natural-rubber bearing pads shall contain only virgin natural polyisoprene as the raw polymer, and the physical properties shall comply with ASTM D2000, line call out M 4 AA 4 14 A1 3.

2.7.2.3 Polyvinyl chloride. Polyvinyl chloride for bearing pads shall meet the requirements of CRD-C572 for tanks in cold-weather regions.

2.7.3 *Sponge filler.* Sponge filler shall be closed-cell neoprene or rubber conforming to ASTM D1752, type I, or conforming to the requirements of ASTM D1056, grade 2A1 through grade 2A4.

## **Sec. 2.8 Epoxy Bonding Agent**

Epoxy used for increasing the bond of fresh plastic concrete or mortars to hardened concrete shall be a 100 percent solids, moisture-insensitive two-component epoxy adhesive meeting the requirements of ASTM C881, type II, grade 2, as specified in ACI 503.2. The bonding agent shall produce a bond strength, as determined by ASTM C882, greater than 1,500 psi (10 MPa) 14 days after the plastic concrete is placed. Epoxy in contact with potable water shall not impart taste or odor or leach trace elements into the water.

## **Sec. 2.9 Shrinkage-Compensating Grout**

Shrinkage-compensating grout shall meet all of the requirements of ASTM C928 and ASTM C939. Shrinkage-compensating grout shall not contain water-soluble chloride ions in excess of 0.06 percent of the weight of the cement in the mortar. Shrinkage-compensating grout shall be of the nonmetallic type. This grout shall be used to fill stressing pockets at tendon anchorages and to repair honey-combed concrete or other repairs.

## **Sec. 2.10 Concrete Coatings**

2.10.1 *Above grade.* In some cases, such as tanks located in areas subject to salt spray, coatings may be desired to seal the exterior surface of above-grade concrete and shotcrete domes. Coatings suitable for sealing the exterior of the tank shall be permeable to water vapor. Suitable coatings include latex-acrylic and modified-acrylate elastomers.

2.10.2 *Below grade.* Coatings are recommended to seal the exterior surface of below-grade tanks when exposed to aggressive soils. Coatings suitable for sealing the exterior of the tank wall include coal-tar epoxies and bitumastic compounds.

2.10.3 *Additional information.* Additional information on coatings for concrete may be found in ACI 515 2R. Concrete coatings in contact with potable water shall also be NSF/ANSI 61 certified.

2.10.4 *Form coatings.* For concrete surfaces that will be in contact with potable water, the form coating shall be nonstaining and NSF/ANSI 61 certified or fully removed before the tank's use.

2.10.5 *Interior liners.* Interior tank liners in contact with potable water shall be NSF/ANSI 61 certified.

### Sec. 2.11 Sealants

Sealants are used in construction joints and movement joints at the base of the wall. Polyurethane elastomeric sealants shall meet the requirements of ASTM C920. Sealants in contact with potable water shall be NSF/ANSI 61 certified.

---

## SECTION 3: DESIGN

---

### Sec. 3.1 Notation\*

$A_{ds}$  = total area of prestressing steel for dome ring (area)

$b$  = unit width (linear)

$d$  = distance from face of support (linear)

$D$  = unit dead load (force per unit area)

$E_c = 57,000 \sqrt{f'_c}$  short-term modulus of elasticity of normal weight concrete or shotcrete (force per unit area, psi)

$f'_c$  = specified 28-day compressive cylinder strength of concrete or shotcrete (force per unit area)

$f'_{ci}$  = specified compressive cylinder strength of concrete at time of prestressing (force per unit area)

$f_c$  = permissible compressive concrete or shotcrete stress (force per unit area)

$f_{pu}$  = specified ultimate tensile stress of steel prestressing strand or high-strength bars (force per unit area)

$f_{se}$  = effective stress in prestressed reinforcement after all losses (force per unit area)

$f_{si}$  = initial stress in prestressed reinforcement after friction losses but before long-term losses (force per unit area)

---

\* Caution should be used to be consistent throughout with respect to units.

- $f_t$  = tension in extreme fiber (force per unit area)  
 $h$  = depth of water contents (linear)  
 $k$  = buckling coefficient for dome shells  
 $l_d$  = development length for bond (linear)  
 $p$  = superimposed unit live load on dome shell (force per unit area)  
 $P_{fw}$  = final prestressing force for water load (force)  
 $r_d$  = radius of dome shell (linear)  
 $R$  = inside radius of tank (linear)  
 $R_c$  = response modification factor, convective  
 $R_i$  = response modification factor, impulsive  
 $S$  = safety factor—dome-roof buckling  
 $t_c$  = wall thickness (linear)  
 $t_d$  = dome-shell thickness (linear)  
 $u$  = nominal bond stress in concrete (force per unit area)  
 $v_c$  = nominal shear stress in concrete (force per unit area)  
 $v_{max}$  = maximum shear stress in reinforced section (force per unit area)  
 $W$  = total dead and live load on dome, exclusive of dome ring (force)  
 $\phi$  = capacity-reduction factor  
 $\omega$  = half central angle of dome shell (degrees)

### Sec. 3.2 Design Method

The tank wall, roof, and floor shall be designed for service loads and checked for required strength. Nonprestressed reinforcement designed using load factors shall include the “durability factor” of ACI 350. The design shall be based on elastic analysis using either analytical or numerical (e.g., finite element) methods. Rational inelastic analysis is also permitted (e.g., in verifying the crack width caused by temperature or moisture gradients and in seismic design). When applicable, the analysis shall account for boundary conditions between the wall and floor and between the wall and roof. The analysis shall take into account stages of loading: construction (specified or reviewed by the tank designer), service (including tank full and empty conditions), wind loads, seismic loads, and possible overloads.

If there is an apparent conflict between this standard and another code, the engineer-of-record shall determine the requirement.

### Sec. 3.3 Design Loads

Loads indicated in this section are those most frequently encountered in prestressed-concrete tank design and shall be included in the design as a minimum.

Loadings, including prestressing forces and their placement, shall be in accordance with this standard and governing codes.

3.3.1 *Wall design loads.* Wall design loads include the following:

1. Internal pressure. The pressure from water at the maximum overflow level (the level that develops the design overflow weir capacity).

2. Backfill loading. The lateral pressure from earth backfill. Net lateral loads, including those caused by unequal backfill, shall be determined by rational methods of soil mechanics based on foundation and soils investigations. Surcharge loads on backfill surfaces shall be considered. Backfill pressure shall not be used to reduce the amount of prestressing force required for resisting internal water pressure or other loads. Backfill forces shall be based on soil parameters for the “at rest” condition as established by a registered design professional experienced in soils.

3. Wind and earthquake loading. Minimum design loadings for wind shall conform to requirements of local building codes, such as the provisions of the International Building Code or ASCE 7. The seismic loads shall conform to those provided in ACI 350.3, as modified in Section 4 of this standard.

4. Construction effects. Effects of construction shall be considered, including loads resulting from surcharges on backfill, equipment, materials, and construction methods to be used.

5. Prestressing initial, temporary, and final forces and effects, including (1) bending moments and compressive stresses in the wall including those caused by nonlinear distributions of prestressing forces in circular walls, and (2) temporary bending moments developing during the stressing operation in circular walls.

6. External hydrostatic pressure on floor and wall from groundwater, if any.

7. Appurtenance loads.

8. Ice pressures from freezing of stored water. Alternatively, see Sec. 3.12 for ice prevention considerations in cold climates.

9. Thermal and moisture gradients through the thickness of the wall.

10. Thermal and moisture gradients, vertically, through the height of the wall that occur between the unburied and buried portions of the wall and above and below the tank’s high-water line.

11. Temperature and moisture difference between the wall and roof or wall and floor.

12. Anticipated total and differential settlement of the structure.

13. Strand-banding effects. For openings in cylindrical shell walls (man-holes, pipes, and other types) consideration must be given to the effects of banding of strands above and below the openings.

3.3.2 *Roof design loads.* Roof design loads include the following:

1. Dead loads.
2. Earth, snow, and other live loads.
3. Wind loads.
4. Earthquake loads.
5. Appurtenance loads.
6. Operational loads.
7. Temperature and moisture loads.
8. Construction loads.
9. Roof openings.

3.3.3 *Floor design loads.* Floor design loads include the following:

1. Dead loads.
2. Water loads.
3. Earthquake loads.
4. Uplift caused by groundwater or expansive soils.
5. Shear forces and moments from the base of the tank wall, when applicable.
6. Differential and total settlement.

3.3.4 *Control of loads.* Consideration shall also be given to load control techniques and their safety margins. Such techniques include the following:

1. Overflow systems.
2. Venting.
3. Under-floor drainage systems.
4. Perimeter drainage systems to limit hydrostatic pressures.
5. Internal freeboard to provide room for sloshing during an earthquake.

3.3.5 *Load factors.* Load factors, including durability factors, for strength design shall be as specified in ACI 350, except as follows:

Internal pressure of ice . . . . .	1.7
Initial prestress loading* . . . . .	0.9 or 1.3
Final prestress loading* . . . . .	0.9 or 1.4

Combinations of factored loads shall be in accordance with the ACI 350 code.

---

\* Use the factor that produces a more conservative design.

3.3.6 *Capacity-reduction factors.* Capacity-reduction factors,  $\phi$ , shall be in accordance with ACI 350 except for the following:

Tensile strength of axial reinforcement . . . . .	$\phi = 0.9$
Axial compressive strength of concrete . . . . .	$\phi = 0.7$

### Sec. 3.4 Allowable Stresses

Service-load stresses shall be limited to provide protection against leakage in or out of the tank and against corrosion of the reinforcement. Concrete cracking shall not be allowed under (predominantly) axial stresses. Cracking under (predominantly) flexural stresses shall be controlled to limit crack depth and width. Calculations shall show that crack depths in prestressed concrete without additional reinforcement do not penetrate to the prestressed reinforcement or more than one-third of the element thickness, whichever is smaller. Crack widths shall not exceed 0.004 in. (0.1 mm) under service-load conditions.

3.4.1 *Allowable stresses in concrete wall.* The allowable stresses in the wall concrete shall be as follows:

3.4.1.1 Maximum axial compression:

At initial prestress . . . . .	$0.55 f'_{ci}$
After long-term losses . . . . .	$0.45 f'_c$
Caused by wind and seismic . . . . .	$0.60 f'_c$

3.4.1.2 Minimum axial average residual compression:

- (a) internal pressure plus prestress after all losses. . . reference Sec. 3.6, 3.7.4.1, 3.7.5.1, and 3.8.1.
- (b) wind or seismic plus (a) . . . . . No tension allowed

3.4.1.3 Flexural extreme fiber compression of prestressed concrete:

Maximum at initial prestress . . . . .	$0.60 f'_{ci}$
Maximum at service loads . . . . .	$0.45 f'_{ci}$
Caused by wind or seismic . . . . .	$0.60 f'_{ci}$

3.4.1.4 Flexural extreme fiber tension of prestressed concrete, without non-prestressed reinforcement:

Caused by water, backfill, prestress, and other external loads. . . . . No tension allowed

(Flexural tension from external loads must be taken by nonprestressed reinforcement at the stresses given in Sec. 3.4.3.)

Caused by temperature and moisture gradients:

Outside face . . . . .	$3\sqrt{f'_c}$
Inside face . . . . .	$2\sqrt{f'_c}$

Caused by wind or seismic:

Outside face . . . . .	$6\sqrt{f'_c}$
Inside face . . . . .	$3\sqrt{f'_c}$

3.4.1.5 Flexural extreme fiber tension with nonprestressed reinforcement.

The amount of nonprestressed reinforcement shall be sufficient to control crack widths with the assumption that the stress in the concrete in tension is zero. See Sec. 3.4.3.

3.4.2 *Allowable stresses in prestressed reinforcement.*

3.4.2.1 Calculation. The allowable stresses in prestressed reinforcement and requirements for calculating prestressing losses shall be in accordance with ACI 350, latest edition, and Sec. 3.7.10 of this standard.

3.4.2.2 Horizontal stress. For tank walls, in addition to the service-load requirements above, the resultant tensile stress in the horizontal prestressing steel under the combined factored effects of hydrostatic and hydrodynamic (seismic) fluid pressure (see Section 4) shall be not greater than  $0.75f_{pu}$ , where  $f_{pu}$  is the specified ultimate strength of the prestressing steel. The prestressing steel shall resist the entire net tension.

3.4.3 *Allowable stresses in nonprestressed reinforcement.*

3.4.3.1 Working stress design. The allowable stresses in nonprestressed reinforcement computed on the basis of a working stress design shall be in accordance with ACI 350.

3.4.3.2 Seismic effects. Whenever seismic effects, combined with other load effects that can act simultaneously and cause flexural-tension stresses in the tank wall, are in excess of Sec. 3.4.1.4 (for prestressed concrete), bonded nonprestressed reinforcement shall be provided within 1 in. (25 mm) to 2 in. (50 mm) of the tension face of the wall. The area of this reinforcement shall be in accordance with ACI 350. Maximum spacing of bonded reinforcement shall be three times the wall thickness, or 24 in. (600 mm), whichever is least.

## Sec. 3.5 Footing Design

3.5.1 *Wall footing.* Wall footings shall be cast integrally with the floor. Stresses in nonprestressed reinforcement in nonprestressed wall footings caused by radial base shear from the wall in circular tanks shall be limited to 14,000 psi (95 MPa). Flexural forces in footings shall be designed in accordance with ACI 350.

The footing shall be founded at a depth capable of bearing the load and below the local depth of frost penetration. The footing shall be designed for all the loads acting on it at the calculated eccentricity, including, but not limited to, the wall and

roof loads, the flexural reaction when the foundation and floor slab are intended to provide restraint of rotation of the wall base (outward caused by water for full tank and inward caused by backfill for empty tank), wind or seismic loads, and other loads. The footing and integral floor slab shall resist the entire shear resulting from the wall boundary conditions at its base. The footing and floor slab shall resist the entire shear caused by wind or seismic loads.

**3.5.2 Column footings.** Column footings shall be designed in accordance with ACI 350. Column footings may be cast integrally with the floor (either above or below the floor) or may be cast separately directly on top of the floor diaphragm. Dowels or intentionally roughened surfaces should be provided when separate placements are used. The roughening shall be sufficient to remove bond-inhibiting products, such as curing compounds, and to promote mechanical bond of the footing concrete to the floor concrete. Methods such as water blasting and sand blasting have been found effective.

### **Sec. 3.6 Floor Design**

Under normal conditions, tank floors shall be concrete membrane slabs-on-grade supported directly on a prepared subgrade.

Membrane concrete slabs shall be not less than 4-in. (100-mm) thick. They shall be biaxially reinforced with prestressed and/or nonprestressed reinforcement. Concrete protection for reinforcement shall be in accordance with Sec. 3.11. Design of prestressed slabs shall produce a minimum average compressive stress after all losses and after allowance for slab–subgrade friction of 125 psi (0.86 MPa) for an empty tank, and a residual compressive stress of 100 psi (0.7 MPa) for tanks intended to remain in use 90 percent of the time or more, and 200 psi (1.4 MPa) for other tanks after allowance for tensile forces resulting from the wall–base reaction. Slab–subgrade friction and the friction coefficient shall be in accordance with the Post-Tensioning Institute publication *Post-Tensioned Commercial and Industrial Floors*, for type II slabs.

It is recommended that prestressed floor tendons be stressed in two stages: one-half stress in each tendon within 3 days after placement or earlier, if the strength of the concrete reaches 1,500 psi (11 MPa), and full stress in each tendon within 10 days or as soon as the strength of the concrete has reached 3,000 psi (21 MPa). Alternatively, special anchorages, designed for full tendon stress at the anchorages within 3 days or as soon as the strength of the concrete has reached 2,000 psi (20 MPa), may be used to avoid staged stressing.



Nonprestressed floors shall be designed such that the shrinkage and temperature reinforcement ratio in each orthogonal direction is at least 0.0028 if effective means of minimizing slab-subgrade friction and other forms of restraint are taken, 0.005 for normal restraint conditions in each orthogonal direction, and as required below parallel to any construction joints.

In sites with extremely poor soils, large hydrostatic uplift forces, or where undue differential settlement or uplift potentials exist, the floor may be a structural slab supported by individual piers, piles, or footings. Structural floors shall be designed in accordance with the requirements of ACI 350. Structural floor designs shall account for any flexural loads plus axial loads from base restraints as applicable.

Construction joints in the floors are discouraged as they tend to cause shrinkage cracks and seepage. Joints, if used, shall have waterstops (Figure 1). The slab at the joint may be thickened to allow additional room for the waterstop and reinforcement. For restrained joints, the reinforcement shall be continuous through

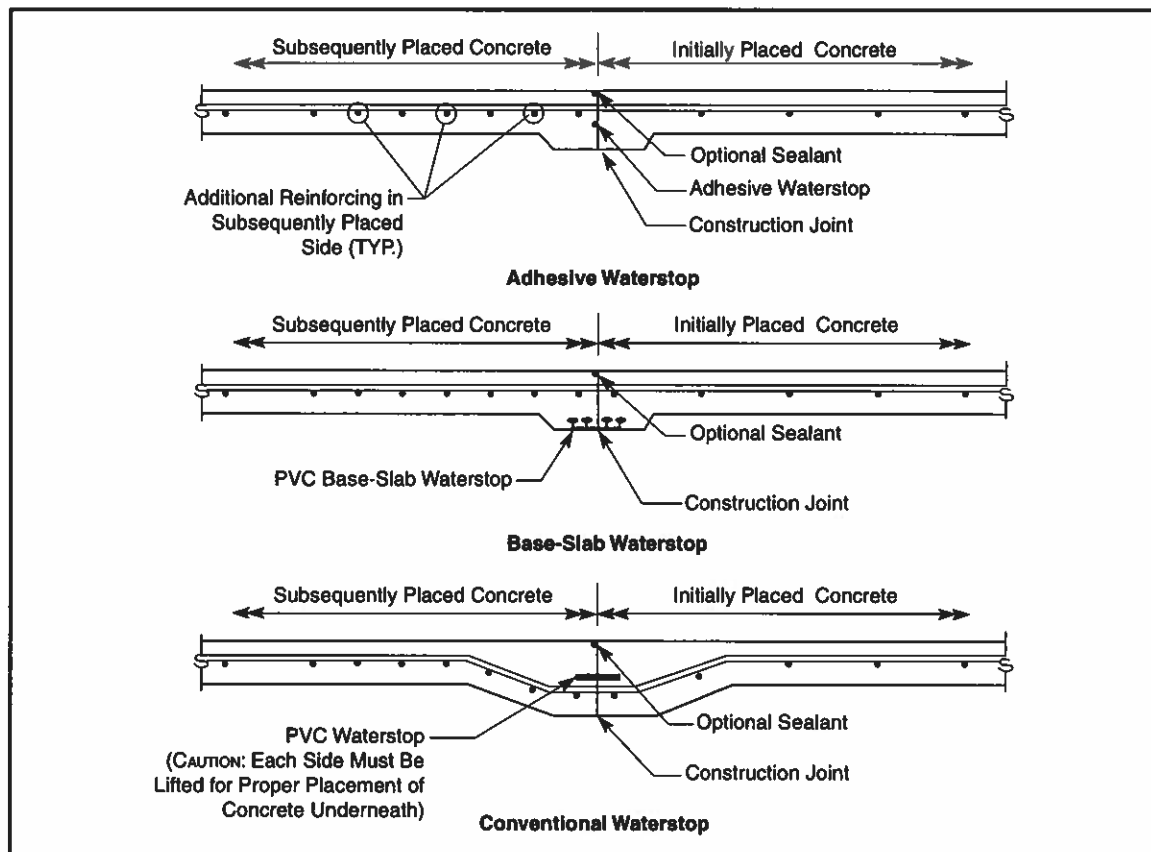

Figure 1 Typical floor-slab construction joints

the joints. Construction joints shall be kept to a minimum, with due regard to shrinkage effects of concrete and practicality of the size of the concrete placement. For restrained joints, conventional reinforcement totaling at least 0.010 times the cross-sectional area of the thickened portion of slab plus 6 ft (1.8 m) of the membrane slab shall be provided parallel to the construction joint in the subsequently placed portion of the slab. For floor concrete placed “checkerboard style,” the 0.010-reinforcement-ratio requirement shall apply to the entire area of the subsequently placed sections.

The subgrade of membrane slabs and slabs-on-grade shall be uniform and compacted to provide sufficient bearing capacity to support the tank and its loads, in accordance with soil and geological information. The subgrade shall also be stabilized so that it will not be displaced by foot traffic or the placement of concrete.

Hydrostatic uplift when the tank is empty shall be precluded by proper surface drainage around the tank and, if necessary, by underdrainage.

Floor penetrations shall be similar to wall penetrations (see Sec. 3.7.7).

### **Sec. 3.7 Wall Design**

**3.7.1 Introduction.** The walls of tanks covered by this standard have horizontal prestressing. They may be cast-in-place, preferably in full-height segments, or precast, sequentially placed around the tank.

**3.7.2 Analysis.** The wall shall be analyzed for the load cases set forth in Sec. 3.3.1 using the elastic theory appropriate for the shape of the tank. For circular tanks, the analysis shall determine wall radial deflection at top and bottom of wall and any other applicable locations (such as at concrete launders interacting with the tank wall), circumferential axial force, and the radial shear force. For all wall shapes, the analysis shall determine the vertical and horizontal bending moments. Analysis shall be performed for liquid levels between the “tank empty” and the “tank full” conditions, if required to determine the controlling flexural stresses.

Tank wall stresses shall be determined without the benefit of the effects of external loads, such as backfill or hydrostatic pressures. Appropriate boundary conditions that exist at the time of application of each load (including prestressing) shall be used in the analysis: free, hinged, or fixed. For boundary conditions that fall between two of these three conditions, stresses shall be determined for both boundary conditions and a maximum stress envelope shall be used to design the wall. For example, walls intended to be restrained against rotation at the base shall also be designed for partial release of that rotational restraint caused by footing rotation based on the modulus of subgrade reaction of the soil. When soil data are not provided, one-half release of

the fixed condition shall be assumed. Wall reactions at the boundaries shall be determined for use in the roof and foundation design.

When prestressing tendon forces cause vertical bending moments in circular prestressed-concrete tank walls, they shall be multiplied by a phi factor ( $\phi$ ) of 0.9 or 1.1 prior to combination with external load effects such as water or backfill. Use whichever factor adds to the external load effect under consideration.

Stresses caused by slow-changing temperature and moisture gradients may be determined using the moment of inertia of a cracked section and, because of the effects of creep, a modulus of elasticity of one-third the short-term modulus of elasticity.

Stresses caused by fast-changing temperature gradients may be determined using a cracked section and the normal short-term modulus of elasticity. The depth of the cracks in the cracked section for vertically prestressed sections, however, shall not exceed the concrete cover over the vertical prestressed reinforcement. When wind or earthquake loads are added to the preceding loads, a one-third increase in allowable stresses in the concrete and reinforcement may be used.

**3.7.3 Wall thickness.** The wall thickness shall be such that (1) compressive stresses for the empty tank under external loads and horizontal prestress are within allowable limits, (2) flexural stresses and reinforcing bars are not excessive, and (3) concrete cover is as required by Sec. 3.11 and the concrete placement can take place without segregation.

For proper placement of concrete, the following values shall be used as minimum thicknesses for the walls:

Cast-in-place . . . . .	9 in. (230 mm)
Precast with internal prestressing . . . . .	7 in. (175 mm)

**3.7.4 Horizontal prestressing.** Horizontal prestressing shall take axial tension plus provide residual compressive stress. Nonprestressed reinforcement may be added in areas of flexural tension, such as in the corners of rectangular tanks. The design of the tank reinforcing steel shall be in conformance with the requirements and restrictions of ACI 350.

The connection between the wall and floor shall be fixed, hinged, or supported on bearing pads. During stressing of the horizontal post-tensioning tendons, the wall shall be unrestrained except from that restraint that occurs at bearing pads or other low-friction supports. Similarly, the wall–roof joints of tanks should be unrestrained during stressing of the horizontal post-tensioning tendons except from that restraint that occurs at bearing pads or other low-friction roof supports. The effects

of low-friction restraints at the bottoms or tops of the walls should be accounted for in the design.

3.7.4.1 Horizontal tendons. Horizontal tendons in circular tanks or curved sections of other nonstraight shapes shall be placed no closer than half the wall thickness from the inside face of the wall. In all tanks, the minimum clear distance between bonded tendon, ducts, or groups of side-by-side unbonded tendons should not be less than 2 in. (50 mm), two times the maximum size of the aggregate, the diameter of the duct, or the width of groups of side-by-side unbonded horizontal tendons, whichever is greater. In curved tank walls, the minimum spacing of bonded tendons or groups of side-by-side unbonded tendons shall also limit the tensile stress in the concrete between adjacent ducts caused by tendon curvature to  $1.2\sqrt{f'_c}$ . Alternatively, hairpins or other nonprestressed reinforcement may be provided in the wall to counteract the radial tensile splitting forces in the wall created by curved post-tensioning tendons.

The maximum center-to-center spacing of horizontal tendons shall be consistent with the elastic analysis required in Sec. 3.7.2. The minimum final (after all losses) horizontal prestressing force to contain the internal loads at any point in the gross wall section shall include provision for the calculated stresses caused by through-the-wall-thickness thermal and moisture gradients (but not less than 100 psi [0.7 MPa]), or allowance for a minimum residual compressive stress of 200 psi (1.4 MPa) for the aboveground portion of the tank wall, tapering to 50 psi (0.35 MPa) at the expected frost penetration depth belowground, with the tank filled to the overflow level.

For tanks without roofs (open at the top of the wall), the residual compression shall include provision for the calculated stresses caused by vertical thermal and moisture gradients, or allowance for a minimum residual compressive stress of 400 psi (2.8 MPa) for the exposed top portion of the tank wall, tapering to at least that required for the through-the-wall-thickness thermal and moisture gradients required above at not less than 6 ft (1.8 m) below the normal operating level of the water surface.

External loads caused by backfill or hydrostatic pressure shall not be used to reduce circumferential prestressing.

Horizontal prestressing shall be post-tensioned after the wall is complete and the concrete has obtained at least the initial compressive strength ( $f'_{ci}$ ) required by the design.

3.7.4.2 Nonprestressed horizontal reinforcement. When nonprestressed horizontal reinforcement is used in combination with horizontal prestressed

reinforcement, the spacing of the horizontal nonprestressed reinforcement in tanks with fixed or partially fixed corners shall not exceed 12 in. (300 mm) on center. At other locations where horizontal reinforcement is required because of stresses, the spacing of the reinforcement shall not exceed three times the wall thickness.

**3.7.5 Vertical reinforcement.** Vertical reinforcement may be prestressed, nonprestressed, or a combination of both (partially prestressed). For prestressed vertical reinforcement, the minimum average axial compression after all losses shall include provision for the calculated stresses for thermal and moisture gradients, but not less than 125 psi (0.86 MPa), or 200 psi (1.4 MPa) for aboveground tanks, or 125 psi (0.86 MPa) for fully belowground tanks. Partially prestressed walls may have any combination of vertical prestressed reinforcement and nonprestressed reinforcement that satisfies calculated stresses for thermal and moisture gradients and vertical bending moments.

Stirrups or ties shall be provided at the anchorages to resist the splitting forces in the wall caused by the application of force to tendons placed inside the wall.

**3.7.5.1 Vertical prestressing.** Vertical prestressing, if used, shall provide average axial compression of at least 125 psi (0.86 MPa) after all losses. Otherwise, the wall is considered partially prestressed. The spacing of the vertical tendons in vertically prestressed tanks with fixed base restraints (Figure 2A) shall not exceed three wall thicknesses. In tanks without fixed base restraints, vertical tendon spacing shall not exceed five wall thicknesses. Either allowable stresses set forth in Sec. 3.4 or the modified-strength method described in ACI 350 shall be used to determine the amount of additional nonprestressed reinforcement required if flexural tension from external loads exceeds the compression provided.

When nonprestressed vertical reinforcement is used in combination with vertical prestressed reinforcement, the spacing of the vertical nonprestressed reinforcement in tanks with fixed base restraints (Figure 2A) shall not exceed 12 in. (300 mm) on center in regions of flexural tension in the base region. At other locations where vertical reinforcement is required because of stresses, the spacing of the reinforcement shall not exceed three times the wall thickness.

**3.7.5.2 Nonprestressed vertical reinforcement.** When only nonprestressed vertical reinforcement is used, its design shall be based on either the working-stress design method using the allowable stresses set forth in Sec. 3.4 or the modified-strength design method of ACI 350. In this case, the spacing of the vertical nonprestressed reinforcement shall not exceed 12 in. (300 mm) on center.

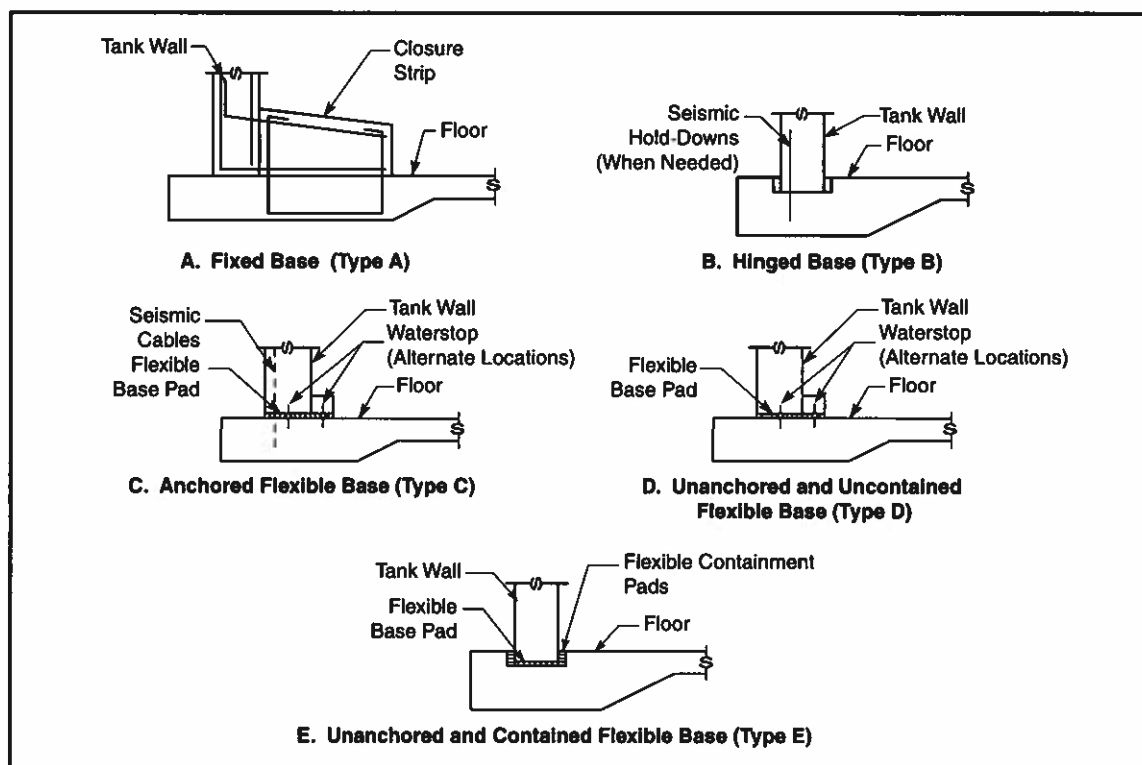

Figure 2 Types of joints used between the wall and foundation of concrete water-storage tanks

3.7.6 *Shear.* The radial and lateral shear strength of the tank wall shall be provided in accordance with the Special Provisions for Walls section of ACI 350.

3.7.7 *Wall penetrations.* Penetrations for piping and manholes should be avoided in walls, if possible. If unavoidable, they may be located in walls with proper sealing around the penetration to preclude loss of water. Prestressing tendons may be anchored at specially designed steel frames or diverted around the penetration and returned to its original axis in a distance not less than six times the offset on each side, unless a rigorous stress analysis is performed to use a shorter distance. The minimum clear spacing between the tendon and the edge of the penetration shall be as required for concrete cover. Metallic pipe penetrations shall have the clear cover required in Sec. 3.11 from the tank reinforcing. Flexible couplings outside tank walls are recommended for pipe penetrations.

3.7.8 *Stressing locations.* Stressing locations for horizontal tendons are generally at the corners of rectangular tanks or staggered among buttresses, couplers, or in-line devices that are spaced around the tank's perimeter. The spacing of stressing locations is a function of stress loss in the tendon caused by friction, the desire for

a uniform horizontal prestressing distribution, and, for bonded tendons, the ability during construction to pull or push the strands through the tendon duct. The number of buttresses or stressing locations used is normally a function of the economic balance between buttress and tendon anchorage cost and the effective prestressing force in the tendon (cost of the tendon) after allowance for friction and long-term losses. Generally, two buttresses are used on small circular tanks, and four or more stressing locations are used on larger tanks. The wall design shall be based on the effective prestressing force that is the lowest average between adjacent tendons.

Buttresses shall be designed for the prestress eccentricity, tendon curvatures, and anchorage forces of the horizontal tendons using strut-and-tie or finite element methods.

**3.7.9 Wall-construction joints.** Horizontal construction joints are not recommended in the tank walls. If horizontal joints are needed, the entire portion of the wall above the construction joint shall have the nonprestressed shrinkage and temperature reinforcement of ACI 350 in addition to the prestressing. Construction joints, which are the interface between prior cast concrete and subsequently placed concrete, shall be watertight. Some designs include adhesive or PVC water-stops; others include sand-blasted concrete surfaces and vertical strips of liner or sealant on the interior face.

**3.7.10 Prestress losses.** Short-term prestress losses, such as loss caused by friction and anchorage seating, as well as long-term prestress losses (such as losses caused by elastic shortening, shrinkage, and creep of concrete) and stress relaxation of the prestressing steel, shall be accounted for in the design. Interaction between shrinkage, creep, and stress relaxation shall be recognized in the calculations. Long-term losses shall be based on the average of the amounts calculated assuming the tank is always full and always empty. The minimum long-term losses shall be 10,000 psi (70 MPa) for low-relaxation strand and 25,000 psi (170 MPa) for normal-relaxation strand.

## **Sec. 3.8 Concrete Roofs**

**3.8.1 Prestressed.** Prestressed-concrete roofs shall be designed in accordance with ACI 350 and the concrete cover requirements set forth in Sec. 3.11. A minimum effective average axial stress of 125 psi (0.86 MPa) is required. Additional prestressing may be required to resist flexural, axial, thermal, and other stresses such as from the wall-top support in rectangular prestressed tanks.

**3.8.2 Nonprestressed.** Nonprestressed concrete roofs shall be designed in accordance with ACI 350 and shall be watertight. Roof designs shall account for

any flexural, axial, thermal, and other stresses such as from the wall-top support in rectangular prestressed tanks.

### 3.8.3 *Roof joints.*

3.8.3.1 *Wall-roof joints.* It is recommended that unrestrained wall-roof joints be used on circular and curved wall sections of rectangular tanks with rounded corners or ends. Joints that provide lateral support of the top of the wall but not longitudinal restraint of roof shrinkage and temperature movements have also been developed to help prevent shrinkage cracks in the roof. When restrained wall-roof joints are specified, reinforcement to distribute shrinkage cracks equivalent to a minimum of 0.8 percent of the cross-sectional area of the concrete for one-half the distance to the first row of columns in the roof slab (adjacent to the joint) shall be provided. This reinforcement shall be placed in a direction parallel to the wall.

3.8.3.2 *Roof construction joints.* Construction joints in the roof should be minimized or, preferably, eliminated. When restrained roof construction joints are used, the concrete placed against a previously placed roof section shall have a reinforcement ratio of 0.010 for at least the first 6 ft (2 m) placed parallel to the joint. For roof concrete placed “checkerboard style,” the 0.010-reinforcement-ratio requirement shall apply to the entire area of the subsequently placed sections.

3.8.3.3 *Watertightness.* Roof construction joints shall incorporate waterstops, sealants, or other measures to achieve watertightness.

3.8.3.4 *Penetrations.* Roof penetrations shall be similar to wall penetrations (see Sec. 3.7.7).

3.8.4 *Minimum roof slope.* The minimum roof slope shall be 1.5 percent unless a suitable roofing coating or membrane is provided. If used, the coating or roofing system shall allow for relief of vapor pressure.

3.8.5 *Columns.* Columns shall conform to the requirements of ACI 350.

## Sec. 3.9 **Dome Roof Design**

3.9.1 *General.* The concrete and shotcrete dome designs described herein are for typical dome roofs commonly used in current practice for some circular tanks. It is not the intent of this standard to preclude other dome designs that are in conformance with currently accepted standards. See ACI 334.3R for recommendations when using inflated forms for dome roof construction.

Dome (spherical shell) roofs generally have rise-to-span ratios of between 1:12 and 1:8. A circumferentially prestressed dome ring shall be provided at the base of the dome to furnish horizontal restraint of the dome thrust. Figure 3A and Figure 3B illustrate typical details at the lower edge of the dome, including



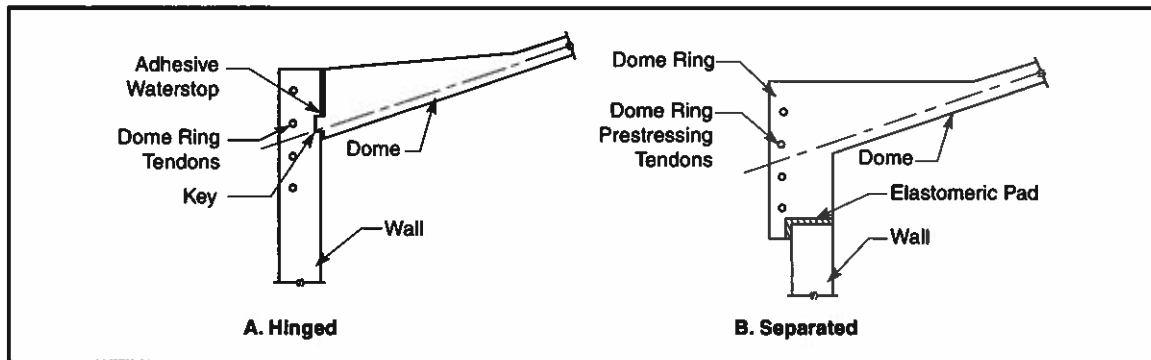

Figure 3 (A) Hinged dome–wall connection; (B) Separated dome–wall connection

arrangement of dome ring and connection with the tank wall. Consideration shall be given for severe exposure conditions and condensation on the underside of the dome. Dry-mix shotcrete shall not be used in construction of domes in areas subjected to freeze–thaw cycles.

3.9.2 *Design method.* Concrete or shotcrete dome roofs shall be designed on the basis of elastic shell analysis.

3.9.3 *Thickness and reinforcement.* Dome-shell thickness is governed either by buckling resistance, by minimum thickness for practical construction, or by corrosion protection of the reinforcement. Minimum thickness of the monolithic concrete or shotcrete dome shall not be less than 4 in. (100 mm).

3.9.3.1 *Thickness.* A method for determining the minimum thickness of a monolithic concrete spherical dome shell to provide adequate buckling resistance is given in appendix A, ref. 13. This method is based on the elastic theory of dome shell stability with consideration of the effects of creep, imperfections, and experience with existing tank domes having large radius-to-thickness ratios. Based on this, the minimum recommended dome thickness for buckling is

$$\min t_d = r_d \sqrt{\frac{1.5 P_u}{\phi \beta_i \beta_c E_c}}$$

Where:

$t_d$  = thickness of dome shell, in.

$r_d$  = inside radius of dome, ft

$P_u$  = factored unit (uniformly distributed) design load for the dome shell caused by dead load and live load, psf

$\phi$  = capacity-reduction factor

$\beta_i$  = buckling reduction factor for geometrical imperfections from a true spherical surface, such as local increases in radius

$\beta_c$  = buckling reduction factor for creep, nonlinearity, and cracking of concrete  
 $E_c$  = modulus of elasticity of concrete under short-term load, psi

The conditions that determine the factors  $\beta_i$  and  $\beta_c$  are discussed in appendix A, ref. 13. The values for these factors, given in Items 3 and 4 in the following list, are recommended for use when domes are designed for conditions where live load is 12 lb/ft<sup>2</sup> (575 Pa) or more, water is stored inside the tank, dome thickness is 4 in. (100 mm) or more,  $f'_c$  is 4,000 psi (28 MPa) or more, normal weight aggregates are used, and dead load is applied (i.e., shores removed) not earlier than 7 days after concrete placement, with curing as required in ACI 350.5. Recommended values for the terms for such domes are as follows:

1.  $P_u$  is obtained using the minimum load factors of 1.4 for dead load and 1.7 for live (snow) load.
2.  $\phi = 0.7$ .
3.  $\beta_i = (r_d/r_i)^2$  In the absence of other criteria,  $r_i$  may be taken as  $1.4r_d$  and in this case:  $\beta_i = 0.5$ .
4.  $\beta_c = 0.44 + (0.003)L$  for live loads between 12 and 30 lb/ft<sup>2</sup> (575 and 1,450 Pa).  $\beta_c = 0.53$  for live loads of 30 lb/ft<sup>2</sup> (1,450 Pa) or greater.
5.  $E_c = 57,000 \sqrt{f'_c}$  for normal-weight concrete or shotcrete.

Precast concrete panel dome shells may be used in dome construction, provided the designer makes allowance for joints between panels that are not equivalent in strength or thickness to a monolithic shell.

**3.9.3.2 Reinforcement.** The area of reinforcing steel in a monolithic dome, excluding the dome ring, shall be not less than 0.28 percent of the concrete cross-sectional area ( $0.0028bt_d$ ) in both the circumferential and radial directions. This minimum reinforcement may need to be increased for unusual temperature conditions. The reinforcement shall be placed approximately at the mid-depth of the shell, for domes 5 in. (125 mm) or less in thickness. In the edge region, two layers of reinforcement shall be provided, one near each face.

**3.9.3.3 Precast domes.** Precast domes shall provide the same minimum safety factors for strength and resistance to buckling as required for a cast-in-place monolithic dome. Precast domes shall incorporate waterstops or joint sealants at joints.

**3.9.4 Dome-edge region.** The edge region of the dome and the top region of the wall are subject to bending stresses that arise because deflections at the intersection of the dome ring and cylindrical wall differ from the membrane condition because of the dome and wall prestressing and loading conditions. These stresses

can be reduced to levels that do not impair tank performance by the proper design of the dome-wall joint. Factors that affect bending stresses are type of joint (fixed, hinged, or separated), size of dome ring, initial prestress force on the ring and on the adjacent wall, and the thickness of the dome-edge region. The edge effects may require thickening of the dome near its edge, radial reinforcement in the top and bottom of the dome-edge region, and vertical reinforcement in each face of the upper portion of the tank wall.

**3.9.5 Dome ring.** Circular prestressing of the dome ring is necessary to eliminate or control circumferential tension in the dome ring. Wall-to-dome connections shall minimize edge-bending effects in the dome and upper portion of the tank wall.

**3.9.5.1 Area.** Unless a more accurate analysis is made, the area of prestressing steel  $A_{ds}$  to resist total dead and live load  $W$  shall be taken as follows:

$$A_{ds} = \frac{W \cot \omega}{2\pi f_{se}}$$

**3.9.5.2 Force.** In a more accurate analysis, the prestressing force may be provided to counteract only that tension caused by dead load plus the minimum residual prestressing given in the rest of this paragraph. If prestressing for less than the full live load is used, sufficient area of prestressing steel shall be maintained at reduced stress, or additional nonprestressed reinforcement shall be added to provide strength for the remainder of the live load, in accordance with the requirements of ACI 350. A minimum residual circumferential compression matching that of the wall shall be provided in the dome ring under dead load plus one-half live load on the dome.

**3.9.5.3 Excess.** Prestressed reinforcement in excess of that required for dead-load thrust increases bending and compression stresses in the dome ring, in the edge region of the dome, and in the upper part of the wall when the upper part of the wall is monolithic with the ring. The ring shall be proportioned such that the initial nominal compressive stresses are limited to  $0.55f_{ci}'$  based on the net cross section of the ring, excluding haunches or adjacent wall if a separated wall-dome ring is used.

**3.9.5.4 Shrinkage and temperature effects.** Nonprestressed reinforcing steel shall be used in the dome ring to control shrinkage and temperature effects prior to prestressing. Minimum area of circumferential steel shall be 0.0025 times the cross-sectional area of the dome ring.

3.9.5.5 Restraint. When the dome ring is separated from the tank wall, positive means of restraint, such as a containing lip, keyway, flexible seismic cables, or doweling, shall be provided to prevent lateral displacement of the dome in the event of seismic activity. Figure 3B shows a downward-projecting lip on the ring. Where such a detail is used, the joint width shall be sufficient to accommodate radial movement at the top of the wall during circumferential prestressing and fluctuations in water level.

**Sec. 3.10 Other Roof Designs**

Other types of roof structures constructed of steel, aluminum, or fiberglass-reinforced plastic may be used if designed in conformance with currently accepted standards. The design shall provide a weather-tight roof to prevent leakage and contamination, when applicable. Consideration shall be given to the effects of severe exposure conditions and condensation on the underside of the roof.

**Sec. 3.11 Concrete and Shotcrete Cover**

The following minimum concrete or shotcrete covers shall be provided for nonprestressed reinforcement and anchorages.

3.11.1 *Prestressed concrete.* For prestressed concrete, the following minimum covers shall be provided:

- Bottoms of two-way prestressed wall and column footings, membrane slabs, and slabs-on-grade, cast against and permanently exposed to stabilized subgrade and plastic sheeting . . . . . 1.5 in. (38 mm)
- Bottoms of two-way prestressed wall and column footings, membrane slabs, and slabs-on-grade, cast against and permanently exposed to stabilized subgrade without plastic sheeting . . . . . 2.0 in. (50 mm)
- Formed surfaces and tops of footings, membrane slabs, and slabs-on-grade exposed to water . . . . . 1.5 in. (38 mm)
- Prestressed walls exposed to backfill, water, or weather . . . 1.5 in. (38 mm)
- Two-way prestressed roof slabs . . . . . 1.5 in. (38 mm)
- Beams and other members:
  - Primary reinforcement . . . . . 2.0 in. (50 mm)
  - Ties, stirrups, spirals . . . . . 1.5 in. (38 mm)
  - Anchorage (including clearance to waterstops) . . . . . 1.5 in. (38 mm)
  - Multistrand tail ends at anchorages . . . . . 2.0 in. (50 mm)
  - Plastic covers for monostrand tail ends . . . . . 1.0 in. (25 mm)
  - Pretensioned-strand tail ends in precast panels . . . . . 1.5 in. (38 mm)

3.11.2 *Nonprestressed concrete and shotcrete for domes.* For nonprestressed concrete and shotcrete domes, the following minimum covers shall be provided:

Bottoms of wall and column footings cast against and permanently exposed to stabilized subgrade . . . . .	2.0 in. (50 mm)
Formed surfaces of walls and footings, tops of slabs, bottoms of membrane slabs, and slabs-on-grade cast against and permanently exposed to stabilized subgrade . . . . .	2.0 in. (50 mm)
Tops of membrane slabs and slabs-on-grade, and bottoms of membrane slabs and slabs-on-grade cast against and permanently exposed to stabilized subgrade and plastic sheeting . . . . .	1.5 in. (38 mm)
Domes:	
No. 4 bars and smaller . . . . .	1.5 in. (38 mm)
No. 5 bars and larger . . . . .	2.0 in. (50 mm)
Beams and columns:	
Stirrups and ties . . . . .	2.0 in. (50 mm)
Primary reinforcement . . . . .	2.5 in. (63 mm)

### Sec. 3.12 Additional Considerations in Cold Climates

3.12.1 *Ice prevention.* When required by the purchaser, an ice-protection system shall be designed to prevent the tank water from freezing during the worst winter conditions anticipated during the service life of the structure (50 years, minimum).

Actual tank heat loss is dependent on the quality of the construction, whether or not it is buried, and airtightness of the insulation. Heat-loss calculations shall be made assuming a minimum tank water temperature of 2°C (36°F), unless more accurate data are available. Calculations shall be based on temperature-monitoring results of similar systems and materials.

3.12.2 *Buried tanks.* Concrete tanks may be protected from freezing by burying the tank, including earth cover over the roof.

#### 3.12.3 *Insulation.*

3.12.3.1 *Protection from freezing.* Concrete tanks may be protected from freezing by insulation and cladding on the exterior to reduce heat loss and to prevent significant internal ice formation. The thickness of the insulation may be specified by the purchaser when using inflated dome forms (ACI 334.3R), but not less than 1.5 in. (38 mm), and it shall become an integral part of the dome.

3.12.3.2 *Inspections and maintenance.* The cladding and insulation should be demountable to allow exterior inspections and maintenance.

3.12.4 *Mixing and heating.* Mixing and supplemental heating of the water in some tanks with low turnovers may be necessary for short periods during severe winters to supplement the heat-loss reduction by backfill or insulation.

The provision of heated air in the air gap between the insulation and the concrete is an alternative to mixing and heating the water where it is important that the concrete surface temperature does not fall to lower than freezing.

### **Sec. 3.13 Tank Appurtenances**

This section provides guidance to the purchaser in the functional aspects of tanks, including design for hydraulic considerations, operability, maintainability, security, and safety. The provisions of this section should be reviewed by the purchaser or purchaser's engineer and modified or incorporated as needed to suit special situations, practices, and requirements of governing agencies.

3.13.1 *Inlet and outlet piping arrangement.* Inlet and outlet piping should be designed to promote circulation of the stored water. Separate inlet and outlet pipes are recommended when practicable. Disinfectant contact time, disinfectant residual, and water quality are considerations in storage tank design and may require the use of baffles or directional inlets. This can be particularly important for large tanks or where the frequency of water volume turnover is insufficient to maintain water quality.

3.13.1.1 *Inlet.* The inlet pipe should have a valve outside the tank for maintenance or inspection.

3.13.1.2 *Outlet.* The outlet pipe shall be designed considering system hydraulic requirements and pipe-entrance head loss. A removable silt stop and, if determined necessary, a vortex breaking device are recommended to prevent scoured sediment from entering the outlet pipe.

Guardrails or other means of protection are recommended around large-diameter outlets for worker safety during periodic tank washdown and inspection.

3.13.1.3 *Encasement and flexible joints.* Reinforced concrete encasement of inlet–outlet piping placed under the floor slab is recommended for added corrosion protection. Flexible joints should be provided outside the footing and contraction/expansion fittings in vertical pipe penetrations to accommodate any movement caused by differential settlement or seismic activity.

3.13.1.4 *Exposed flanges.* An exposed flange on the inlet and outlet pipes within the tank is a desirable provision. In cases of pipe or valve leakage, blind flanges can be bolted in place to provide a complete shutoff, and can be important in locating the source of leakage for the watertightness test of the tank.

### 3.13.2 *Tank overflow and drain.*

3.13.2.1 **Overflow system.** The tank overflow system shall be designed to pass the maximum design inflow rate. Consideration should be given to the failure of flow- or pressure-limiting valves when quantifying the design inflow rate. The overflow weir, flared inlet pipe, or vortex breaker shall be sized to pass the design inflow rate at a maximum head equal to 75 percent of the freeboard between the weir elevation and lowest roof structural element, i.e., bottom of beams or the roof slab.

The overflow pipe should extend to a location where it can freely discharge without unacceptable consequences. The outlet pipe should terminate with a screen, reinforced elastomeric check valve, or flap gate, and for larger pipes, an outlet structure fitted with bar grating or a locking cover to prevent unauthorized entry. Riprap outfall protection or other means of energy dissipation may be required to limit velocity and erosion in the receiving drainage way.

3.13.2.2 **Washdown piping.** A washdown pipeline system inside the tank is desirable. Proper backflow prevention is essential in the design of a washdown pipe system. For large-diameter tanks, the washdown piping may be extended toward the tank center or around the inside of the tank perimeter. Washdown pipeline systems mounted on the wall of the tank shall consider wall movement from internal and external loads when applicable (such as in tanks with free-base walls). A floor slope to the drain will facilitate tank washdown.

3.13.2.3 **Tank drain.** A tank drain pipe is normally provided to drain off washdown and incidental water during inspection and cleaning. The drain line may be taken from the outlet pipe if it is located at the low point in the tank floor. The drain line must have a valve outside the tank and must terminate with a screen, reinforced elastomeric check valve, or flap gate. The receiving structure for the tank drain may also serve as the outlet structure for the overflow and the drain piping combined.

There may be circumstances where an underdrain system is required to prevent hydrostatic uplift under the tank floor when the tank is emptied. If the tank is subjected to hydrostatic uplift that cannot be relieved by a gravity drain system, observation wells and positive means of pumping down the water table to prevent buoyancy forces on the tank when drawn down must be provided. Discharging this drainage into a manhole where it can be measured may provide an effective means of monitoring leakage from the tank.

3.13.2.4 **Water level and quality.** A water-level gauge or a pressure sensor should be provided and calibrated to the depth of water in the tank to permit remote-level indication or recording. Sampling connections of suitable size for accurate monitoring of the quality of water in potable water tanks are also desirable features.

3.13.2.5 **Vents.** Vents should be provided to pass air at a flow rate equal to the maximum tank outflow rate in cubic feet per minute (cubic meters per second) at pressure differentials not over 0.5 in. (13 mm) of water column, and at velocities not exceeding 800 ft/min (27.8 m/sec).

The exhaust capacity of the vent must be at least equal to the design fill rate of the tank.

Vent screens should be protected from vandalism and unauthorized entry, but must be accessible for inspection and cleaning to remove insects or airborne lint, pollen, or dust. Where screens are subject to failure caused by icing, they should be designed to open, discharge air, and reclose at pressure differentials greater than 1 in. (25 mm) but less than 2 in. (50 mm) of water column, by means of springs and hinges or by other acceptable means.

On small tanks, 100 ft (30.5 m) in diameter or less, a single vent should be adequate. In larger tanks, multiple vents are recommended.

### 3.13.3 *Roof openings.*

3.13.3.1 **Roof openings.** Roof openings for appurtenances such as personnel hatches, equipment hatches, sample points, and vents should be constructed to prevent leakage into the tank and should have padlocking or other security measures to resist unauthorized entry or vandalism. If possible, they should be placed where they are easily visible.

Roof openings should be atop curbs at least 4-in. (100-mm) high. Covers should turn down at least 2 in. (50 mm) over the curbs or should be provided with drain troughs in the frames. Frames and covers should be galvanized steel, stainless steel, or aluminum at least  $\frac{3}{16}$ -in. (5-mm) thick. Personnel hatches shall be at least 30-in. (0.75-m) square and provided with protective handrails conforming to OSHA requirements. Where access is needed to hatches, sample points, or vents over 5 ft (1.5 m) above grade, or where icing conditions may occur, handrails and steps should be provided.

3.13.3.2 **Temporary roof openings.** Temporary roof openings to facilitate construction and removal of formwork and equipment hatches for inspection and



maintenance should be at least 4 ft × 6 ft (1.2 m × 1.8 m) or greater, as required for special needs.

3.13.4 *Ladders and stairs.* Access ladders and stairs shall conform to OSHA requirements. Ladder rungs and stair treads should have a nonslip surface. Rung spacing shall not exceed 12 in. (300 mm). Rung and tread spacing shall be uniform throughout the length of the ladder or staircase. The distance from the floor or landing to the bottom rung of inside ladders and rise-to-run ratios on stairs should conform with OSHA or locally adopted code requirements.

Ladder stringers should be punched to receive rungs. Rungs and brackets should be welded to stringers. Stringers should be at least  $\frac{3}{8}$  in. × 2 in. (10 mm × 50 mm), and rungs should have a diameter (if round) or width (if square) of at least  $\frac{3}{4}$  in. (20 mm). Brackets may be made of the same bar size as the stringers. Ends of ladder stringers should be rounded.

Exterior ladders should be provided with security provisions to limit access, or terminated at least 12 ft (3.7 m) above the ground to discourage unauthorized access.

Galvanized steel, stainless steel, aluminum, or fiber-reinforced plastic are recommended for construction materials.

A cage, harness, or other acceptable fall protection device is recommended and shall be provided when ladder heights exceed OSHA prescribed requirements.

Stairs shall be fitted with handrails and landings at intervals specified by OSHA.

---

## SECTION 4: EARTHQUAKE DESIGN CONSIDERATIONS

---

### Sec. 4.1 Introduction

4.1.1 *Analysis and design.* The seismic analysis for tendon-prestressed concrete tanks may be the effective-mass method or a more accurate analysis method for seismic loads (see appendix A, Bibliography). The effective-mass method recognizes the reduction in seismic load caused by the sloshing of a portion of the contained liquid. The analysis shall be in accordance with ACI 350.3, as modified herein.

The user of this standard is directed to appendix A for references providing background on the theory of plates and shells and for other general reference

**Table 1 Response modification factor,  $R$ , for type of tank base**

Type of Base	$R_i$		$R_c$
	On or Above Grade	Below Grade	
(a) Fixed-base tanks, Figure 2A	3.5	4.5	1.4
(b) Hinged-base tanks, Figure 2B	2.8	3.5	1.4
(c) Anchored flexible-base tanks, Figure 2C	2.1	2.7	1.4
(d) Unanchored, contained or uncontained tanks, Figures 2D and 2E	1.5	2.0	1.4

NOTE: The above  $R$  factors give "Working Loads" for seismic design. If using "Strength Design" as in Section 9.2.1 of ACI 350-06, multiply load effects derived from these factors by 1.4.

material commonly used in the design of liquid-containment structures subjected to earthquake-induced forces. The design should be in accordance with ACI 350, as modified herein.

4.1.2 *Design coefficients and factors.* Design coefficients and factors to be used in conjunction with the applicable sections of ACI 350 and ACI 350.3 are found in those documents, except use the response factors listed in Table 1 for use with the working stresses of Section 3 of this standard.

4.1.3 *Notation.* The notation used in the various equations presented in Section 4 is defined as follows:

$D$  = inside tank diameter, in ft (m)

$f_{ult}$  = specified ultimate tensile strength of strand for restraint cable, psi (Pa),  
Sec. 4.6.1

$M$  = combined overturning moment applied to the bottom of tank shell, in  
lb-ft (N-m), Sec. 4.8.1

$R$  = inside radius of tank wall, in ft (m)

$S_1$  = mapped maximum considered earthquake, 5 percent damped, spectral  
response acceleration at a period of 1 second, expressed as a fraction of  
the acceleration due to gravity,  $g$ , from ASCE 7-05, Figures 22-1  
through 22-14

$S_{DS}$  = design earthquake spectral response acceleration, 5 percent damped, at  
0.2-sec period, stated as a fraction of the acceleration due to gravity,  $g$

$S_S$  = mapped maximum considered earthquake, 5 percent damped, spectral  
response acceleration at short periods, expressed as a fraction of the  
acceleration due to gravity,  $g$ , from ASCE 7-05, Figures 22-1 through  
22-14

$T_v$  = natural period of vibration of vertical liquid motion, in seconds,  
Sec. 4.5.1

$\ddot{u}_v$  = vertical acceleration, in  $g$ , Sec. 4.5.1

$V_T$  = total base shear at the bottom of the tank shell, in lb (N), Sec. 4.3.1.1

$W_S$  = total weight of the tank wall (shell), in lb (N)

$w_t$  = weight of the tank, in lb/ft (N/m) of shell circumference, Sec. 4.4.6

$\mu$  = coefficient of friction, Sec. 4.7

## Sec. 4.2 Seismic-Design Categories

4.2.1 *Wall–base joint types.* For purposes of seismic design, concrete tanks can be classified into five types of joints between the wall and the foundation (types A, B, C, D, and E):

4.2.1.1 *Nonsliding bases (types A and B).* Tanks with this type of base have a fixed (type A, Figure 2A) or hinged (type B, Figure 2B) joint between the wall and the foundation. These types of walls are tied to the footings and floors by steel reinforcement or keying action after application of the horizontal prestressing.

4.2.1.2 *Anchored flexible base (type C).* Tanks with this type of base have an anchored flexible joint between the wall and the foundation; anchorage is achieved with strand cables embedded in the wall and in the footing, as shown in Figure 2C, which resist tangential movements but not radial movements of the wall. This type of joint is only applicable to circular prestressed-concrete tanks.

4.2.1.3 *Unanchored and uncontained flexible base (type D).* Tanks with this type of base have an unanchored and uncontained flexible joint between the wall and the foundation; flexibility is achieved by an elastomeric bearing pad (Figure 2D). This type of joint is only applicable to circular prestressed-concrete tanks and shall not be used in any of the higher seismic regions ( $S_{DS} > 0.50$ ).

4.2.1.4 *Unanchored and contained flexible base (type E).* Tanks with this type of base have an unanchored joint contained by a concrete curb (Figure 2E). This type of joint is only applicable to circular prestressed-concrete tanks and shall not be used in high seismic regions ( $S_{DS} > 0.50$ ) where uplift is expected of the wall bottom.

4.2.2 *Wall-to-roof joint connection.* Any of the categories of tanks described in Sec. 4.2.1 may have, at the wall-to-roof connection, a joint that is monolithic, or that has flexible or rigid ties, or that has no ties (elastomeric pad only). A joint with an elastomeric pad and without ties shall be contained to preclude excessive lateral displacement between the roof and the wall. Tanks in high seismic regions ( $S_{DS} > 0.50$ ) and tanks having an importance factor greater than

unity shall have provisions that prevent the upward displacement of the roof with respect to the wall caused by the height of the sloshing wave and vertical accelerations (see Sec. 4.10) unless sufficient freeboard is provided to prevent uplift.

### Sec. 4.3 Seismic-Design Loads

4.3.1 *Effective-mass procedure for determining base shear and overturning moment caused by seismic effects.* The effective-mass procedure considers two response modes of the tank and its contents: (1) the impulsive mode, which is the high-frequency amplified response to lateral ground motion of the tank shell and roof together with that portion of the liquid contents that moves in unison with the shell, and (2) the convective mode, which is the low-frequency amplified response of a portion of the liquid contents in the fundamental sloshing mode. The analysis requires the determination of the hydrodynamic mass associated with each mode and the lateral force and overturning moment applied to the shell resulting from the response of the masses to lateral ground motion. Because the two different response modes are not maximized at the same time, the root-mean-square can be used for combining forces and moments resulting from the two response modes.

4.3.1.1 Lateral or horizontal base shear. The lateral or horizontal base shear caused by seismic forces applied at the bottom of the tank wall shall be determined as required in the applicable sections of ACI 350.3.

In the case of type A and type B bases in circular tanks (see Sec. 4.2.1), the wall design shall provide for the amount of base shear  $V_T$  to be transferred radially and tangentially as determined by rational analysis. One means of providing for this base shear in a pinned base tank is shown in Figure 4. In addition to providing for the appropriate percentage of the base shear to be transferred tangentially as noted, for type A and type B bases, the maximum lateral or radial base shear at 0 degrees from the direction of the earthquake, along with the corresponding vertical bending moments and, when applicable, hoop forces, shall also be provided for, in accordance with Sec. 4.5.3.

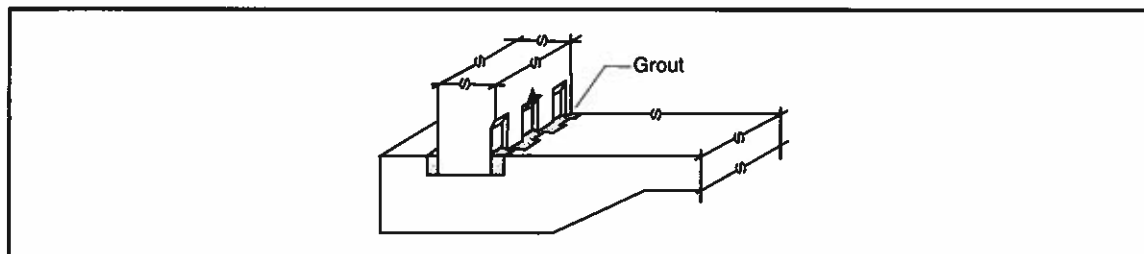

Figure 4 Transfer of tangential shear from wall to base

In the case of type C bases with diagonal seismic cables between the footing and the wall, the wall design shall provide for 100 percent of the base shear to be transferred tangentially. In addition, for type C bases in circular tanks, the maximum hoop forces at 0 degrees from the direction of the earthquake shall also be provided for in accordance with Sec. 4.5.3.

Circular tanks with type A, type B, and type C bases shall be designed for a peak tangential shear of  $V_T/\pi R$  at 90 degrees from the direction of the earthquake.

Type D bases shall be designed for the same unit tangential shear as for type A, type B, and type C bases but shall not be used in the higher seismic regions, as noted above.

Type E bases shall be designed for radial shear only, with the maximum radial shear being  $V_T/\pi R$ . This radial shear shall be added to or subtracted from the radial shear as determined in Sec. 4.5.3, if any.

4.3.1.2 *Overturning moment.* The analysis of and design for overturning moment caused by seismic forces applied at the bottom of the tank wall shall be determined as required in the applicable sections of ACI 350.3 and ACI 350, respectively.

## Sec. 4.4 Vertical and Horizontal Forces

4.4.1 *Application at joints.* Wall–roof joints and wall–floor joints shall be designed to resist the horizontal and vertical forces they transmit caused by the earthquake and gravity loads acting simultaneously.

4.4.2 *Effects on tank components.* Roofs, walls, and floors shall be investigated for strength and stability under tensile and compressive axial or hoop forces, vertical bending moments, lateral or radial and longitudinal or tangential shear forces, and overturning moment resulting from earthquake-induced impulsive and convective forces and from gravity loads acting simultaneously. For circular tanks, the impulsive and convective forces shall be converted to their maximum pressures based on a cosine distribution, and these maximum pressures shall be used to analyze the wall as though the pressures were axisymmetric for purposes of finding the maximum hoop forces. In circular tanks with base type A or type B, as per Sec. 4.2.1, these same equivalent axisymmetric hoop loads shall be used to find the radial shear and vertical bending moments (see Sec. 4.5.3). This procedure recognizes that the cosine distribution is relatively flat in the peak pressure zone.

4.4.3 *Seismic cables.* For circular tanks with type C bases (see Sec. 4.2.1), the strength of seismic cables and their anchorage in the tank wall and foundation

shall also be investigated under tensile forces resulting from earthquake-induced base shear and overturning moment.

**4.4.4 Base-pad design considerations.** For tanks with type C, type D, and type E bases (see Sec. 4.2.1), the strength of base pads shall also be investigated under shear and compressive forces resulting from earthquake-induced base shear and overturning moment and from gravity loads acting simultaneously. The base pads for tanks with type D bases shall be designed to resist the total earthquake-design base shear. Maximum total base-pad frictional resistance shall not exceed the limits required in the applicable sections of ACI 350 and ACI 350.3 unless adequate shear keys or other positive mechanical means of attachment are provided to transfer the shear forces from the concrete to the base pads. Furthermore, such friction calculations shall consider vertical accelerations that can reduce gravity dead loads.

**4.4.5 Contained flexible base design.** For circular tanks with type E bases (see Sec. 4.2.1), the strength of the containment pad, the containment pad support structure, and the tank wall shall be investigated under forces resulting from the impulsive and convective forces.

**4.4.6 Vertical forces at wall base.** The maximum and minimum vertical forces at the bottom of the tank wall caused by earthquake-induced overturning moment shall be determined as required in the applicable sections of ACI 350.3.

The weight of the tank,  $w_t$ , in pounds per foot of shell circumference shall be determined.

Hold-downs shall be provided for any net uplift calculated for the tank.

**4.4.7 Cable anchorage force.** The maximum vertical compressive force at the bottom of the tank wall caused by gravity load and earthquake-induced base shear in circular tanks with type C bases (see Sec. 4.2.1) shall include the vertical component of force in the anchor cables in resisting the tangential shear.

## Sec. 4.5 Other Effects

**4.5.1 Vertical acceleration.** The tanks shall be designed for vertical acceleration. Unless the use of a greater vertical acceleration is specified or agreed to by the purchaser, the vertical acceleration,  $\ddot{u}_V$ , shall be determined as required in the applicable section of ACI 350.3. Where no site-specific vertical acceleration is given, the vertical acceleration shall be no less than  $\frac{2}{3}$  of the horizontal acceleration. The natural period of vibration of vertical liquid,  $T_v$ , shall be determined as required in the applicable sections of ACI 350.3.

4.5.2 *Combining acceleration effects.* The strength and stability of walls, floors, and roofs shall be adequate to withstand the effects of both the design horizontal acceleration and the design vertical acceleration. Effects of maximum horizontal and vertical acceleration shall be combined by the root-sum-square method.

4.5.3 *Equivalent axisymmetric hoop loads.* In circular tanks, hydrodynamic seismic membrane hoop tensile stresses in the circumferential direction, radial shear, and vertical bending moments shall be determined by applying the maximum radial pressure as an “equivalent axisymmetric hoop load” as caused by the response of the mass of the tank shell (wall), combined with the maximum radial pressure caused by the response of the mass of the tank contents to the tank wall, taking boundary conditions into account. The designer is also advised to take uncertainties in the base restraints into account, such as “enveloping” of the design for fixed-base tanks for some partial release of rotational restraint at the base of the wall. The equivalent axisymmetrical hoop loads, summed over the full height of the tank wall (see Sec. 4.5.4 for the vertical distribution of these loads), for each component should be determined as required in the applicable sections of ACI 350.3. For circular tanks, the maximum equivalent axisymmetrical hoop load, at any elevation on the tank wall for each component, may be obtained by multiplying the maximum radial pressure at that elevation by the radius.

4.5.4 *Vertical distribution of seismic pressure.* The vertical distribution of the impulsive and convective water pressure, resulting from the response of the tank contents, shall be determined according to the applicable sections of ACI 350.3.

## Sec. 4.6 Allowable Stresses

4.6.1 *Seismic-cable stress.* Maximum seismic-cable tensile stress shall not exceed  $0.75 f_{ult}$ , where  $f_{ult}$  is the specified ultimate tensile strength of the strand for the restraint cable.

4.6.2 *Base pad and containment pad.* Maximum base-pad and containment-pad shear and compressive stresses shall not exceed the limits for occasional loading recommended by the manufacturer. The minimum width-to-thickness ratio for pads and the minimum length-to-thickness ratio for discontinuous pads shall be 3:0. The net effective pad width after shear deformation (Figure 5) shall be used to compute the maximum compressive stress on the base pad.

4.6.3 *Concrete.* See Sec. 3.4.1 for allowable concrete stresses for the design earthquake.

4.6.4 *Nonprestressed reinforcement.* See Sec. 3.4.3.2 for allowable nonprestressed reinforcement stresses for the design earthquake.

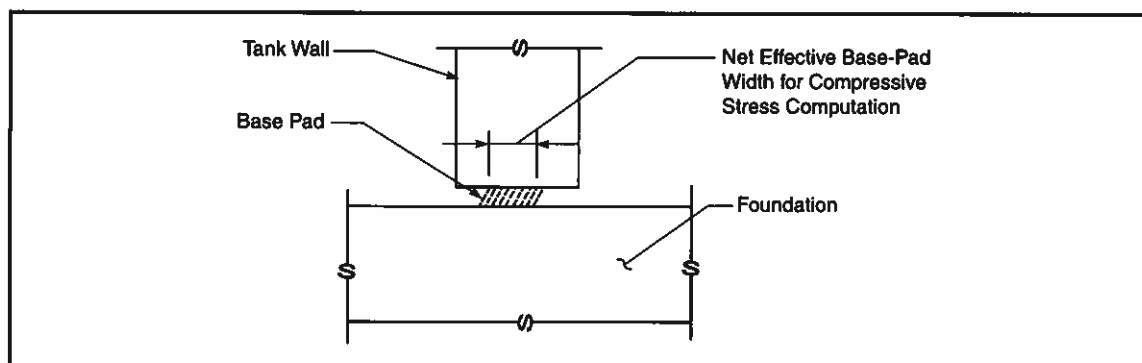

Figure 5 Net effective base-pad width after shear deformation

#### Sec. 4.7 Maximum Allowable Coefficient of Friction

The coefficient of friction,  $\mu$ , between concrete and an elastomeric pad in a circular tank with bearing pads shall not be taken larger than 0.5 to compute maximum allowable base-pad service load frictional resistance. Friction between the bearing pad and the wall base shall not be relied on to reduce the tangential displacement of the wall base in the higher seismic regions ( $S_{DS} > 0.50$ ).

#### Sec. 4.8 Serviceability Requirements

4.8.1 *Uplift limitation.* Tanks without vertical or diagonal ties between the wall and footing shall not be permitted to have tension caused by uplift from earthquake-induced overturning moment. For no uplift, the overturning moment,  $M$ , must be less than or equal to  $0.785WS_D^2$ .

4.8.2 *Waterstop integrity.* For circular tanks with type C or type D bases (see Sec. 4.2.1), the relative displacement between the tank shell and the foundation caused by the combined effects of earthquake-induced base shear, gravity loads, and vertical accelerations shall not exceed the capability of the waterstop to accommodate radial and tangential movement without leakage. Friction between the bearing pad and the wall base shall not be relied on to reduce the tangential displacements of the wall base in high seismic regions ( $S_{DS} > 0.50$ ).

4.8.3 *Anchor cable sleeves.* For circular tanks with a type C base (see Sec. 4.2.1), compressible sleeves shall be used over the anchor cable at the base joint to allow radial wall movement.

4.8.4 *Containment-pad thickness.* For circular tanks with type C and type D bases (see Sec. 4.2.1), the thickness of the flexible containment pad shall be not less than 1.5 times the computed total horizontal displacement of the tank base for hydrostatic and seismic loading.



## Sec. 4.9 Foundation Design

4.9.1 *General.* Foundations shall be designed to resist simultaneous application of gravity loads and the horizontal and vertical forces caused by seismic design forces induced by the design earthquake. Foundations for anchored tanks (base types A, B, or C) shall be designed to resist the anchor uplift forces, if any, resulting from the earthquake-induced overturning moment and gravity loads acting simultaneously. Foundations for tanks shall be designed to resist the compressive forces resulting from the earthquake-induced overturning moment and gravity loads acting simultaneously.

4.9.2 *Soil stress.* A onethird increase in allowable soil stresses is permitted for load combinations that include seismic loads.

4.9.3 *Overturning moment.* The overturning moment in Sec. 4.3.1.2 is that applied to the base of the tank shell. The foundation is subjected to an additional moment caused by the sloshing of the tank contents and the effect of dynamic fluid pressure on the tank bottom as well as an additional moment equal to the base shear times the vertical distance between the shell base and the result of the lateral soil load on the foundation. Overturning of the tank shall be prevented by limiting the soil pressure, as noted in Sec. 4.9.2, with a safety factor of not less than 1.5.

## Sec. 4.10 Minimum Freeboard

During a seismic event, the maximum water-surface displacement (sloshing height) may impinge on the underside of the roof slab. The anticipated unrestrained sloshing height, computed in accordance with ACI 350.3, shall be determined for tanks. If a freeboard height is not provided to prevent uplift forces caused by sloshing, the tank roof and its connections shall be designed for the uplift forces. The uplift forces generated by the restraint of sloshing shall be computed as the hydrostatic force produced by the liquid restrained from sloshing. The connection of the roof to the wall shall be designed for the resulting forces.

## Sec. 4.11 Design for Seismic Effects of Backfill

The dynamic seismic forces caused by the backfill surrounding the tank, if any, shall be taken into account according to the soil–structure interaction criteria given by the geotechnical engineer.

In a buried tank, the dynamic backfill forces shall not be relied on to reduce the dynamic effects of the water in the tank.

---

## SECTION 5: CONSTRUCTION PROCEDURES

---

### Sec. 5.1 Scope

The requirements for placing, finishing, and curing concrete shall be in accordance with ACI 350.5, ACI 302.1R, ACI 304R, ACI 305R, ACI 306.1, ACI 308R, ACI 334.3R, ACI 350, ACI 506R, and ACI 506.2 as modified herein, and additional requirements related to tendon-prestressed concrete construction not included in these references.

### Sec. 5.2 Cast-in-Place Concrete

#### 5.2.1 *Forming.*

5.2.1.1 General. Formwork shall meet the requirements of ACI 347R and ACI 350.5, unless modified by the purchaser in the project specifications. For circular tanks and curved portions of other configurations, wall forms shall be fabricated such that straight chords caused by use of panel forms do not exceed 24 in. (600 mm) in length.

5.2.1.2 Wall-form ties. Form ties that remain in the walls shall be designed to prevent seepage or flow of water along the embedded tie, in accordance with ACI 347R. Ties with snug-fitting rubber washers or O-rings have been found to be generally acceptable for this purpose. Tie ends shall be recessed in concrete at least 1 in. (25 mm). The holes shall be cleaned and, when applicable, coated with an epoxy bonding agent and filled with nonshrink grout of strength equal to or greater than the concrete. Taper ties may be used when tapered vinyl plugs and grout are used to fill the cleaned voids created by the ties. When tapered ties are used, the larger diameter of the taper shall be on the inside face of the wall. If tapered ties are used, the holes shall be cleaned by sandblasting or wire brushing to remove bond breaker or laitance. The holes shall be vinyl-plugged and coated with epoxy bonding agent and dry-packed with nonshrink grout in accordance with this standard. The inside wall surface of the hole and the dry-packed surface of the interior wall shall be coated with a 10-mil (254- $\mu\text{m}$ ) minimum thick layer of moisture-insensitive epoxy.

5.2.1.3 Dome-roof forms. Dome forms shall be designed to resist forces acting with respect to their sloped surfaces. The bracing required will be determined by the sequence of concrete or shotcrete placement and the rate at which it is placed. It is important to maintain proper curvature of the shell to avoid flat spots. Except for the outermost set of forms and ribs, formwork for concrete or shotcrete

domes shall not be removed until the concrete or shotcrete is of sufficient strength and until a circumferential prestressing force sufficient to support the dead load and a nominal live load has been applied to the dome's tension ring.

### 5.2.2 *Construction joints.*

5.2.2.1 *Review.* Prior to the start of construction, the constructor shall submit for review layouts and details of proposed joints in floors, footing pads, walls, and roofs, unless these details are indicated on the contract drawings.

5.2.2.2 *Requirements.* Spacing of vertical construction joints in cast-in-place concrete walls should consider the contractor's ability to place the concrete without honeycombing or cold joints. Continuous reinforcement shall be used in the joint to prevent lateral displacement of adjacent wall panels or sections prior to prestressing. Shear keys are generally not required or recommended in floors or wall construction joints. Details of joints shall be indicated on the contract drawings. Joints between any two adjacent elements of the floor, wall, wall footing, or roof, or joints between the floor and wall or between the wall and its footing, shall contain a waterstop.

5.2.3 *Nonprestressed steel reinforcement.* Nonprestressed steel reinforcement shall be stored, handled, and placed in accordance with ACI 350.5.

### 5.2.4 *Prestressing tendons.*

5.2.4.1 *General.* Storing, handling, and placing of prestressing tendons shall meet all construction requirements set forth in ACI 350.5, the *PTI Manual for Certification of Plants Producing Unbonded Single Strand Tendons*, and *PTI Field Procedures Manual for Unbonded Single Strand Tendons* as applicable. Prestressed reinforcement shall be stored on dunnage, off the ground, and protected to prevent moisture from unduly corroding the steel. A light coat of rust is permissible, provided loose rust has been removed and the surface of the steel is not pitted. Under no circumstances should prestressed reinforcement be allowed to sit in standing water or mud. Strand or bars showing signs of corrosion shall not be installed.

5.2.4.2 *Supervisor qualifications.* Installation and field handling of tendons and associated stressing and grouting shall be under the direction of a supervisor who has PTI Levels 1 and 2 Unbonded PT Ironworker Certifications for tanks with unbonded tendons and PTI Levels 1 and 2 Bonded PT Field Specialist Certifications for tanks with bonded tendons. The supervisor shall also have technical knowledge of prestressing principles, and five years' qualifying experience

with the particular system or systems of post-tensioning being used. The supervisor for all grouting operations shall also be an ASBI\* Certified Grouting Technician.

5.2.4.3 Installation. When the duct is to be filled with grout, the nominal internal area of the duct shall be a minimum of 2.25 times that of the prestressing strand cross-sectional area and 2.5 times the cross-sectional area for tendons placed by the pull-through method. If for any reason the duct-to-steel area ratio falls outside the given limits, it shall be shown by tests that proper grouting, corrosion protection, and bond transfer are possible.

For tendons composed of single prestressing bars, the minimum internal duct diameter shall be at least 0.25 in. (6 mm) larger than the outside diameter (maximum dimension) of the prestressing bar.

If the duct is to contain tendons individually coated with seamless extruded sheathing, it shall be of sufficient size to permit the installation of the tendons. Ducts for internal tendons shall be securely fastened to prevent distortion, movement, or damage from placement and vibration of the concrete. Ducts shall be supported as required to control wobble (consistent with the design parameters). After installation in the forms, the ends of the ducts shall be covered as required to prevent the entry of mortar, water, or debris. Ducts and duct connections shall be inspected prior to concreting to help prevent mortar leakage or indentations that would restrict movement of the prestressed reinforcement during the placing or stressing operation. Where ducts may be subject to freezing prior to grouting, drainage shall be provided at any intentional low points to prevent blockage or damage from freezing water. Additional precautions, such as keeping the wall temperature above freezing, may be required in extreme cold-weather situations. The minimum clear spacing between ducts shall not be less than 2 in. (50 mm), two times the maximum size of aggregate, or the diameter of the duct, whichever is greater.

Unbonded single-strand tendons shall be installed by placers, a minimum of half of which shall be PTI Level 1 Unbonded PT Ironworker certified, and shall be installed in accordance with the PTI *Field Procedures Manual for Unbonded Single Strand Tendons*. The tendons shall be tied to supports as required to control wobble (consistent with the design parameters), but at least every 4 ft (1.2 m). Care, such as handling with nylon slings or padded forklifts, shall be taken to prevent tears in sheathing. Any tears shall be repaired by waterproof taping.

---

\* American Segmental Bridge Institute, 142 Cimarron Park Loop, Suite F, Buda TX 78610-2837.

5.2.4.4 Tensioning of tendons. Tendons are tensioned by means of hydraulic jacks. Jacks and gauges shall be calibrated by a testing laboratory.

Prior to post-tensioning, the prestressed reinforcement shall be free and unrestricted.

Concrete strength at the time of stressing shall be in accordance with Sec. 3.4.1. It shall also be sufficient to sustain the concentration of bearing stress under anchorage plates without damage, as required in ACI 350. The stressing strength shall be confirmed by pullout tests (ASTM C900), maturity meters, or field-cured cylinders.

The vertical tendons, if any, shall be tensioned first. Staged stressing, such as stressing every fourth tendon initially, then stressing the remainder, is recommended.

The horizontal tendons shall be tensioned in a sequence that will be as symmetrical as practical about the tank's axis. This generally involves alternating sides of the buttress (in buttress tanks) as tensioning proceeds and alternating buttresses to achieve symmetry; alternatively, stressing points making up the entire circumference at one elevation may be stressed simultaneously. Stress every fourth tendon and then stress the remainder. The prestressing sequence required by the design should be detailed on the post-tensioning shop drawings.

Tendon elongations, calculated by the post-tensioning supplier, shall be indicated on the shop drawings. These shall include a method of removing and/or accounting for the slack in the tendons. A force and elongation reading for every jacking point shall be made for each tendon.

The measured elongation for each tendon and the calculated elongation shall be resolved in accordance with the provisions of ACI 350 except as modified herein. Adding the measuring tolerance,  $\frac{1}{8}$  in. (3 mm), to the allowable tolerance is generally considered acceptable for short tendons, such as vertical wall tendons. Tendons with less than 95 percent of the calculated elongation shall be restressed once. Elongations greater than 107 percent of the calculated elongation should be reviewed and are usually because of underestimation of the modulus of elasticity or friction values. When this situation occurs, the tendons may not need to be detensioned and restressed. Observed forces and elongations are to be recorded and made a part of purchaser's file.

5.2.4.5 Grouting. Upon completion of concrete placement and initial set, ducts may be checked for damage and obstructions by passing a suitable torpedo of rigid material through them. The torpedo shall have the same cross-sectional shape as the duct and be  $\frac{1}{4}$ -in. (6-mm) smaller than the clear nominal inside dimensions of the duct as given on the installation drawings. The torpedo length shall

reflect the expected duct curvature while maintaining the ¼-in. (6-mm) clearance requirement. The torpedo shall pass through the duct easily when pulled by hand, without requiring excessive effort or mechanical assistance.

Grouting of tendon ducts should be performed as promptly as possible after tensioning. Prestressing steel for bonded tendons shall not be exposed in ducts for longer than the time intervals specified in the PTI/ASBI M50.3 *Guide Specification for Grouted Post-Tensioning*. If grouting is to be delayed beyond the time intervals specified, additional temporary corrosion protection measures shall be taken in accordance with PTI/ASBI M50.3. The methods or products used shall not jeopardize the effectiveness of the grout as a corrosion inhibitor nor the bond between the prestressed reinforcement and the grout. Additional restrictions may be appropriate for potentially corrosive environments.

Grouting equipment shall be capable of grouting at a pressure of 200 psi (1.4 MPa). However, the tendon ducts should not be over-pressurized during injection if blockage exists. Instead, the grout should be washed out and the blockage removed. Inlets shall be used for injecting the grout into the duct; outlets shall allow the escape of air, water, grout, and bleed water. The inner diameter of both outlets and inlets shall be at least ¾ in. (20 mm) for strand tendons and ⅝ in. (10 mm) for single-bar tendons. The length shall extend sufficiently out of the concrete member to allow proper closing of the outlets.

Inlets and outlets shall be placed: (a) at the anchorage area of the tendon; (b) at the high points of the duct when the vertical distance between the highest and the lowest point is more than 20 in. (0.5 m); (c) at or near the lowest point of a tendon (inlet only); (d) at low points, and shall be free draining (outlets only); (e) at major changes in the cross section of the duct, such as couplers and anchorages; and (f) at other locations recommended by the purchaser or tendon supplier.

An additional grout outlet should be provided within a short distance (less than 3 ft [1 m]) downstream of a high point outlet. After the grout has set, but not less than 24 hours after grouting, cut off any vents or stand pipes and seal.

Grout injections for vertical tendons shall always be from the lowest point in the tendon to avoid entrapping air.

Grout specifically made for tendons with thixotropic admixtures shall be used to prevent bleeding and grout settlement in vertical tendons and horizontal tendons.

Grout should pass through a screen with 0.125-in. (3-mm) maximum clear openings before being introduced into the grout pump.

When quick setting can occur because of hot weather, the grout should be cooled by acceptable methods, such as cooling the mixing water, to prevent blockages during pumping operations. When freezing weather conditions prevail during and following the placement of grout, adequate means, such as maintaining the wall temperature with heaters or blankets, shall be provided to protect the grout in the ducts from freezing until the grout attains a minimum strength of 1,000 psi (7 MPa).

5.2.4.6 Protection of post-tensioning anchorages. Anchorages shall be protected by one of the following methods:

5.2.4.6.1 Recessed-end anchorages shall be dry-packed with nonshrink cement mortar. At least the minimum cover set forth in Sec. 3.11 shall be provided. To help ensure bonding, the concrete surfaces against which concrete encasement over anchorage assemblies is to be placed shall be cleaned of rust and laitance. An epoxy bonding agent, meeting the requirements of Sec. 2.8, shall be used before the mortar is placed.

5.2.4.6.2 If continuous vertical concrete caps are placed over the end anchorages of the horizontal tendons, the caps shall be secured by ties or anchors to the buttress. The forms for these caps shall be mortar-tight and fastened solidly to the tank wall and buttresses to prevent grout leakage. The maximum-size aggregate shall be  $\frac{3}{8}$  in. (10 mm). The concrete shall be vibrated to ensure compaction and complete encapsulation around the end anchorages. At least the minimum concrete cover set forth in Sec. 3.11 shall be provided.

5.2.4.6.3 In-line anchorages or couplers for multistrand tendons may be protected with pumped shrinkage-compensating grout, dry-packed mortar as described herein, or vertical precast concrete covers. Precast concrete covers, if used, shall be placed over the recessed area where the anchorages of the horizontal tendons are exposed. This cover shall be made of dense precast concrete with a minimum of 28-day compressive strength of 4,000 psi (28 MPa). Multiple sections may be used depending on the height of the tank. The precast covers shall be bolted to the tank. Joints between the precast segments and between precast segments and the wall shall be sealed with the use of nonshrink grout. The anchorage assembly and internal unbonded tendons shall be protected to eliminate exposure to the atmosphere.

#### 5.2.5 *Weather limitations.*

5.2.5.1 Cold weather. Unless specific preparations are made, concrete shall not be placed during cold weather. When the ambient temperature is

expected to be below 35°F (2°C), before the concrete compressive strength reaches 500 psi (3.5 MPa), preparations shall be made to properly protect the concrete. Most well-proportioned concrete will reach this strength when the temperature has been maintained at 50°F (10°C) into the second day after placement. Cold-weather concreting shall be in accordance with ACI 306.1 and ACI 350.5. The materials shall be heated so that the temperature of the concrete, when deposited, shall not be less than 55°F (13°C), or as otherwise indicated in ACI 306.1, or more than 70°F (21°C).

When using the inflated form method for dome construction (ACI 334.3R), maintain an interior temperature of 40°F (5°C) or higher until shotcrete strength reaches 1,000 psi (7 MPa).

Methods and equipment for heating and for protecting concrete in place should be reviewed by the purchaser.

**5.2.5.2 Hot weather.** During hot weather, concreting shall be in accordance with the provisions of ACI 305R. For concrete placed during extremely hot weather, the aggregate shall be cooled by frequent spraying in such a manner as to use the cooling effect of evaporation. During such periods, an acceptable placement schedule shall be arranged in a manner as to provide time for the temperature of the previously placed course to begin to drop.

**5.2.5.3 Curing.** When large surface areas, such as floors or roofs, are to be finished, surfaces exposed to drying winds shall be covered with polyethylene sheets or membrane-curing compound immediately after finishing and shall be water cured by ponding or by covering with polyethylene sheets continuously from the time the last of the concrete placed has taken its initial set. Curing compounds may be used instead of water curing for roof slabs, provided they are compatible with any coating that may be later applied. Curing compounds shall not be permitted instead of water curing for floor slabs. For potable water tanks, curing compounds used on interior floor and wall surfaces shall not impart taste or odor to the water, shall be certified as suitable for this use in accordance with NSF/ANSI 61 or other applicable governmental regulatory agency, or shall be fully removed before the tank's use.

#### *5.2.6 Placing of concrete.*

**5.2.6.1 Floors.** Concrete-membrane floors shall be cast continuously, without cold joints and, where practicable, without construction joints except as provided for in Sec. 3.7.9. Structural floors shall be cast continuously in sections of



such size that once any placement begins, it will be completed without interruption. Thickening the floor slab at the joint to a minimum of 8 in. (200 mm) will facilitate proper placement of the waterstop, but it may also contribute to shrinkage stresses that will require additional steel reinforcement in the thickened section as per Sec. 3.6. Top floor surfaces shall be to the line and grade specified. Unless otherwise specified, the floor shall be power-float finished.

5.2.6.2 Cast-in-place walls and columns. Cast-in-place walls and columns shall be placed in accordance with the requirements of ACI 350.5 or ACI 304R. Tank wall sections and columns shall be placed in a single, continuous operation, without horizontal joints, except as specifically provided for in the design.

The forms shall be cleaned and coated with nonstaining, nontoxic form release oil before each placement of concrete, as specified in ACI 350.5.

Concrete shall not be placed until reinforcement is securely fastened in position and until sleeves, hangers, pipe, bolts, ducts, tendons, and other items required to be embedded in the concrete have been placed and anchored.

A neat-cement grout or 1:1 cement-sand slurry can be used at the base of the wall to improve embedment of the horizontal base waterstop. The neat-cement grout or cement-sand slurry, if used, should be placed to a level not less than 1 in. (25 mm) nor more than 2 in. (50 mm) above the top of the waterstop and shall be properly vibrated into the subsequently placed concrete. The tops of the PVC waterstops shall be adequately laterally supported to prevent displacement during the initial concrete placement. A fine aggregate mix may also be used at the base of the wall for embedment of the reinforcement and bottom anchorages of vertical prestressing tendons.

Concrete shall be conveyed from the mixer to the forms by methods that will avoid segregation or loss of ingredients. Concrete shall be deposited, as nearly as practicable, to its final position horizontally. Vibrators shall not be used to transport concrete laterally. There shall be no free vertical drop greater than 6 ft (2 m); furthermore, when starting a wall placement, the free vertical drop shall not exceed 4 ft (1.2 m).

Self-consolidating concrete (SCC) may also be used in tank walls. SCC shall not be aggressively vibrated; however, care shall be taken to avoid honeycombing and lift lines.

Concrete shall be placed before initial set has occurred and, unless otherwise acceptable to the purchaser, not later than 1½ hours after adding water to the mixture when the air temperature is at 85°F (29°C) or above. This time period

may be extended to a maximum of 2½ hours, provided the purchaser is satisfied that admixtures in sufficient quantity can extend the strength and quality of the concrete. When the air temperature is below 85°F (29°C), the 1½-hour period may be extended by 1 minute for each degree Fahrenheit (2 minutes for each degree Celsius) that the air temperature is below 85°F (29°C). The time for placement shall not exceed a maximum of 2½ hours after the water has first been added to the aggregate–cement mixture unless retarders have been specifically designed and verified by tests to produce the specified properties of the mixture after that point.

Concrete shall not be placed in water, nor shall water be allowed to rise over the freshly placed concrete, until after the concrete has set sufficiently to prevent damage to the concrete mixture or finish.

Concrete shall be deposited in approximately horizontal layers or lifts not to exceed 24 in. (0.6 m) in depth. Before a new lift is placed, the concrete in the previously placed lift shall be thoroughly and systematically vibrated. The vibrator shall penetrate the upper two lifts and shall be slowly removed. Each lift shall be vibrated twice. Vibration does not apply to self-consolidating concrete.

Top surfaces shall be to line and grade and, unless otherwise specified, shall receive a float finish. Interior and exposed exterior wall surfaces shall receive a smooth form finish unless otherwise specified. Exterior surfaces below grade may receive a rough form finish.

Concrete that is honeycombed or that does not meet the requirements of chapter 5 of ACI 350.5 shall be removed to sound concrete and repaired in accordance with chapter 5 of ACI 350.5. An epoxy bonding agent meeting the requirements of Sec. 2.8 shall be used when repairing defective areas.

**5.2.6.3 Flat roofs.** Prior to construction, the constructor shall submit the proposed roof placement details and procedures for review unless those details and procedures are specified in the contract documents. The roof concrete shall be power-float finished, unless otherwise specified.

**5.2.6.4 Dome roofs.** Concrete or shotcrete in dome roofs should be placed in circumferential strips no wider than 8 ft (2.5 m), starting at the outer edge and progressing toward the center. The roof shall be float finished unless otherwise specified. The interior of dome roofs shot against polyurethane foam (ACI 334.3R) may have an as-shot interior finish.

**5.2.7 Seismic cables.** When seismic cables are installed in floor–wall or wall–roof connections of circular tanks to restrain differential tangential motion between the wall and floor or roof, the following precautions shall be taken:

5.2.7.1 Separation sleeves. Sleeves of rubber or other similar material shall surround the strands at the joint to permit radial wall movements. Concrete or grout shall be prevented from entering the sleeves. The remainder of the cable shall bond to the wall concrete and to the footing concrete. Cables may be prebent to assist in their installation in the forms.

5.2.7.2 Placing. Cables should be cut to uniform lengths before being placed in the forms. Care shall be taken during concrete placement to avoid displacement of the isolation sleeves, plastic film, or bearing pads and potential restraint of radial wall movement.

### Sec. 5.3 Precast Concrete

#### 5.3.1 *Formwork.*

5.3.1.1 General. Formwork shall meet the requirements of ACI 347R and ACI 350.5 unless modified by the purchaser in the project specifications. In circular tanks or curved portions of other configurations, the forms shall be curved to the radius required, or straight segments not exceeding 30 in. (750 mm) in length may be used.

5.3.1.2 Joint form ties. Form ties that remain in the wall shall have water-stops and shall be of the “snap-off breakback” type with plastic inserts to form a hole at least 1-in. (25-mm) deep for patching. Through-bolts shall be tapered for ease of removal and patching. After bolts are removed, the bolt holes shall be thoroughly cleaned and patched, as required in Sec. 5.2.1.2.

#### 5.3.2 *Concreting.*

5.3.2.1 General requirements. Measuring, mixing, and transportation shall be in accordance with ACI 350.5; placing should be in accordance with ACI 304R; and curing shall be in accordance with ACI 308R. Other requirements shall be in accordance with Sec. 2.1.1.

5.3.2.2 Precast wall panels. Concrete for precast wall panels shall be placed in one continuous operation, placed as nearly as possible to its final position in the form, and consolidated by using internal or external vibrators. The curved cross section requires that concrete be placed starting at the lower end of the slope and progressing upward, thereby increasing compaction of the concrete.

#### 5.3.3 *Precast wall panel handling, storage, shipping, erection, and joining.*

5.3.3.1 Handling. The location of pickup points for handling and field erection shall be indicated on the shop drawings. Wall panels shall be stored and handled at designated locations only.

5.3.3.2 Storage. Plant and jobsite storage areas shall be suitable to prevent differential twisting or warping of wall panels.

5.3.3.3 Shipping. Wall panels that are not site cast are usually transported on semi-tractor trailer trucks. The precast panels shall be loaded and supported on the transport in a manner that will prevent spalling or cracking.

5.3.3.4 Erection. Wall panels shall be erected to the correct vertical and horizontal alignment within the tolerances set forth in Sec. 5.6.

5.3.3.5 Inserts. Inserts for lifting and bracing wall panels shall be recessed and, after use, shall be patched using a nonshrink grout. The patching material shall be preceded in the recess by an epoxy bonding agent.

5.3.3.6 Vertical joints between precast panels. The vertical joints between panels shall be free of dirt or foreign substances. Concrete surfaces in the joints shall be sandblasted prior to erection and dampened prior to filling. The joints shall be filled with cast-in-place concrete, epoxy, or grout compatible with the details of the joint. The joint fill shall be proportioned, placed, and cured in a manner that will provide at least 20 percent greater strength than required for the structural capacity of the wall panels.

5.3.4 *Nonprestressed steel reinforcement.* Steel reinforcement shall be placed in conformance with ACI 350.5. The minimum cover over prestressed and nonprestressed steel reinforcement, welded-wire fabric reinforcement, and tendon anchorages shall be as set forth in Sec. 3.11.

5.3.5 *Vertical tendons.* Tendons in tank wall panels using post-tensioning tendons shall conform to the requirements of Sec. 5.2.4. Pretensioned tendons for factory-cast wall panels shall conform to ACI 350 and the PCI MNL-116 *Manual*.

5.3.6 *Horizontal tendons.* The following paragraphs cover the application of tendons as horizontal prestressing for concrete tank walls or ring beams. Post-tensioning systems may be individually sheathed and cast in place or placed in ducts cast into wall panels and grouted before prestressing (for unbonded tendons) or after prestressing (for bonded tendons).

5.3.6.1 Field handling and storage. Field handling and storage of prestressing strand shall be such that the strands are fully protected from physical damage and undue corrosion (see Sec. 5.2.4.1) before, during, and after placement. Such protection, particularly for nongalvanized steel, shall include enclosed, ventilated temporary storage facilities where weather conditions warrant. In no event shall materials be allowed to sit in standing water or mud. Corroded strands (see Sec. 5.2.4.1) shall not be installed.

5.3.6.2 *Supervisor.* Installation and field handling of tendons, stressing, and grouting shall be under the direction of a supervisor who has PTI Levels 1 and 2 Unbonded PT Ironworker Certification for tanks with unbonded tendons and PTI Levels 1 and 2 Bonded PT Field Specialist Certification for tanks with bonded tendons. The supervisor shall also have technical knowledge of prestressing principles, and at least five years of experience with the particular system of post-tensioning and equipment being used.

5.3.6.3 *Unbonded tendons.* Unbonded single-strand tendons shall be installed by placers, a minimum of half of whom shall be PTI Level 1 Unbonded PT Ironworker certified, and shall be installed in accordance with the *PTI Field Procedures Manual for Unbonded Single-Strand Tendons*.

5.3.6.4 *Prestressing.* Tendons shall be tensioned in accordance with ACI 350 and Sec. 5.2.4.4.

## **Sec. 5.4 Waterstops and Sealants**

5.4.1 *Placing.* PVC waterstops should be secured by split forms or other means to ensure positive positioning and, for vertical joints, tied to reinforcement at least every 12 in. (300 mm) to prevent displacement during concrete placement.

5.4.2 *Encasement.* Horizontal PVC waterstops in roof and floor slabs should be accessible during the concrete placement. They should be secured in a manner allowing them to be bent up while concrete is placed and compacted underneath, after which they should be allowed to return to position and the additional concrete placed over the waterstop. Care shall be taken to avoid a downward deflection of the waterstop after it has been folded down on the previously placed and compacted concrete.

5.4.3 *Continuity.* Waterstops shall be spliced in a manner to ensure complete continuity as a water barrier and as recommended by the manufacturer.

5.4.4 *Sealants and adhesive waterstops.* Joints with sealants or adhesive waterstops should be constructed to accommodate the calculated movement, if any, in accordance with ACI 504R. Joints should be free of form release agents, loose concrete, moisture, dust, and other contaminants that would inhibit proper bond to the concrete surface. The sealants or adhesive waterstops shall be used in accordance with the manufacturer's recommendations.

## **Sec. 5.5 Elastomeric Bearing Pads and Sponge Fillers**

5.5.1 *Positioning.* Bearing pads and sponge-rubber fillers shall be positively positioned and attached to the concrete with a moisture-insensitive adhesive

to prevent uplift during concreting. Pads in cast-in-place concrete walls shall also be held in position and protected from damage from nonprestressed reinforcement ends by inserting small, dense concrete blocks or plastic shims under the vertical reinforcing steel. Nailing of pads shall not be permitted. The joint shall be detailed and constructed to ensure freedom from obstructions that might prevent free movement of the wall base.

5.5.2 *Sponge-rubber fillers.* Sponge-rubber fillers shall be of sufficient width and correctly placed to prevent voids between the sponge rubber, bearing pads, and waterstops. Fillers shall be detailed and installed to provide complete separation at the joint as required in the design.

5.5.3 *Fillers.* Voids and cavities occurring between butted ends of pads, between pads and waterstops, and between a pad and joint filler shall be filled with nontoxic sealant compatible with the materials of the pad, filler, and waterstop and the concrete surface. No concrete-to-concrete hard spots that would inhibit free translation of the wall shall be permitted.

## Sec. 5.6 Tolerances

5.6.1 *Tolerance measured on inside surface at any height.* The maximum deviation from the specified tank radius or inside dimension shall be  $\pm\frac{1}{2}$  in. per 50 ft ( $\pm 13$  mm per 15 m) of the distance from established center but not exceeding  $\pm 1$  in. ( $\pm 25$  mm). The maximum deviation of the tank radius or wall face along any 10 ft (3 m) of circumference or length shall be  $\pm\frac{3}{8}$  in. ( $\pm 10$  mm) and shall be a smooth curve.

5.6.2 *Plumb.* Walls shall be plumb to the base within a tolerance not exceeding  $\frac{1}{4}$  in. per 10 ft (6 mm per 3 m) of vertical height or  $\frac{3}{4}$  in. (20 mm) total.

5.6.3 *Wall thickness.* The tolerances on the specified wall thickness shall be  $+\frac{3}{8}$  in.,  $-\frac{1}{4}$  in. ( $+10$  mm,  $-6$  mm) for a wall thickness of 12 in. (300 mm) or less and  $+\frac{1}{2}$  in.,  $-\frac{3}{8}$  in. ( $+13$  mm,  $-10$  mm) for a wall thickness greater than 12 in. (300 mm).

### 5.6.4 *Precast panels.*

5.6.4.1 *Alignment tolerance.* Misalignment between the centroids of adjoining precast concrete panels shall not exceed  $\frac{3}{16}$  in. (5 mm).

5.6.4.2 *Fabrication tolerance.* Fabricated wall panels shall have the following tolerances unless otherwise specified:

Length	$\pm\frac{1}{2}$ in. ( $\pm 13$ mm)
--------	-------------------------------------

Width	$\pm\frac{1}{2}$ in. ( $\pm 13$ mm)
Thickness	$+\frac{1}{4}$ in., $-\frac{1}{8}$ in. (+6 mm, -3 mm)
Warping	$\frac{3}{8}$ in. (10 mm)
Tendon and duct location	$\pm\frac{1}{8}$ in. ( $\pm 3$ mm) within the thickness of the wall, $\pm\frac{1}{2}$ in. ( $\pm 13$ mm) vertically
End squareness	$\frac{1}{4}$ in. (6 mm)

5.6.5 *Waterstop and bearing-pad alignment.* Waterstop and bearing pads shall be aligned within  $\pm\frac{1}{4}$  in. ( $\pm 6$  mm) of their design location, measured from the inside face of the wall.

5.6.6 *Other.* Other tolerances shall be in accordance with ACI 350.

## Sec. 5.7 Cleaning and Disinfection

5.7.1 *Cleaning.* After the tank has been completed, the interior of the tank shall be carefully cleaned out. Rubbish, trash, loose material, and other items of a temporary nature shall be removed from the tank. Then, the tank shall be thoroughly cleaned with a high-pressure water jet, sweeping, scrubbing, or other effective means. Water and dirt or foreign material accumulated in this cleaning operation shall be discharged from the tank or otherwise removed. Interior surfaces of the tank shall be kept clean until final acceptance. Any cracks in water-retaining concrete that are revealed shall be sealed by epoxy injection or other approved means, in accordance with the provisions of Sec. 6.3.

5.7.2 *Screens.* Following the cleaning operation, the vent screen, overflow screen, and any other screened openings shall be checked and put in satisfactory condition to prevent birds, rodents, insects, and other possible contaminants from entering the tank.

5.7.3 *Disinfection.* Potable water tanks shall be disinfected in accordance with ANSI/AWWA C652 or local regulations.

## Sec. 5.8 Backfill

When wall backfill is required, it shall be initiated only after the tank has been satisfactorily filled and tested. Backfill material shall be placed in uniform layers and compacted as specified by the purchaser. Unbalanced backfill placement (on one side of the tank) shall be avoided, except as may be fully provided for in the design. The tank shall remain full during backfill operations.

## Sec. 5.9 Electrical Grounding

Electrical grounding to the reinforcing steel or prestressed tendons for any equipment or electrical service shall be strictly prohibited.

---

## SECTION 6: WATERTIGHTNESS

---

### Sec. 6.1 General

As previously discussed, properly designed, constructed, and crack-free concrete is, for all intents and purposes, impermeable to water. With a permeability of  $5 \times 10^{-14}$  m/sec (for cement paste with a water/cement ratio of 0.45), the loss through the wall of a 5-mil gal tank would be less than 0.00001 percent per 72 hours. Many tanks have been constructed and found to have no measurable leakage when tested for watertightness. Loss of water can occur, however, because of lower-grade workmanship at honeycombed, cracked, or other defective areas in the floors or walls or through leaks in the piping and valves. The watertightness for each of these elements is discussed in the following sections.

6.1.1 *Walls.* Seepage that produces moisture on the wall that can be picked up on a dry hand (wet spots) shall not be accepted. Moisture-darkened spots where moisture cannot be picked up on a dry hand (damp spots) are acceptable because the permeability normally will decrease with time.

6.1.2 *Wall-floor joint.* Visible flow of water through the wall-floor joint on top of the exterior wall footing shall not be accepted. Dampness or wetness on top of the footing that cannot be observed to be flowing water is acceptable. In total, the wall and wall-floor joint shall have no measurable seepage and shall be watertight.

6.1.3 *Floors, piping, and valves.* Generally, loss of water through the tank floor, piping, and valves cannot be determined separately. Loss of water through the floors, piping, and valves shall not exceed the criteria set forth in the following section. If the loss of water exceeds the criteria, the tank floor shall be inspected for point sources of leakage with the tank full or empty. Any potential point sources of leakage found shall be repaired and the watertightness test repeated. To ensure no piping or valve leakage, install blind flanges or plugs in pipelines.

6.1.4 *Watertightness criteria.* The criteria for watertightness depend on the type of floor used in the tank. Because walls and wall-floor joints are required to be watertight, the acceptance criteria relate only to the watertightness of the floor, piping, and valves. Therefore, for tanks with monolithically placed post-tensioned floors, the unexplained loss of water shall be 0.0125 percent or less per 24 hours. For all other floor types, the water loss shall be 0.05 percent or less in 24 hours.



If special conditions exist, more stringent requirements than the above may be specified. Special conditions include soils subject to piping action or swelling with increases in moisture content, and cases where the value of the contents justifies greater watertightness.

Visible flow of water from beneath the tank is not acceptable unless it is known to be groundwater, which is collected in underdrain systems specifically designed for this purpose. Furthermore, floors, walls, and wall–floor joints shall not allow groundwater to flow into potable water tanks.

## Sec. 6.2 Testing

6.2.1 *Watertightness.* Watertightness testing shall be completed prior to any specified backfill placement over the footing or adjacent to the wall to facilitate observation of criteria for wall and wall–floor joint.

6.2.2 *Preparation.* The tank should be filled with water to the overflow level. Measurement shall not be initiated until a minimum of 24 hours after the tank is filled.

6.2.3 *Measurement.* The drop in liquid level should be measured over at least the time period given for the selected criteria to determine the volume loss. The length of the measurement period should also be established so as to provide for a drop in liquid level of at least  $\frac{3}{8}$  in. (10 mm) at the maximum permissible rate. Evaporative losses or precipitation gains (in open-top tanks) may be measured or calculated and deducted from the water loss to determine compliance with the acceptance criteria. Similarly, moisture expansion of walls can also be calculated as it also will lower the water level. (The majority of moisture expansion of an air-dried concrete wall will occur within 14 days after the tank is filled with water.)

If the loss of water exceeds the above criteria, the test may be repeated or extended for additional time periods. If, at the end of the additional time period(s), the average drop in water level falls within the above criteria, the loss is acceptable. If not, the tank shall be repaired, disinfected again, if applicable, and retested until the drop in liquid level falls within the chosen criteria.

ACI 350.1 gives additional information on testing of tanks for watertightness.

## Sec. 6.3 Repairs

The constructor shall make necessary repairs if the tank fails the watertightness test or is otherwise defective. The purchaser shall review the method of repair. The most common repair method for honeycombed concrete (rock pockets) and other defective concrete is removal and replacement with nonshrink grout (which

may include pea gravel aggregate) bonded to the concrete with epoxy bonding agents. The minimum strength of the grout shall equal or exceed the specified strength of the concrete.

6.3.1 *Chemical or epoxy injection grouting system.* Seeps in prestressed concrete shall be repaired with a high-pressure epoxy injection grouting system or other system acceptable to the engineer. Seeps in nonprestressed concrete shall be repaired with an epoxy or chemical grouting system or other system acceptable to the engineer. If epoxy grouting is performed, a low-viscosity, moisture-insensitive two-component epoxy system with an in-line metering and mixing system shall be used. Pumps shall be capable of producing a minimum injection pressure of 100 psi (680 Pa). Injection pressures shall be limited to 300 psi (2.1 MPa) to ensure complete penetration of the defective voids without damaging the structure. Epoxy shall reach a minimum compressive strength of 6,000 psi (40 MPa) in 24 hours, in accordance with the requirements of ASTM D695. A factory-trained, authorized applicator with successful past experience in repair of water-retaining structures shall be present on the job at all times while repairs are being made.

Any exposed defect receiving epoxy shall first be cleaned of dirt, laitance, and other material that might prevent proper bonding. A suitable temporary seal shall be applied to the surface or surfaces of a repairable crack or honeycombed area to prevent escape of the epoxy. Entry ports shall be spaced along the seal at intervals not greater than the thickness of the element. The epoxy shall be injected into the lowest port first, with sufficient pressure to advance the epoxy to an adjacent port, using a small nozzle held tightly against the port. The operation shall continue until epoxy material begins to extrude from the adjacent port. The previous port shall be sealed and the injection shall proceed at the adjacent port. This shall be repeated in one continuous operation until the crack or honeycombed area has been completely injected with epoxy. Ports, including adjacent locations where epoxy seepage occurs, shall be sealed as necessary to prevent drips and runouts.

On completion of the injection, the grout shall be allowed to cure for sufficient time to allow removal of the temporary seal without any drainage or epoxy material running out of the crack. On tank surfaces exposed to view, the surface of the concrete shall be finished flush with the adjacent surfaces and shall show no indentations or evidence of port filling.

6.3.2 *Epoxy or elastomeric coating.* Seeps in walls, floors, and roof slabs may also be repaired by coatings. If epoxy coating is performed, a nonsag-viscosity, moisture-insensitive, low-modulus two-component epoxy system shall be used. Epoxy

shall reach a minimum compressive strength of 6,000 psi (40 MPa) in 24 hours, in accordance with the requirements of ASTM D695. Any exposed defect receiving an epoxy coating shall first be cleaned of dirt, laitance, and other material that might prevent proper bonding. Cleaning shall be in accordance with ASTM D4258, and abrading shall be in accordance with ASTM D4259.

The epoxy coating shall be applied to the inside face and, if needed, to the outside face of the wall over an area of at least 1 ft (300 mm) in each direction from the edges of the seepage area. The minimum thickness of the epoxy coating shall be 1/8 in. (3 mm). If the exterior coating is to be visible after completion of the tank, it shall be properly finished.

---

## **SECTION 7: OBSERVATIONS**

---

It is recommended that the purchaser perform observations during construction, after construction, and during routine maintenance. See appendix B for a more complete description of recommended observation procedures.

---

## **SECTION 8: AFFIDAVIT OF COMPLIANCE**

---

The purchaser may require an affidavit from the manufacturer that the material provided complies with applicable requirements of this standard.

This page intentionally blank.

# APPENDIX A

## Bibliography

*This appendix is for information only and is not a part of ANSI/AWWA D115.*

1. ANSI/AWWA D110-13. 2013. Wire- and Strand-Wound, Circular, Prestressed Concrete Water Tanks. Denver, CO: American Water Works Association.
2. Baker, E.H., L. Kovalevsky, and F.L. Rish. 1972. *Structural Analysis of Shells*. New York: McGraw-Hill Book Company.
3. Portland Cement Association. 1993. *Circular Concrete Tanks Without Prestressing*, tables of coefficients starting on p. 29. Skokie, IL: Portland Cement Association.
4. American Concrete Institute. 1988. ACI 344R-T. *Design and Construction of Circular Prestressed Concrete Structures with Circumferential Tendons*. Detroit, MI: American Concrete Institute.
5. Ghali, A. 2014. *Circular Storage Tanks and Silos*, 3rd ed. Boca Raton, FL: CRC Press.
6. Housner, G.W. 1954. *Earthquake Pressures on Fluid Containers*. Pasadena, CA: California Institute of Technology.
7. Housner, G.W. 1957. Dynamic Pressures on Accelerated Fluid Containers. *Bull. Seismol. Soc. Amer.*, 47(1):15.
8. Housner, G.W. 1956. Limit Design of Structures to Resist Earthquakes. In *Proc. World Conf. on Earthquake Engineering*. Berkeley, CA.
9. Jacobsen, L.S. 1949. Impulsive Hydrodynamics of Fluid Inside a Cylindrical Tank and of a Fluid Surrounding a Cylindrical Pier. *Bull. Seismol. Soc. Amer.*, 39:189.
10. Lockheed Aircraft Corporation, Homes & Narver, and US Atomic Energy Commission. 1963. *Nuclear Reactors and Earthquakes*, chapter 6 and appendix F. US Nuclear Regulatory Commission (formerly US Atomic Energy Commission) publication, Division of Technical Information, TID7024, National Technical Information Service. Oakridge, TN: US Atomic Energy Commission.
11. ANSI/AWWA D100-11. 2011. Welded Carbon Steel Tanks for Water Storage. Denver, CO: American Water Works Association.
12. Timoshenko, S., and S. Woinowsky-Krieger. 2015 (reprint). *Theory of Plates and Shells*, 2nd ed. New York: McGraw-Hill Book Company.

13. Zarghamee, M.S., and F.J. Heger. 1983. Buckling of Thin Concrete Domes. *ACI Journal Proceedings*, 80(6):487-500.

14. Neville, A.M. 2012. *Properties of Concrete*, 5th ed. Harlow, Eng.: Pearson.

# APPENDIX B

## Observation Procedures

*This appendix is for information only and is not a part of ANSI/AWWA D115.*

---

### SECTION B.1: SCOPE

---

This section provides procedures for observations of tendon-prestressed concrete tanks during construction, after construction, and during routine maintenance. The latest governing editions of ACI SP2 and the appropriate requirements of ACI 350 and ACI 350.5 should be followed, except as modified by this standard. Suggestions for maintenance repairs are also included in this section.

---

### SECTION B.2: OBSERVATIONS DURING CONSTRUCTION

---

#### **Sec. B.2.1 General**

The purpose of observations during construction is to assist the constructor in interpretation of the plans and specifications. The observer can also assist in seeing that acceptable construction procedures are followed. The goal is to ensure that the completed tank is constructed in accordance with the plans and specifications and in accordance with this standard, is structurally sound, has adequate protection (cover) for the conventional reinforcement and prestressing, and is watertight within the specified criteria. The construction procedures given in Section 5 are for the guidance of both the constructor and the purchaser's agent. This section provides additional guidance for observations of those phases of construction requiring the greatest care to ensure a well-constructed tank. Accurate and detailed records of all phases of construction should be kept and maintained for future reference.

#### **Sec. B.2.2 Observations of Cast-in-Place Concrete Construction**

Close observations of the following items are essential because of the items' importance to the corrosion resistance and structural integrity of the tank.

When earth is used as part of the footing or slab form, loose material, clods, or roots that might be dislodged during concrete placement or could permit

settlement or impair concrete cover of reinforcement should be removed. Earth should not be used as a vertical form for any part of the structure. Reinforcing steel should be checked immediately prior to concrete placement to verify that the steel is properly positioned, adequately supported, and will have the specified concrete cover. If nonmetallic spacers (e.g., concrete “dobies”) are used between reinforcing bars and forms, it should be verified that they are of adequate size, density, and number and are of low permeability. No one should be allowed to walk on the reinforcing steel during the placement of concrete unless the supports and ties are designed for that purpose.

It should be verified that form ties that are to remain in the tank wall have waterstops and are used with specified inserts so that the ties can be clipped or snapped off well below the concrete surface. As soon as possible after the forms are removed, the tie holes on the interior wall surface should be packed with nonshrink or epoxy mortar-grout. The holes on the exterior of walls should be dry-packed with portland cement or nonmetallic, nonshrink grout. If through-bolts are used, the holes should be cleaned by sandblasting or wire brushing to remove grease, bond breaker, or laitance. Holes should be vinyl plugged and patched with nonshrink or epoxy mortar-grout in accordance with acceptable details. The outer 1 in. (25 mm) of the hole should be patched with portland cement grout.

Waterstop installations should be checked prior to concrete placement to verify that they are properly located in the joints, adequately secured, and fully fused together at the joints as specified. Horizontal PVC-type waterstops should be accessible during concrete placement. The free edges of the waterstops should be lifted and the concrete placed and compacted underneath before any placement of concrete over the waterstops. The upper free edge of the waterstop in a floor-to-wall joint should be adequately laterally supported as required to prevent displacement during the initial wall concrete placement (see Sec. 5.2.6.2). It is extremely important that waterstops are fully embedded in the concrete and that no voids remain.

If elastomeric pads and sponge fillers are used between the tank wall and floor or footing ring, or between the dome or slab roof and tank wall, it should be verified that the pads and fillers are properly positioned and secured before concrete is placed. After placement, it should be verified that the wall joint is free of any obstructions that would interfere with free movement (see also Sec. 5.6).

**B.2.2.1 Observations of tendons.** Ducts for grouted internal tendons should be securely fastened to prevent distortion, movement, or damage from placement and vibration of the concrete. The ends of the ducts should be covered and splices



sealed as required to prevent the entry of mortar, water, or other debris. The ducts should be observed prior to the concrete placement to help prevent mortar leakage or indentations that would restrict movement of the prestressed reinforcement during the placing or stressing operation. Drains should be provided at intentional low spots in the ducts during periods subject to freezing. Vents should be provided at intentional high spots to help avoid air pockets. Ducts with preplaced strands should be checked prior to grouting to ensure that no blockages exist.

Unbonded monostrand tendons should be tied to supports as necessary to control wobble (see Sec. 5.2.4.3). Care should be taken to prevent tears in sheathing. Tears and surface nicks should be repaired by waterproof methods. Installation should be in accordance with PTI *Field Procedures Manual for Unbonded Single Strand Tendons*.

It should be ensured that the vertical tendons, if any, are tensioned prior to circumferential prestressing, but not until the wall attains its specified strength.

In circular tanks, the circumferential tendons should be tensioned in a sequence that will be as symmetrical as practical about the tank's axis. This generally involves alternating sides of the buttress as tensioning proceeds and alternating buttresses to achieve symmetry. The prestressing sequence, as required by the design and the tendon forces and elongations calculated by the post-tensioning supplier, should be detailed on the shop drawings.

The grouting of grouted tendons should be carried out as soon as possible after the tendons have been stressed and elongations and forces have been checked. Exposure of the prestressing steel to other than a controlled environment prior to grouting should be limited (see Sec. 5.2.4.5).

The vents and drains at high and low points, including a vent at the opposite end of the tendon from the point of grout injection, should be closed when a steady stream of pure grout is ejecting. Grout injection for vertical tendons should be from the lowest point in the tendon to avoid entrapping air. If standpipes are used, they should be removed after the grout has set.

When quick setting of grout can occur as a result of hot-weather operations, the grout should be cooled by acceptable methods, such as using ice chips in the mixing water.

During periods of freezing weather, adequate means should be provided to protect the grout from freezing during and following its placement until the grout reaches its specified minimum strength.

### **Sec. B.2.3 Observations of Precast Panels**

The fabrication of the precast panels should be observed. The quality of the form and its trueness should be checked prior to the start of panel fabrication. Placement of the reinforcing, ducts, and tendons should be checked for accuracy. Test cylinders should be taken and the results should be recorded for future reference. A set of cylinders should be broken before erection of the panels (or shipment, if plant cast) or at 28 days, whichever is earlier, to ensure the concrete has achieved its design strength.

All plant-cast precast panels should be identified with the following markings stenciled onto the top edge of the panel: (1) name of manufacturer, (2) date of fabrication, (3) project name, and (4) tank size.

Precast panels should be checked for damage that may have occurred during shipping and handling. Spalling or defects should be patched using shrinkage-compensating cement grout. The ducts that are cast into the panels should be checked for foreign matter or water. Ducts are to be cleared of any such items. For ducts intended to be grouted after placement of the filler between precast panels, check that the ducts are sealed in a watertight manner between panels.

It should be verified that the edges of precast panels are in alignment as specified. Check that vertical slots between precast panels are cleaned and filled with fine aggregate concrete or as specified.

It should be verified that voids, honeycombed concrete, and other defects in all walls are completely cut out to solid concrete and dry-packed.

---

## **SECTION B.3: OBSERVATIONS AFTER CONSTRUCTION**

---

### **Sec. B.3.1 General**

The test should be observed to determine the watertightness of the tank and to verify that the work has been satisfactorily completed and appurtenances installed in accordance with the plans and specifications.

### **Sec. B.3.2 Watertightness**

Testing should be in accordance with Sec. 6.2. The weather must be dry in order to observe the tests. Particular attention should be given to the ground surface around the tank, as well as at the perimeter drains if used, for evidence of leakage at the floor or floor-wall connection or around piping. To verify the source

of water from a suspected leak, it may be helpful to check for chlorine or to use a nontoxic dye inside the tank.

Using a knowledgeable diver with underwater lights will often be the most efficient way to locate leaks. Sometimes a diver can locate a leak by placing a waterproof membrane or sterile cotton ball over a suspicious crack or rock pocket. For tanks that are to remain in service, a diver with a clean wetsuit should be employed in order to protect treated water from contamination. It is also recommended that the diver be equipped for underwater photography or have underwater note-writing material to detect, locate, and reference cracks that open only under hydrostatic loading. Personnel should never be permitted to enter a tank for underwater observations without carefully observing safety procedures, such as guarding or closing the valves at outlets, providing suitable lighting, and other appropriate protective measures. See also Sec. B.4.1. The interior source of leaks through floors can often be located by use of a vacuum box and soap solution after the tank is emptied.

### **Sec. B.3.3 Walls**

The exterior wall should be carefully observed for any evidence of areas where water can be picked up on a dry hand. The interior source of leaks through walls, either from cracks, honeycombing, or ties, can often be located by use of a vacuum box and soap solution after the tank is emptied.

### **Sec. B.3.4 Repairs**

Repairs should be made in accordance with Sec. 6.3. Repair work should be observed while in progress and on completion. Repair work should be properly cured.

### **Sec. B.3.5 Disinfection**

Potable water tanks should be disinfected prior to watertightness being checked. Disinfection should be in accordance with Sec. 5.7 unless more rigid standards are mandated by state or local regulatory authorities or by the purchaser.

---

## **SECTION B.4: OBSERVATIONS DURING ROUTINE MAINTENANCE**

---

Tanks should be examined after the first year of service or at any time there are visible or suspected problems. It is extremely rare for internal tendon tanks in service for a year or more to suddenly develop problems; however, it is always prudent to document examination from time to time. Preferably, exterior examinations

of aboveground portions of tanks should be conducted routinely every five years during a time when any exposed tank surfaces are dry and groundwater is at a minimum.

Interior examinations and retesting for watertightness should be done whenever the tank is taken out of service for cleaning or other reasons. The tank should be isolated from the system without valve leakage. Watertightness should be verified by measuring a drop in the water surface over a suitable time period in accordance with Sec. 6.2. Observations should also include the following criteria:

#### **Sec. B.4.1 Floor and Footing**

For aboveground tanks, a visual examination of the ground surface around the tank may reveal any leakage through the floor, at the floor–wall connection, or at piping. If a subdrain system has been installed under the floor, water flowing from the system can be checked for chlorine or other chemicals, such as fluoride, and for flow rate. This is particularly important for buried tanks to determine whether the water is finished potable water or groundwater. When the tank is full and new leakage is suspected, possible leakage from cracks or joints in the floor or from the floor–wall connection of a buried or partially backfilled tank may be detected from inside the tank by divers. The divers can sometimes locate these cracks by the evidence of silt buildup at small cracks or by the observation of clean lines at the larger cracks. The divers could further release an indicator, such as a USEPA- or NSF-approved dye or a sterile white cotton ball, at a suspected leak. The indicator verifies the leak if it moves toward the crack or if it appears outside the tank. Also, leaks may be found in buried tanks in high groundwater tables when the tank is drained and observations are made from the inside. Care, however, should be taken not to overstress the floor from the underside. Locations of these leaks found from the inside should be well documented based on measurement from a fixed reference point, such as the access hatch, from both the interior and exterior. Leaks should be repaired. See also Sec. B.3.2.

#### **Sec. B.4.2 Wall**

If not backfilled, the exterior surface of the wall should be physically examined to locate signs of possible deterioration or corrosion, including rust stains, efflorescence, cracks, or seepage. Binoculars are helpful in examining those portions of the wall not readily accessible by a ladder or scaffolding. The location and severity of the preceding signs of possible trouble should be carefully recorded for comparison to future observations if repairs are not warranted at the time. Color

photographs are valuable additions to accompany the written record. Leaks should be repaired as described in Sec. 6.3.

If the examination shows corrosion, cracking, deterioration of the concrete, or evidence of leakage on the exterior of the wall, these areas should be reviewed by a professional engineer with expertise in this field, and the engineer should recommend whether or not additional remedial work is needed.

### **Sec. B.4.3 Roof**

Both the interior and the exterior of the roof should be physically examined for any sign of rust, efflorescence, cracks, or spalling. Monitors, sample ports, man-holes, or other roof penetrations should be observed for rust, cracks, or leakage. Spalled areas and cracks where leakage through the roof may occur should be repaired. If leakage is evident, a suitable nontoxic roof sealant should be applied to protect the reinforcing steel and to maintain water quality. Sealants at joints in flat slab roofs should be carefully observed. If joint leakage or disbonded sealant is observed, the sealant should be removed and replaced.

This page intentionally blank.

## APPENDIX C

### Additional Design Considerations

*This appendix is for information only and is not a part of ANSI/AWWA D115.*

This appendix provides additional information on design options for tendon-prestressed concrete tanks that may be useful to purchasers and/or their design consultants.

---

#### SECTION C.1: ROOF OPENINGS

---

Double roof hatches may be desirable for increased security and another barrier for dust, dirt, insects, birds, and rodents. The area between the inner and outer hatch structures provides convenient space for electrical and instrumentation conduits, enclosures, and hatch limit switches. This area can also be used for staging and decontamination when tank access is necessary.

---

#### SECTION C.2: LADDERS AND STAIRS

---

Interior stairs may be more convenient and potentially safer for access, especially when carrying small tools, hoses, spray equipment, and materials for routine maintenance tasks.

---

#### SECTION C.3: FLOORS

---

After placement, floors should be kept as clean and stain-free as practicable during the remainder of wall and roof construction. Grease, oil, tire marks, and rust or other stains on the floor may not be acceptable in potable water structures and should be prevented. Preventive measures may include installing equipment “diapers” and tire “socks,” lining equipment travel lanes with plywood pads, placing protective padding under scaffolding bases, using containment pans to catch potential spills, and similar measures. Note that many deleterious substances can penetrate the concrete surface over time, making them difficult or impossible to remove completely.

---

## **SECTION C.4: SPONGE-RUBBER FILLERS**

---

Fillers that will be in contact with potable water when the tank is in service should be removed before construction is complete if there is a concern about bacteria growth.



This page intentionally blank.

This page intentionally blank.

This page intentionally blank.



## American Water Works Association

6666 West Quincy Avenue  
Denver, CO 80235-3098  
T 800.926.7337  
[www.awwa.org](http://www.awwa.org)

*Dedicated to the world's most important resource, AWWA sets the standard for water knowledge, management, and informed public policy. AWWA members provide solutions to improve public health, protect the environment, strengthen the economy, and enhance our quality of life.*



1P-2M 44115-2017 (7/17) IW

Printed on Recycled Paper

